

DOE/NETL CARBON CAPTURE PROGRAM R&D COMPENDIUM of CARBON CAPTURE TECHNOLOGY

JULY 2015



U.S. DEPARTMENT OF
ENERGY



Cover image: Post-Combustion Test Facility at the National Carbon Capture Center, Wilsonville, Alabama, USA.
Image provided by Southern Company Services.

DISCLAIMER

This report was prepared as an account of work sponsored by an agency of the United States Government. Neither the United States Government nor any agency thereof, nor any of their employees, makes any warranty, express or implied, or assumes any legal liability or responsibility for the accuracy, completeness, or usefulness of any information, apparatus, product, or process disclosed, or represents that its use would not infringe privately owned rights. Reference herein to any specific commercial product, process, or service by trade name, trademark, manufacturer, or otherwise does not necessarily constitute or imply its endorsement, recommendation, or favoring by the United States Government or any agency thereof. The views and opinions of authors expressed herein do not necessarily state or reflect those of the United States Government or any agency thereof.

TABLE OF CONTENTS

OVERVIEW

POST-COMBUSTION SOLVENT TECHNOLOGIES

GE Global Research – Phase-Changing Absorbent	13
Center for Applied Energy Research, University of Kentucky – Hybrid Membrane/Advanced Catalyst Solvent	18
Akermin, Inc. – Carbonic Anhydrase Catalyzed Advanced Carbonate and Non-Volatile Salt Solution	25
University of Kentucky – Slipstream Demonstration Using the MHPSA Advanced Solvent	31
Linde – Slipstream Novel Amine-Based Post-Combustion Process	37
Pacific Northwest National Laboratory – CO ₂ -Binding Organic Liquid Solvents	42
Southern Company Services – Waste Heat Integration	48
ION Engineering, LLC – Amine Solvent in Ionic Liquid	51
SRI International – Ammonia- and Potassium Carbonate-Based Mixed-Salt Solvent	54
RTI International – Nonaqueous Solvent	59
GE Global Research – Novel Aminosilicone Solvent	63
William Marsh Rice University – Novel Absorption/Stripper Process	69
URS Group – Piperazine Solvent with Flash Regeneration	72
Novozymes – Enzyme and Vacuum Combination Technology	78
Carbon Capture Scientific – Gas-Pressurized Stripping	84
Neumann Systems Group – Carbon Absorber Retrofit Equipment	89
Babcock & Wilcox – Optimized Solvent Formulation	96
University of Illinois at Urbana-Champaign – Hot Carbonate Absorption with Crystallization-Enabled High-Pressure Stripping	99
Lawrence Berkeley National Laboratory – Chemical Additives for CO ₂ Capture	105
3H Company – CO ₂ Capture with Self-Concentrating Amine Absorbent	110
University of Notre Dame – Ionic Liquids	113
Illinois State Geological Survey – Novel Integrated Vacuum Carbonate Process	120
Siemens Energy – POSTCAP Capture and Separation	126
Georgia Tech Research Corporation – Reversible Ionic Liquids	129
Hampton University – Phase Transitional Absorption	134

POST-COMBUSTION SORBENT TECHNOLOGIES

SRI International – Novel Solid Sorbent	139
TDA Research, Inc. – Alkalized Alumina Solid Sorbent	145
Aspen Aerogels, Inc. – Advanced Aerogel Sorbents	150
WR Grace – Rapid Pressure Swing Adsorption	156
RTI International – Advanced Solid Sorbents and Processes for CO ₂ Capture	164
TDA Research, Inc. – Low-Cost, High-Capacity Regenerable Sorbent	169
ADA-ES – Solid Sorbents as Retrofit Technology	175
ADA-ES – Cross-Heat Exchanger for Sorbent-Based CO ₂ Capture	185
InnoSeptra, LLC – Novel Adsorption Process	192
Georgia Institute of Technology – Rapid Temperature Swing Adsorption	197
University of North Dakota – Solid Sorbent-Based CO ₂ Capture	205
University of Akron – Metal Monolithic Amine-Grafted Zeolites	209
UOP – CO ₂ Removal from Flue Gas Using Microporous MOFs	214
RTI International – A Dry Sorbent-Based Post Combustion CO ₂ Capture	220

POST-COMBUSTION MEMBRANE TECHNOLOGIES

Gas Technology Institute – Hollow-Fiber-Membrane Contactor with aMDEA Solvent	225
Membrane Technology and Research, Inc. – Hybrid Membrane, Amine Absorption	231
Orbital ATK, Inc. – Supersonic Inertial CO ₂ Extraction System	238
American Air Liquide, Inc. – Subambient Temperature Membrane	241
Ohio State University – Inorganic/Polymer Composite Membrane	247
Membrane Technology and Research, Inc. – Polymeric Membranes	252
FuelCell Energy, Inc. – Electrochemical Membrane	259
General Electric Global Research Center – Composite Hollow Fiber Membranes	265
Membrane Technology and Research, Inc. – Low-Pressure Membrane Contactors (Mega-Module)	270
Research Triangle Institute – Hollow-Fiber, Polymeric Membrane	274
Carbozyme – Biomimetic Membrane	280
University of New Mexico – Dual Functional, Silica-Based Membrane	284

PRE-COMBUSTION SOLVENT TECHNOLOGIES	288
SRI International – CO ₂ Capture Using AC-ABC Process	289
PRE-COMBUSTION SORBENT TECHNOLOGIES	295
TDA Research, Inc. – High Capacity Regenerable Sorbent	296
URS Group, Inc. – Sorbent Development for WGS	301
PRE-COMBUSTION MEMBRANE TECHNOLOGIES	307
SRI International – PBI Polymer Membrane	308
Media and Process Technology, Inc. – Two-Stage Membrane Separation: Carbon Molecular Sieve Membrane Reactor followed by Pd-Based Membrane	315
Los Alamos National Laboratory – High-Temperature Polymer-Based Membrane	318
Arizona State University – Dual-Phase Ceramic-Carbonate Membrane Reactor	324
Pall Corporation – Pd-Alloys for Sulfur/Carbon Resistance	329
University of Minnesota – Hydrogen-Selective Zeolite Membranes	334
New Jersey Institute of Technology – Pressure Swing Membrane Absorption Device and Process	338
Gas Technology Institute – Nanoporous, Superhydrophobic Membrane Contactor Process	344
Membrane Technology and Research, Inc. – Polymer Membrane Process Development	348
ADVANCED COMPRESSION TECHNOLOGIES	354
Ramgen Power Systems – Shock Wave Compression	355
Southwest Research Institute – Evaluation of Compression Efficiency Improvements	360
R&D COLLABORATIONS	368
University of North Dakota Energy and Environmental Research Center – Partnership for CO ₂ Capture	369
Argonne National Laboratory – Analysis of CCS Technology Adoption	373
NETL–RESEARCH AND INNOVATION CENTER TECHNOLOGIES	376
National Energy Technology Laboratory—Research and Innovation Center Technologies – Pre- and Post-Combustion Liquid Solvents	377
National Energy Technology Laboratory—Research and Innovation Center Technologies – Pre- and Post-Combustion Solid Sorbent Materials	380
National Energy Technology Laboratory—Research and Innovation Center Technologies – Pre- and Post-Combustion Membrane Materials	383
National Energy Technology Laboratory—Research and Innovation Center Technologies – High-Throughput Computational Tools	386
National Energy Technology Laboratory—Research and Innovation Center Technologies – Carbon Capture Simulation for Industry Impact	388

OVERVIEW

6

The U.S. Department of Energy's (DOE) Fossil Energy program has adopted a comprehensive, multi-pronged approach to the research and development (R&D) of advanced carbon dioxide (CO₂) capture technologies for coal-based power plants. The National Energy Technology Laboratory (NETL) is implementing the Carbon Capture R&D program to develop the next generation of advanced CO₂ capture concepts. Current efforts cover not only improvements to state-of-the-art, first-generation technologies, but also the development of second-generation and transformational advanced CO₂ capture technologies. The success of this research will enable cost-effective implementation of carbon capture and storage (CCS) technologies throughout the power-generation sector and ensure the United States will continue to have access to safe, reliable, and affordable energy from fossil fuels.

DOE's CCS R&D effort is conducted as part of the CCS and Power Systems program under the overarching Clean Coal and Carbon Management Research Program (CCMRP). The CCMRP is administered by the DOE Office of Clean Coal and implemented by NETL through contracted research activities and onsite research at NETL. Research projects are carried out under various award mechanisms—including partnerships, cooperative agreements, and financial assistance grants—with corporations, small businesses, universities, nonprofit organizations, and other national laboratories and Government agencies.

The Carbon Capture program consists of two core research areas, Post-Combustion Capture and Pre-Combustion Capture, composed of approximately 60 projects of technology readiness levels (TRL) ranging from conceptual engineering and materials design (i.e., TRL 2) to 25 megawatt-electrical equivalent pilot testing (i.e., TRL 5–7). These two core areas are focused on creating technological improvements providing a step-change in both cost and performance as compared to current state-of-the-art solvent-based capture systems.

Post-combustion systems separate CO₂ from the flue gas stream produced by conventional pulverized coal power plants after fuel combustion in air. In this approach, CO₂ is separated from nitrogen, the primary constituent of the flue gas. Pre-combustion systems are designed to separate CO₂ from hydrogen and other constituents in the syngas stream produced by the gasifier in integrated gasification combined cycle (IGCC) power plants. In both cases, R&D is underway to develop solvent-, sorbent-, and membrane-based capture technologies. In-depth descriptions of these capture technologies can be found in the Carbon Capture Program Plan: <http://www.netl.doe.gov/technologies/coalpower/ewr/pubs/Program-Plan-Carbon-Capture-2013.pdf>.

This Technology Compendium provides a technical summary of DOE/NETL's Carbon Capture program, assembling CO₂ capture technology R&D descriptions in a single document. The R&D efforts include the development of advanced solvents, sorbents, and membranes for both post- and pre-combustion systems, as well as advanced CO₂ compression technologies and R&D collaborations. The following tables list the CO₂ capture technologies summarized in this compendium, as developed under DOE/NETL external R&D projects.

POST-COMBUSTION SOLVENT TECHNOLOGIES

Although high levels of CO₂ capture are possible with chemical solvent-based systems, these systems also require significant amounts of energy for regeneration, which involves a temperature swing to break the absorbent-CO₂ chemical bond. Advanced solvents that have a lower regeneration energy requirement than commercially-available amine systems, and that are also resistant to flue gas impurities, are being developed through DOE/NETL-sponsored research.

Project Focus	Participant	Performance Period
ACTIVE		
Phase-Changing Absorbent	GE Global Research	1/1/2014 – 12/31/2016
Hybrid Membrane/Advanced Catalyst Solvent	Center for Applied Energy Research, University of Kentucky	10/1/2013 – 12/31/2016
Carbonic Anhydrase Catalyzed Advanced Carbonate and Non-Volatile Salt Solution	Akermin, Inc.	10/1/2010 – 9/30/2016
Slipstream Demonstration Using the MHPSA Advanced Solvent	University of Kentucky	10/1/2011 – 9/30/2016
Slipstream Novel Amine-Based Post-Combustion Process	Linde	12/1/2011 – 8/31/2016
CO ₂ -Binding Organic Liquid Solvents	Pacific Northwest National Laboratory	10/1/2011 – 5/31/2016
Waste Heat Integration	Southern Company Services	10/1/2011 – 5/31/2016
Amine Solvent in Ionic Liquid	ION Engineering, LLC	10/1/2010 – 3/31/2016

Project Focus	Participant	Performance Period
Ammonia- and Potassium Carbonate-Based Mixed-Salt Solvent	SRI International	10/1/2013 – 3/31/2016
Nonaqueous Solvent	RTI International	10/1/2013 – 3/31/2016
Novel Aminosilicone Solvent	GE Global Research	10/1/2008 – 12/31/2015
Novel Absorption/Stripper Process	William Marsh Rice University	10/1/2011 – 12/31/2015
Piperazine Solvent with Flash Regeneration	URS Group	10/1/2010 – 9/30/2015
COMPLETED		
Enzyme and Vacuum Combination Technology	Novozymes	10/1/2011 – 6/30/2015
Gas-Pressurized Stripping	Carbon Capture Scientific	10/1/2011 – 6/30/2015
Carbon Absorber Retrofit Equipment	Neumann Systems Group	1/2/2012 – 1/31/2015
Optimized Solvent Formulation	Babcock & Wilcox	10/1/2011 – 4/30/2014
Hot Carbonate Absorption with Crystallization-Enabled High-Pressure Stripping	University of Illinois at Urbana-Champaign	1/1/2011 – 3/31/2014
Chemical Additives for CO ₂ Capture	Lawrence Berkeley National Laboratory	6/1/2008 – 5/31/2013
CO ₂ Capture with Self-Concentrating Amine Absorbent	3H Company	10/1/2010 – 1/31/2013
Ionic Liquids	University of Notre Dame	2/28/2007 – 9/30/2012
Novel Integrated Vacuum Carbonate Process	Illinois State Geological Survey	10/1/2008 – 4/30/2012
POSTCAP Capture and Separation	Siemens Energy	10/1/2010 – 2/29/2012
Reversible Ionic Liquids	Georgia Tech Research Corporation	10/1/2008 – 9/30/2011
Phase Transitional Absorption	Hampton University	6/15/2005 – 6/30/2009

POST-COMBUSTION SORBENT TECHNOLOGIES

DOE/NETL's R&D objectives for post-combustion sorbents include development of low-cost, durable sorbents that have high selectivity, high CO₂ adsorption capacity, and can withstand multiple regeneration cycles.

Project Focus	Participant	Performance Period
ACTIVE		
Novel Solid Sorbent	SRI International	10/1/2008 – 3/31/2018
Alkalized Alumina Solid Sorbent	TDA Research, Inc.	11/1/2008 – 12/31/2017
Advanced Aerogel Sorbents	Aspen Aerogels, Inc.	10/1/2013 – 9/30/2016
Rapid Pressure Swing Adsorption	WR Grace	5/1/2012 – 7/31/2016
Advanced Solid Sorbents and Processes for CO ₂ Capture	RTI International	10/1/2011 – 12/31/2015
Low-Cost, High-Capacity Regenerable Sorbent	TDA Research, Inc.	10/1/2011 – 9/30/2015
Solid Sorbents as Retrofit Technology	ADA-ES, Inc.	9/30/2008 – 9/30/2015
COMPLETED		
Cross-Heat Exchanger for Sorbent-Based CO ₂ Capture	ADA-ES, Inc.	10/1/2013 – 6/15/2015
Novel Adsorption Process	InnoSeptra, LLC	10/1/2011 – 3/31/2015
Rapid Temperature Swing Adsorption	Georgia Institute of Technology	10/1/2011 – 3/31/2015
Solid Sorbent-Based CO ₂ Capture	University of North Dakota	10/1/2011 – 12/31/2014
Metal Monolithic Amine-Grafted Zeolites	University of Akron	2/21/2007 – 3/31/2011
CO ₂ Removal from Flue Gas Using Microporous MOFs	UOP	3/12/2007 – 6/30/2010
A Dry Sorbent-Based Post Combustion CO ₂ Capture	RTI International	3/7/2007 – 12/31/2009

POST-COMBUSTION MEMBRANE TECHNOLOGIES

DOE/NETL's R&D objectives for post-combustion membranes include development of low-cost, durable membranes that have improved permeability and selectivity, thermal and physical stability, and tolerance to contaminants in combustion flue gas.

Project Focus	Participant	Performance Period
ACTIVE		
Hollow-Fiber-Membrane Contactor with aMDEA Solvent	Gas Technology Institute	10/1/2010 – 6/30/2018
Hybrid Membrane, Amine Absorption	Membrane Technology and Research, Inc.	10/1/2013 – 9/30/2017
Supersonic Inertial CO ₂ Extraction System	Orbital ATK, Inc.	10/1/2013 – 9/30/2016
Subambient Temperature Membrane	American Air Liquide, Inc.	10/1/2010 – 3/31/2016
Inorganic/Polymer Composite Membrane	Ohio State University	10/1/2011 – 12/31/2015
Polymeric Membranes	Membrane Technology and Research, Inc.	4/1/2007 – 9/30/2015
Electrochemical Membrane	FuelCell Energy, Inc.	10/1/2011 – 8/31/2015
COMPLETED		
Composite Hollow Fiber Membranes	General Electric Global Research Center	10/1/2011 – 12/31/2014
Low-Pressure Membrane Contactors (Mega-Module)	Membrane Technology and Research, Inc.	10/1/2011 – 9/30/2014
Hollow-Fiber, Polymeric Membrane	Research Triangle Institute	9/26/2008 – 9/30/2011
Biomimetic Membrane	Carbozyme	3/28/2007 – 7/31/2009
Dual Functional, Silica-Based Membrane	University of New Mexico	8/23/2004 – 4/30/2009

PRE-COMBUSTION SOLVENT TECHNOLOGIES

Pre-combustion solvent R&D activities focus on addressing solvent technology challenges including increasing CO₂ loading capacity and reaction kinetics coupled with decreasing regeneration energy.

Project Focus	Participant	Performance Period
ACTIVE		
CO ₂ Capture Using AC-ABC Process	SRI International	9/30/2009 – 9/30/2015

PRE-COMBUSTION SORBENT TECHNOLOGIES

DOE/NETL is developing solid sorbents for pre-combustion CO₂ capture aimed at improving the cost and performance of IGCC CO₂ separation. These sorbents must maintain a high adsorption loading capacity, be resistant to attrition over multiple regeneration cycles, and exhibit good performance at the high temperatures encountered in IGCC systems to avoid the need for syngas cooling and reheating.

Project Focus	Participant	Performance Period
ACTIVE		
High Capacity Regenerable Sorbent	TDA Research, Inc.	10/1/2013 – 9/30/2017
COMPLETED		
Sorbent Development for WGS	URS Group, Inc.	1/1/2010 – 9/30/2013

PRE-COMBUSTION MEMBRANE TECHNOLOGIES

Several advanced membrane technology options are under development by DOE/NETL to separate CO₂ and hydrogen in coal-derived syngas. Membrane designs include metallic, polymeric, or ceramic materials operating at elevated temperatures and using a variety of chemical and/or physical mechanisms for separation. Successful membranes must have high permeability and selectivity with low pressure drop, tolerance to contaminants (e.g., sulfur), and be capable of operation at system temperatures up to 500 °F.

Project Focus	Participant	Performance Period
ACTIVE		
PBI Polymer Membrane	SRI International	10/1/2013 – 10/31/2016
Two-Stage Membrane Separation: Carbon Molecular Sieve Membrane Reactor followed by Pd-Based Membrane	Media and Process Technology, Inc.	10/1/2013 – 9/30/2016
High-Temperature Polymer-Based Membrane	Los Alamos National Laboratory	10/1/2008 – 3/31/2016
COMPLETED		
Dual-Phase Ceramic-Carbonate Membrane Reactor	Arizona State University	10/1/2009 – 9/30/2014
Pd-Alloys for Sulfur/Carbon Resistance	Pall Corporation	10/1/2009 – 9/30/2014
Hydrogen-Selective Zeolite Membranes	University of Minnesota	10/1/2009 – 9/30/2014
Pressure Swing Membrane Absorption Device and Process	New Jersey Institute of Technology	10/1/2009 – 3/31/2013
Nanoporous, Superhydrophobic Membrane Contactor Process	Gas Technology Institute	10/1/2009 – 3/31/2012
Polymer Membrane Process Development	Membrane Technology and Research, Inc.	9/14/2009 – 9/14/2011

ADVANCED COMPRESSION TECHNOLOGIES

To reduce CO₂ compression costs, DOE/NETL has developed novel concepts for large-scale CO₂ compression. Various concepts have been evaluated using computational fluid dynamics and laboratory testing, leading to prototype development and field testing.

Project Focus	Participant	Performance Period
COMPLETED		
Shock Wave Compression	Ramgen Power Systems	5/10/2006 – 3/31/2015
Evaluation of Compression Efficiency Improvements	Southwest Research Institute	9/28/2005 – 6/30/2014

R&D COLLABORATIONS

DOE/NETL has also participated in R&D collaborations exploring multiple approaches to CO₂ capture for coal-based power plants and modeling the economic and emissions reduction impact of carbon capture R&D.

Project Focus	Participant	Performance Period
COMPLETED		
Partnership for CO ₂ Capture	University of North Dakota Energy and Environmental Research Center	6/30/2008 – 6/30/2015
Analysis of CCS Technology Adoption	Argonne National Laboratory	2/1/2011 – 3/31/2014

NATIONAL ENERGY TECHNOLOGY LABORATORY—RESEARCH AND INNOVATION CENTER TECHNOLOGIES

10

Onsite research at NETL in CO₂ capture leverages cutting-edge research facilities, world-class scientists and engineers, state-of-the-art computational modeling and simulation tools, and strategic collaborations to foster the discovery, development, and demonstration of solvents, sorbents, and membranes.

Project Focus	Participant	Performance Period
ACTIVE		
Pre- and Post-Combustion Liquid Solvents	National Energy Technology Laboratory—Research and Innovation Center Technologies	10/1/2015 – 9/30/2016
Pre- and Post-Combustion Solid Sorbent Materials	National Energy Technology Laboratory—Research and Innovation Center Technologies	10/1/2015 – 9/30/2016
Pre- and Post-Combustion Membrane Materials	National Energy Technology Laboratory—Research and Innovation Center Technologies	10/1/2015 – 9/30/2016
High-Throughput Computational Tools	National Energy Technology Laboratory—Research and Innovation Center Technologies	10/1/2015 – 9/30/2016
Carbon Capture Simulation for Industry Impact	National Energy Technology Laboratory—Research and Innovation Center Technologies	10/1/2015 – 9/30/2016

this page intentionally left blank

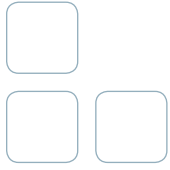

POST-COMBUSTION SOLVENT TECHNOLOGIES



BENCH-SCALE PROCESS FOR LOW-COST CARBON DIOXIDE CAPTURE USING A PHASE-CHANGING ABSORBENT

primary project goals

GE Global Research is designing and building a bench-scale process using a novel phase-changing aminosilicone-based carbon dioxide (CO₂)-capture solvent (absorbent) to establish scalability and technical and economic feasibility of using a phase-changing CO₂-capture absorbent for post-combustion capture, with the ultimate goal of achieving an overall reduction in CO₂ capture cost.

technical goals

- Design and build a bench-scale system for post-combustion CO₂ capture using a phase-changing aminosilicone-based solvent.
- Develop preliminary process and cost models.
- Conduct bench-scale testing on unit operations to evaluate performance and define parameters for scaleup.
- Evaluate materials of construction, manufacturability of solvent, assemble continuous bench-scale system, and update the process model.
- Perform testing on continuous system to optimize process parameters.
- Perform EH&S and techno-economic assessments and devise scaleup strategy.

technical content

GE Global Research is designing and optimizing a new process for a phase-changing CO₂ capture solvent for use in post-combustion capture in coal-fired power plants. The process is based on the use of the silicone-based phase change solvent (GAP-0), which was developed at the lab-scale in a previous ARPA-E project (DE-AR0000084). The liquid solvent rapidly absorbs CO₂ at low temperatures (40–50 °C) with high loading (>17 percent weight gain) to form a solid carbamate salt. The carbamate salt readily decarboxylates at high temperatures. The innovative process is designed to make use of the unique phase-change properties of the aminosilicone solvent.

The process, shown in Figure 1, starts in the absorber, where the liquid phase-changing solvent is sprayed in fine droplets into the flue gas, reacting with the CO₂ to form solid particles. The solids are conveyed in an extruder, moving from the low-temperature, low-pressure absorber to the high-temperature, high-pressure desorber. The unique design of the extruder permits heating and compression of the solids, allowing for continuous delivery of the solids into the pressurized desorber. The solids are heated in the desorber, leading to decarboxylation. CO₂ is separated from the liquid phase-changing solvent in the desorber, allowing for recovery of the CO₂ and recycle of the solvent.

technology maturity:

**Bench-Scale, Simulated
Flue Gas**

project focus:

**Phase-Changing
Absorbent**

participant:

GE Global Research

project number:

FE0013687

NETL project manager:

David Lang
david.lang@netl.doe.gov

principal investigator:

Tiffany Westendorf
GE Global Research
westendo@research.ge.com

partners:

Coperion Corporation

performance period:

1/1/14 – 12/31/16

Testing of the bench-scale system will provide data, including mass transfer parameters, kinetic parameters, heat transfer parameters, solvent stability, effects of flue gas contaminants, and recommended operating conditions, to perform a techno-economic assessment and develop a scaleup strategy. The project aims to establish scalability and technical and economic feasibility of using a phase-changing CO₂-capture absorbent for post-combustion capture of CO₂ from coal-fired power plants with 90 percent capture efficiency and 95 percent CO₂ purity at a cost of \$40/tonne of CO₂ captured.

The solvent and process parameters identified to date are provided in Table 1.

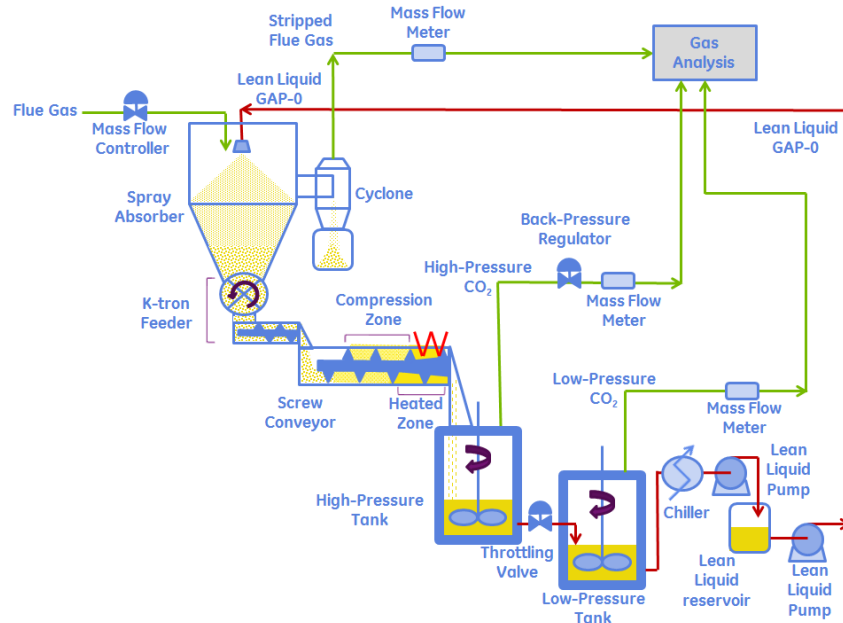

Figure 1: Phase-Changing Absorbent Process

TABLE 1: PROCESS PARAMETERS FOR PHASE-CHANGING SOLVENTS

	Units	Current R&D Value	Target R&D Value
Pure Solvent			
Molecular Weight	mol ⁻¹	248.51	248.51
Normal Boiling Point	°C	258.7	258.7
Normal Freezing Point	°C	-85	-85
Vapor Pressure at 15 °C	bar	1.8x10 ⁻⁵	1.8x10 ⁻⁵
Manufacturing Cost for Solvent	\$/kg	TBD	TBD
Working Solution			
Concentration	kg/kg	1	1
Specific Gravity (15 °C/15 °C)	—	0.891	0.891
Specific Heat Capacity at STP	kJ/kg-K	2.29	2.29
Viscosity at STP	cP	4.4	4.4
Absorption			
Pressure	bar	1	1
Temperature	°C	30	30
Equilibrium CO ₂ Loading	mol/mol	0.9-1	0.9-1
Heat of Absorption	kJ/mol CO ₂	-105.6	-105.6
Solution Viscosity	cP	N/A	N/A

TABLE 1: PROCESS PARAMETERS FOR PHASE-CHANGING SOLVENTS

	Units	Current R&D Value	Target R&D Value
Desorption			
Pressure	bar	7	7
Temperature	°C	160	160
Equilibrium CO ₂ Loading	mol/mol	0.34	0.34
Heat of Desorption	kJ/mol CO ₂	-105.6	-105.6
Proposed Module Design		<i>(for equipment developers)</i>	
Flue Gas Flowrate	kg/hr	2,767,497	
CO ₂ Recovery, Purity, and Pressure	%%/bar	90% / 95% / 150 bar	
Absorber Pressure Drop	bar	TBD	

Definitions:

STP – Standard Temperature and Pressure (15 °C, 1 atm).

Pure Solvent – Chemical agent(s), working alone or as a component of a working solution, responsible for enhanced CO₂ absorption (e.g., the amine MEA in an aqueous solution).

Manufacturing Cost for Solvent – “Current” is market price of chemical, if applicable; “Target” is estimated manufacturing cost for new solvents, or the estimated cost of bulk manufacturing for existing solvents.

Working Solution – The solute-free (i.e., CO₂-free) liquid solution used as the working solvent in the absorption/desorption process (e.g., the liquid mixture of MEA and water).

Absorption – The conditions of interest for absorption are those that prevail at maximum solvent loading, which typically occurs at the bottom of the absorption column. These may be assumed to be 1 atm total flue-gas pressure (corresponding to a CO₂ partial pressure of 0.13 bar) and 40 °C; however, measured data at other conditions are preferable to estimated data.

Desorption – The conditions of interest for desorption are those that prevail at minimum solvent loading, which typically occurs at the bottom of the desorption column. Operating pressure and temperature for the desorber/stripper are process-dependent (e.g., an MEA-based absorption system has a typical CO₂ partial pressure of 1.8 bar and a reboiler temperature of 120 °C). Measured data at other conditions are preferable to estimated data.

Pressure – The pressure of CO₂ in equilibrium with the solution. If the vapor phase is pure CO₂, this is the total pressure; if it is a mixture of gases, this is the partial pressure of CO₂. Note that for a typical PC power plant, the total pressure of the flue gas is about 1 atm and the concentration of CO₂ is about 13.2 percent. Therefore, the partial pressure of CO₂ is roughly 0.132 atm or 0.130 bar.

Concentration – Mass fraction of pure solvent in working solution.

Loading – The basis for CO₂ loadings is moles of pure solvent.

Other Parameter Descriptions:

Chemical/Physical Solvent Mechanism – Chemical absorption

Solvent Contaminant Resistance – Solvent absorbs SO₂, forming heat-stable salts.

Solvent Foaming Tendency – Limited.

Flue Gas Pretreatment Requirements – Flue gas desulfurization, cooling to <40 °C.

Solvent Makeup Requirements – TBD

Waste Streams Generated – In the commercial scale process, a small slipstream of the phase-changing absorbent may be purged from the process to limit accumulation of sulfur compounds in the solvent. This will be analyzed in greater detail in the upcoming EH&S Risk Assessment, to be completed by 3/31/2016.

Process Design Concept – See Figure 1 above.

Proposed Module Design – Unless noted, flue gas feed pressure is 14.7 psia, temperature is 135 °F, and composition leaving the flue gas desulfurization (FGD) unit (wet basis) should be assumed:

Composition (% vol)					Composition (ppmv)	
CO ₂	H ₂ O	N ₂	O ₂	Ar	SO _x	NO _x
13.17	17.25	66.44	2.34	0.8	42	74

technology advantages

- Non-aqueous, pure solvent.
- Superior properties compared to reference case (MEA) results in potential for cost reduction.
 - Lower heat capacity.
 - Low corrosivity.
 - High thermal stability.
 - Low vapor pressure.
- High CO₂ loading and intensified mass transfer requires smaller equipment.
- Pressurized desorption reduces CO₂ compression duty and capital cost.

R&D challenges

- Cost and availability of the solvent.
- Effect of thermal degradation of solvent to higher GAP homologs on ability to form easily handled carbamate salts.
- Scaleup of the extruder to maintain effective hydrodynamic seal and provide for efficient heat transfer, decarboxylation, and pressurized solids transport.
- Maintenance of effective pressurized solids handling in the system.
- Development of correlations between the primary system variables and unit operations performance to determine scaleup effects, particularly on heat transfer in the absorber and desorber.

results to date/accomplishments

- Completed conceptual design and initial P&ID's for bench-scale system.
- Installed bench-scale unit operation equipment, completed internal safety reviews.
- Completed conceptual scheme for integration of bench-scale unit operations into system.
- Secured lower price for phase-change solvent for bench scale project.
- Confirmed through testing and visual inspection of solvent mixtures that presence of solvent thermal degradation products are not expected to interfere with quality of solids needed for the phase-change process, within conditions investigated to date.
- Updated process and economic models to reflect best available data for solvent properties and system performance.

next steps

- Complete commissioning of all unit operations.
- Develop and execute experimental plan for unit ops testing.
- Complete process modeling for optimization to maximize energy efficiency, validate model with experimental data from bench-scale testing results.

available reports/technical papers/presentations

“Bench-Scale Process for Low-Cost CO₂ Capture Using a Phase-Changing Absorbent,” Presented by Tiffany Westendorf, GE Global Research, 2014 NETL CO₂ Capture Technology Meeting, Pittsburgh, PA, July 2014. [http://www.netl.doe.gov/File Library/Events/2014/2014 NETL CO₂ Capture/T-Westendorf-GE-Phase-Changing-Absorbent.pdf](http://www.netl.doe.gov/File%20Library/Events/2014/2014%20NETL%20CO2%20Capture/T-Westendorf-GE-Phase-Changing-Absorbent.pdf).

“Bench-Scale Process for Low-Cost CO₂ Capture Using a Phase-Changing Absorbent,” Project Kick-Off Meeting Presentation, Pittsburgh, PA, November 20, 2013. [http://www.netl.doe.gov/File Library/Research/Coal/carbon capture/post-combustion/2013-11-20-Kickoff-Meeting-GE-FE0013687.pdf](http://www.netl.doe.gov/File%20Library/Research/Coal/carbon%20capture/post-combustion/2013-11-20-Kickoff-Meeting-GE-FE0013687.pdf).

AN ADVANCED CATALYTIC SOLVENT FOR LOWER COST POST-COMBUSTION CO₂ CAPTURE IN A COAL-FIRED POWER PLANT

primary project goals

The University of Kentucky Center for Applied Energy Research (CAER) team is developing and validating, at bench scale, a cost-effective CO₂ capture process that combines a catalyzed advanced amine solvent and the CAER membrane-based solution enrichment technology with the CAER heat-integration process to achieve an overall reduction in CO₂ capture cost.

technical goals

- Conduct baseline parametric testing of the advanced amine solvent on the closed-loop heat-integrated 0.1 MWth bench-scale unit at CAER with coal-derived flue gas.
- Conduct a long-term verification study to assess catalyst and solvent stability at process conditions.
- Improve catalyst and membrane performance and reduce production cost.
- Identify effective method to mitigate accumulation of heavy metals in solution.
- Integrate a membrane solvent dewatering module or a membrane pre-concentrating CO₂ module into the bench-scale unit and conduct testing to show further process energy reduction.
- Complete a techno-economic feasibility study and an environmental, health, and safety assessment.

technical content

The CAER team is developing and validating at bench-scale a cost-effective CO₂ capture process that combines a catalyzed advanced amine solvent and membrane-based carbon enrichment technology with a heat-integration process. This system combines several of the technologies developed by CAER to improve overall carbon capture cost (Figure 1).

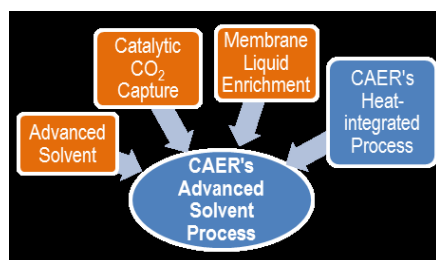

Figure 1: Technologies Combined into CAER's Advanced Solvent Process

technology maturity:

Bench-Scale, Coal-Derived Flue Gas

project focus:

Hybrid Membrane/Advanced Catalyst Solvent

participant:

Center for Applied Energy Research, University of Kentucky

project number:

FE0012926

NETL project manager:

José Figueroa
jose.figueroa@netl.doe.gov

principal investigator:

Kunlei Liu
University of Kentucky
Research Foundation
kunlei.liu@uky.edu

partners:

WorleyParsons, Smith Management Group, Carbon Management Research Group (CMRG)

performance period:

10/1/13 – 12/31/16

The proposed catalytic solvent process with membrane is shown in Figure 2.

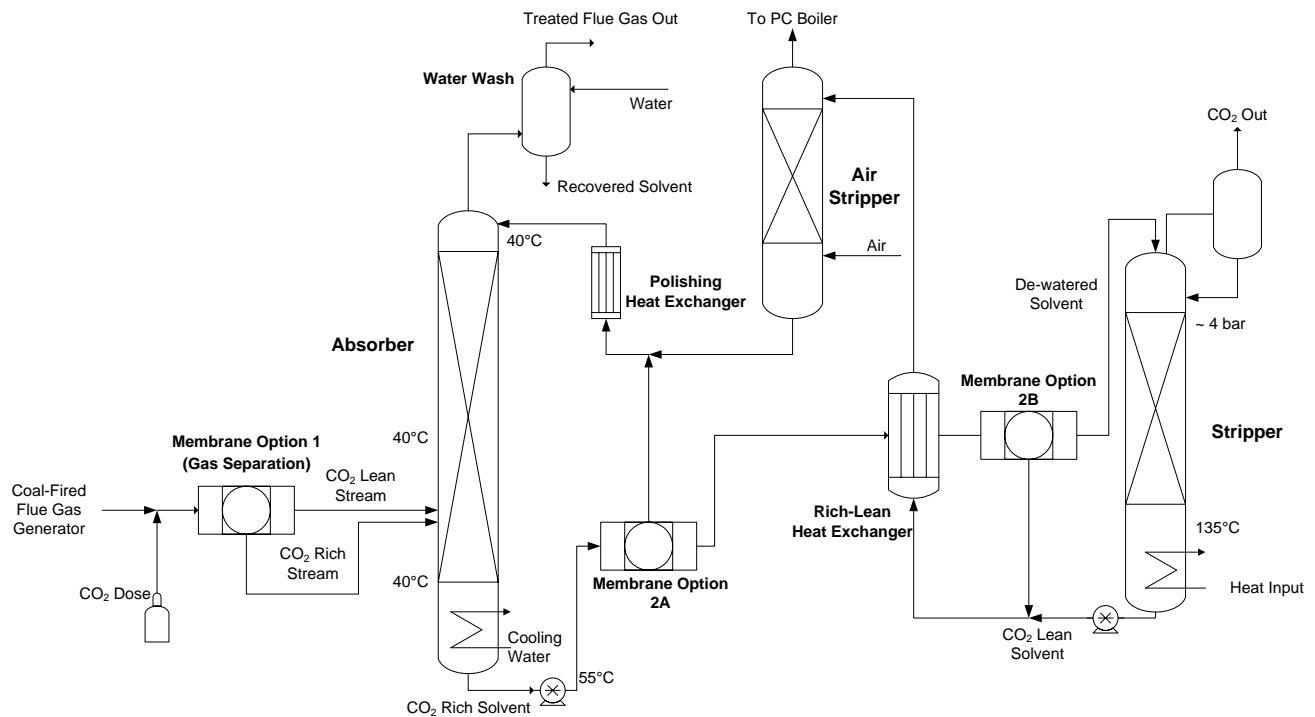

Figure 2: UK CAER's Catalytic Solvent Process

The novel catalytic amine solvent utilizes an organometallic homogeneous catalyst to enhance CO₂ absorption kinetics. Mass transfer rate increases of 15–40 percent are possible from using the catalytic advanced amine solvent over uncatalyzed amine solvent, resulting in more efficient absorption of the CO₂, increased rich CO₂ stream concentration, and decreased absorber size requirements. Improved solvent thermal stability allows the solvent to be used in the high temperature stripper conditions utilized in this process. Additional improvements from the catalytic solvent include increased cyclic capacity, reduced solvent loss and makeup requirements, and lower energy regeneration.

An integrated membrane carbon enrichment process is combined with the advanced catalytic solvent to provide enrichment of the CO₂ rich amine solvent from the bottom of the absorber. For the liquid-based membrane configuration (2A or 2B in Figure 2), the unique design of the membrane selectively permeates water from the stream for recycle to the absorber, as shown in Figure 3, effectively concentrating the CO₂ rich stream and increasing the CO₂ partial pressure, which can further reduce process energy. This membrane should be designed to maximize water permeability and carbon rejection, while maintaining stable performance over time.

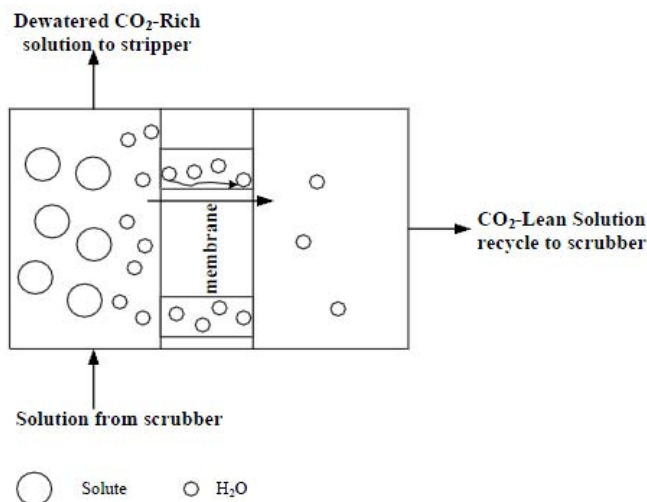

Figure 3: Membrane Dewatering for CO₂ Enrichment

Parametric testing and long-term verification tests using CAER’s bench-scale closed loop, heat integrated 0.1 MWth unit are used to optimize and demonstrate the process. Data from testing is used to complete a techno-economic analysis and to develop an ASPEN process model for a proposed process concept for a 550-MW power plant utilizing the CAER advanced solvent technology.

The solvent and process parameters identified to date are provided in Table 1.

TABLE 1: UK-CAER SOLVENT MAJOR PROCESS PARAMETERS

	Units	Current R&D Value	Target R&D Value
Pure Solvent			
Molecular Weight	mol ⁻¹	<90 g	<90 g
Normal Boiling Point	°C	160–165	160–165
Normal Freezing Point	°C	-2	-2
Vapor Pressure at 15 °C	bar	6.3 x 10 ⁻⁴	6.3 x 10 ⁻⁴
Manufacturing Cost for Solvent	\$/kg	4–6 (estimated)	3–5
Solvent Properties			
Concentration	kg/kg	0.39	0.45
Specific Gravity (15 °C/15 °C)	g/mL	1.01	1.0
Specific Heat Capacity at STP	kJ/kg-K	3.4	3.3
Viscosity at STP	cP	3.04	3.3
Process Conditions			
Pressure	bar	0.1	0.1
Temperature	°C	40	40
Equilibrium CO ₂ Loading	mol/mol	0.42	0.45
Heat of Absorption	kJ/mol CO ₂	74	72
Solution Viscosity	cP	4.88	5.9
Process Conditions (Stripper)			
Pressure	bar	3.1	4.2
Temperature	°C	125	135
Equilibrium CO ₂ Loading	mol/mol	0.23	0.23
Heat of Desorption	kJ/mol CO ₂	84	84

Definitions:

STP – Standard Temperature and Pressure (15 °C, 1 atm).

Pure Solvent – Chemical agent(s), working alone or as a component of a working solution, responsible for enhanced CO₂ absorption (e.g., the amine MEA in an aqueous solution).

Manufacturing Cost for Solvent – “Current” is market price of chemical, if applicable; “Target” is estimated manufacturing cost for new solvents, or the estimated cost of bulk manufacturing for existing solvents.

Working Solution – The solute-free (i.e., CO₂-free) liquid solution used as the working solvent in the absorption/desorption process (e.g., the liquid mixture of MEA and water).

Absorption – The conditions of interest for absorption are those that prevail at maximum solvent loading, which typically occurs at the bottom of the absorption column. These may be assumed to be 1 atm total flue-gas pressure (corresponding to a CO₂ partial pressure of 0.13 bar) and 40 °C; however, measured data at other conditions are preferable to estimated data.

Desorption – The conditions of interest for desorption are those that prevail at minimum solvent loading, which typically occurs at the bottom of the desorption column. Operating pressure and temperature for the desorber/stripper are process-dependent (e.g., an MEA-based absorption system has a typical CO₂ partial pressure of 1.8 bar and a reboiler temperature of 120 °C). Measured data at other conditions are preferable to estimated data.

Pressure – The pressure of CO₂ in equilibrium with the solution. If the vapor phase is pure CO₂, this is the total pressure; if it is a mixture of gases, this is the partial pressure of CO₂. Note that for a typical PC power plant, the total pressure of the flue gas is about 1 atm and the concentration of CO₂ is about 13.2 percent. Therefore, the partial pressure of CO₂ is roughly 0.132 atm or 0.130 bar.

Concentration – Mass fraction of pure solvent in working solution.

Loading – The basis for CO₂ loadings is moles of pure solvent.

Estimated Cost – Basis is kg/hr of CO₂ in CO₂-rich product gas; assuming targets are met.

Other Parameter Descriptions:

Chemical/Physical Solvent Mechanism – The absorption reactions for any amine based system can be broken into two primary reactions as depicted in Figure 4 below. The absorption of CO₂ is primarily dictated by the reactions of primary amine (SC) to form carbamates. The reaction second order rate constant for these species can vary but is generally on the order of (10³ l/mol·s) with similar rate constants observed for CAER-B3. The SC reaction generates a mole of proton for each mol of CO₂ capture leading to primary amines being generally limited on a molar basis to 0.5 CO₂:1N. The CAER-B3 amine solvent utilizes a primary amine as the main component; additionally, another minor component is added to the solvent to principally act as a proton receiver (PC) in the solution freeing more of the main component to react with CO₂. The pKa of this proton receiver is higher (more basic) than that of the main component meaning that this species preferentially associates with the proton allowing more of the main component to react with CO₂. The reaction from the proton receiver to directly form bicarbonate is much slower (100x). The catalyst in this work is intended as a Carbonic Anhydrase mimetic structure. Thus, it is expected to function similarly to those enzymes in directly catalyzing the reaction of dissolved CO₂ in solution to form bicarbonate. A third reaction to form bicarbonate directly from hydroxide present in solution can generally be excluded from consideration despite the fast rate constant (10⁴ l/mol·s) because hydroxide concentration is limited by the base dissociation constant in typical amine solutions (<1 x 10⁻⁴).

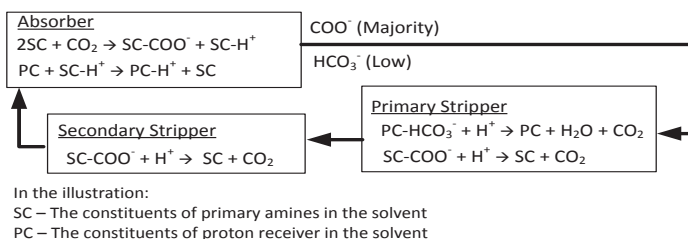

Figure 4: Schematic for Reactions Occurring in the CO2 Capture Cycle

Solvent Contaminant Resistance – The CAER-B3 solvent shows analogous behavior towards oxidation and flue gas components as 30 percent MEA. We anticipate similar levels or less of oxidation and degradation due to flue gas components.

Solvent Foaming Tendency – The catalytic solvent has very low foaming tendencies due to a low surface tension of <40dyn/cm. The foaming observed is less than 30 percent MEA, but more than 30 percent MEA with antifoam added.

Flue Gas Pretreatment Requirements – Flue gas from the flue gas generator goes through a solid separator where particulate matter is initially removed before being treated in a wet desulfurization process to lower SO₂ concentration typically below 100 ppm to reduce undesirable competitive reaction with the solvent. After SO₂ removal, the flue gas goes through a knock-out drum for final particulate and liquid droplet removal before it is sent to the CO₂ capture unit.

Solvent Makeup Requirements – The CAER-B3 solvent is composed of amines that are inherently more stable than MEA. The CAER-B3 solvent has a high thermal stability compared to reference MEA. As seen in Figure 5, a 50–70 percent decrease in rate of amine loss as percent of initial is observed at the high temperatures associated with stripper conditions over a 2 week period. Regression of the data compared to reference MEA predicts a thermal degradation rate similar to MEA at a 10 °C higher stripper operating temperature. It is expected that the makeup requirements will be similar to that of MEA under the proposed process conditions of a higher stripper temperature/pressure.

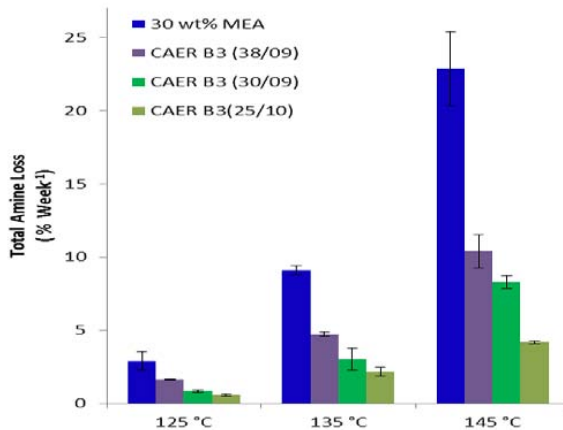

Figure 5: Rate of Amine Loss as Total Percent Amine under Stripper Conditions of 30 wt% MEA (Blue) and Various Combinations of CAER-B3

Waste Streams Generated – The waste streams generated from the process are the spent soda ash solution and CAER-B3 solvent used for SO₂ removal and the absorption of CO₂, respectively. The loss of performance and how quickly the solvent is spent is impacted by the rate of degradation and heat stable salts formation in the solvent.

Process Design Concept – Flowsheet/block flow diagrams are included above. In brief, the SO₂-polished flue gas (from the pre-treatment tower) enters the CO₂ pre-concentration membrane to produce two streams entering CO₂ absorber via different locations. After gaseous CO₂ is converted into aqueous carbon species, the carbon-rich solution exits the scrubber bottom, is pressurized, and is sent to the rich-lean solution heat exchanger (Crossover EHX) prior to the dewatering membrane unit. The permeate stream of the dewatering membrane unit with low amine concentration combines with the regenerated lean solution stream exiting at the outlet of the stripper. The reject stream which has higher carbon loading than the feed stream is sent to the top of pressurized stripper for solvent regeneration. This stage will require an energy source to drive the reboiler. At the stripper exit, the gas stream consists primarily of CO₂ and water vapor at a pressure of approximately 3 bar. After exiting the heat recovery unit at the top of stripper, the CO₂ gas stream with purity of >95 percent will be pressurized to about 135 bar and intercooled for downstream utilization or sequestration. The carbon-lean solution exiting the primary stripper is sent to the Crossover EHX, where heat will be recovered with the carbon rich solution. After the Crossover EHX, this heat depleted stream will be cooled to approximately 40 °C and recycled to the scrubber.

Proposed Module Design – The proposed bench-scale study is being conducted at the CAER’s 0.1MWth heat-integrated post-combustion CO₂ capture facility. The CAER bench-scale-plant consists of a 24 ft tall by 4 in ID PVC scrubber with a internally cooled storage tank at bottom, solvent recovery unit in the scrubber exhaust stream, two stainless steel heat exchangers (for cross-flow heat recovery and polishing cooling of the CO₂-lean solution, respectively), a 14 ft tall stainless steel stripper, and a condenser for solvent recovery in the stripper exhaust. A hot-oil system and a chiller are installed to provide necessary heat for solvent regeneration and solution temperature control. There are three high pressure pumps to connect the scrubber and the stripper. Unless noted, flue gas feed pressure is 14.7 psia, temperature is 135 °F, and composition leaving the flue gas desulfurization (FGD) unit (wet basis) should be assumed:

Composition (% vol)					Composition (ppmv)	
CO ₂	H ₂ O	N ₂	O ₂	Ar	SO _x	NO _x
13.17	17.25	66.44	2.34	0.80	42	74

The entire process is fully integrated and utilizes a custom built National Instruments LabVIEW control system. Inlet and outlet CO₂ concentrations are continuously monitored and other acid gas contaminants are monitored at the scrubber inlet using a multi-gas (5) analyzer. Instrumentation on the unit allows constant monitoring of CO₂ capture, lean and rich solution pH and amine concentration (allows rich and lean to be estimated during operation), temperatures of process units, liquid flow rates, and gas flow rates. Process energy consumption is monitored using energy meters on the chiller (rich solution cooling, lean solution polishing, and stripper condenser) and reboiler. Liquid samples are taken periodically for offline measurements to determine alkalinity (titration), CO₂ loading (acid evolution of gas), pH (for verification) and density.

technology advantages

- Potential for reduced capital cost for post-combustion CO₂ capture.
 - Increased absorption kinetics (smaller absorber).
- Potential for reduced energy consumption compared to reference case (MEA).
 - High cyclic capacity.
 - High stripper temperatures/pressure.
 - Less solvent makeup rate.

R&D challenges

- Parameters for synthesis of an effective membrane are sensitive to optimization. Small synthesis changes produce large performance variance.
- Transition from lab- to bench-scale process under real flue gas conditions.
- Solvent oxidation via catalyst addition.
- Integration with multiple technologies.

results to date/accomplishments

- Confirmed catalytic solvent is commercially available.
- Developed robust catalysts.
 - Shown to maintain enhancement after heating at 145 °C for 100 hours.
 - Negligible effect from NO_x and SO_x components.
- Vapor-liquid equilibrium (VLE) and regression obtained.
 - Data used for ASPEN modeling for TEA.
- Further tuned the zeolite membrane thickness to balance the flux while maintaining selectivity.
- Achieved membrane performance of >5 percent dewatering.

next steps

- Testing in 0.1-MWth bench-scale unit.
 - Baseline testing, parametric catalytic solvent testing.
 - Short-term degradation analysis.
- Membrane improvement and module design for pilot integration.

available reports/technical papers/presentations

“An Advanced Catalytic Solvent for Lower Cost Post-Combustion CO₂ Capture in a Coal-Fired Power Plant,” Project Review Meeting, Pittsburgh, PA, October 2014. <http://www.netl.doe.gov/File%20Library/Research/Coal/carbon%20capture/post-combustion/DE-FE0012926-BP1-review-meeting.pdf>.

Cameron, L., Landon, J., Liu, K., Sarma, M., Franca, R., and Qi, G., “An Advanced Catalytic Solvent for Lower Cost Post-Combustion CO₂ Capture in a Coal-Fired Power Plant,” 2014 NETL CO₂ Capture Technology Meeting, Pittsburgh, PA, July 2014. <http://www.netl.doe.gov/File%20Library/Events/2014/2014%20NETL%20CO2%20Capture/C-Lippert-CAER-UK-Advanced-Catalytic-Solvent.pdf>.

Lui, K. and Lippert, C., “An Advanced Catalytic Solvent for Lower Cost Post-Combustion CO₂ Capture in a Coal-Fired Power Plant.” Project Kick-Off Meeting, Pittsburgh PA December 2013. <http://www.netl.doe.gov/File%20Library/Research/Coal/carbon%20capture/post-combustion/UKRF-Catalytic-Solvent-Public.pdf>.

NOVEL FLOW SHEET FOR LOW-ENERGY CO₂ CAPTURE ENABLED BY BIOCATALYST DELIVERY SYSTEM

primary project goals

Akermin is developing an advanced biocatalyst enabled solvent system for lower cost carbon dioxide (CO₂) capture. The project focuses on the development of encapsulated carbonic anhydrase (CA) biocatalyst technology, initially developed in project DE-FE0004228. This phase adds improvements to the solvent and process to achieve a much lower cost of capture. The project combines an improved biocatalyst delivery system (BDS), a new solvent, and process improvements that will be tested in a modified bench-scale system incorporating these new advancements. The overall goal is to demonstrate its effectiveness toward achieving \$40/tonne CO₂ cost of capture.

technical goals

- Demonstrate a second-generation biocatalyst that has lower production costs, is more readily scaled up, and enables on-stream catalyst replacement.
- Demonstrate consistent long-term performance in lab-scale closed loop reactor.
- Design and modify bench-scale test unit to incorporate the next-generation BDS and to accommodate the novel process improvements.
- Optimize the process flow sheet to utilize low grade steam for solution regeneration and to achieve parasitic power less than 220-kWh/t CO₂.
- Evaluate performance of advanced AKM24 solvent that doubles the CO₂ adsorption capacity relative to previously tested carbonate solvents.
- Complete 6-month demonstration with bench-scale test unit at the National Carbon Capture Center (NCCC) using coal combustion flue gas.
- Perform techno-economic assessment and engineering study to demonstrate viability of the new technology, targeting at least 30 percent reduction in cost of CO₂ capture.

technical content

Akermin is developing a low-energy, enzyme-catalyzed solvent system for CO₂ capture and testing in a bench-scale unit to continue advancing the technology that was previously developed under project DE-FE0004228. The novel system combines the next-generation BDS and a non-volatile salt solution (AKM24 “solvent”). Updates to an existing 30 Normal cubic meter per hour (30 Nm³/hr) bench-scale test unit will incorporate the process and solvent advances toward demonstrating the effectiveness of the capture system to achieve the DOE target of 90 percent carbon capture at \$40/tonne CO₂. The process scheme is shown in Figure 1.

technology maturity:

Bench-Scale, Actual Flue Gas

project focus:

Carbonic Anhydrase Catalyzed Advanced Carbonate & Non-Volatile Salt Solution (“Solvents”)

participant:

Akermin, Inc.

project number:

FE0012862, FE0004228

NETL project manager:

Andrew Jones
andrew.jones@netl.doe.gov

principal investigator:

John Reardon
Akermin, Inc.
reardonj@akermin.com

co-PI:

Tracy Bucholz
Akermin, Inc.
bucholzt@akermin.com

partners:

WorleyParsons,
Battelle Memorial
Institute,
Pacific Northwest
National Laboratory

performance period:

10/1/10 – 9/30/16

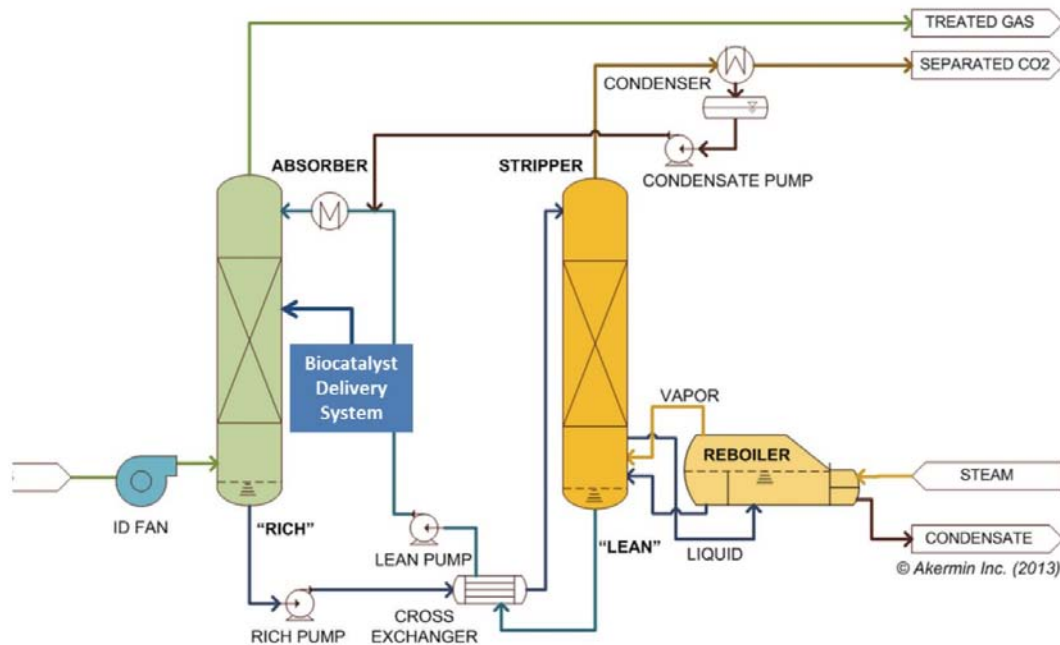

Figure 1: Akermin's CO₂ Capture Process

The technology uses a next-generation BDS, in which, the CA enzyme is immobilized within proprietary polymeric microparticles. CA accelerates hydration of CO₂ to bicarbonate to enhance the performance of the solvent for CO₂ capture. The microparticles have high surface area to enable higher mass transfer rates and provide a protective environment for the enzymes against inactivation by temperature, solvent and shear forces. The catalyst can be delivered by two potential concepts: (1) by recirculation in the absorber only, which requires particle separation, or (2) by continuous circulation in the absorber and stripper, which would require lower temperature stripping to avoid denaturation of the enzyme-based biocatalyst. By incorporating the non-volatile salt solution that has significantly lower regeneration energy combined with using lower temperature steam from the power plant, the result is significant reductions in parasitic power requirements and also lower capital costs for the power plant and integrated CO₂ capture system. Since AKM24 operates with higher CO₂ loading capacity, lower circulation rates can be realized. The modified bench-unit will be operated with actual coal-derived flue gas at the NCCC to validate process modeling performance estimates. Results of process modeling and field testing are used to develop a techno-economic assessment (TEA) to quantify the reduction in costs of CO₂ capture and cost of electricity for a power plant incorporating this technology.

The solvent and process parameters identified to date are provided in Table 1.

TABLE 1: PROCESS PARAMETERS FOR AKERMIN SOLVENT

	Units	Current R&D Value	Target R&D Value
Pure Solvent			
Molecular Weight	mol ⁻¹	Not Disclosed	Not Disclosed
Normal Boiling Point	°C	107	107
Normal Freezing Point	°C	-8	-8
Vapor Pressure at 15 °C	bar	Non-volatile	Non-volatile
Manufacturing Cost for Solvent	\$/kg	Not Disclosed	Not Disclosed
Working Solution			
Concentration	kg/kg	Not Disclosed	Not Disclosed
Specific Gravity (15 °C/15 °C)	—	1.18	1.18
Specific Heat Capacity at STP	kJ/kg-K	3.33	3.33
Viscosity at STP	cP	3.98	3.98

TABLE 1: PROCESS PARAMETERS FOR AKERMIN SOLVENT

	Units	Current R&D Value	Target R&D Value
Absorption			
Pressure	bar	1.07	1.07
Temperature	°C	50	50
CO ₂ Loading (Rich Loading)	mol/mol	0.80	0.80
Heat of Absorption	kJ/mol CO ₂	52	52
Solution Viscosity	cP	2.01	2.01
Desorption			
Pressure	bar	1.07	1.07
Temperature	°C	107	107
CO ₂ Loading (Lean Loading)	mol/mol	0.40	0.40
Heat of Desorption (Estimated from Abs. Equilibria)	kJ/mol CO ₂	70	70
Proposed Module Design		<i>(for equipment developers)</i>	
Flue Gas Flowrate	kg/hr	40	
CO ₂ Recovery, Purity, and Pressure	%/%/bar	90% / >99% / 1.05	
Absorber Pressure Drop	bar	<0.02	

Definitions:

STP – Standard Temperature and Pressure (15 °C, 1 atm).

Pure Solvent – Chemical agent(s), working alone or as a component of a working solution, responsible for enhanced CO₂ absorption (e.g., the amine MEA in an aqueous solution).

Manufacturing Cost for Solvent – “Current” is market price of chemical, if applicable; “Target” is estimated manufacturing cost for new solvents, or the estimated cost of bulk manufacturing for existing solvents.

Working Solution – The solute-free (i.e., CO₂-free) liquid solution used as the working solvent in the absorption/desorption process (e.g., the liquid mixture of MEA and water).

Absorption – The conditions of interest for absorption are those that prevail at maximum solvent loading, which typically occurs at the bottom of the absorption column. Measured data at other conditions are preferable to estimated data.

Desorption – The conditions of interest for desorption are those that prevail at minimum solvent loading, which typically occurs at the bottom of the desorption column. Operating pressure and temperature for the desorber/stripper are process-dependent. Measured data at other conditions are preferable to estimated data.

Pressure – The total pressure. If the vapor phase is pure CO₂, this is the total pressure; if it is a mixture of gases, this is the sum of partial pressures for each of the vapor components. Note that for a typical PC power plant, the total pressure of the flue gas is about 1 atm and the concentration of CO₂ is about 13.2 percent on a wet basis. Therefore, the partial pressure of CO₂ is roughly 0.132 atm or 0.130 bar at the given saturation temperature conditions.

Concentration – Mass fraction of pure solvent in working solution.

Loading – The basis for CO₂ loadings is moles of pure solvent.

Other Parameter Descriptions:

Chemical/Physical Solvent Mechanism – The reaction of CO₂ with water (H₂O) in the presence of CA and base (B) is as follows:

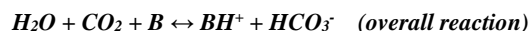

The presence of CA increases the rate of conversion of CO₂ to bicarbonate (improving the slow step above), but does not affect the equilibrium properties of the solvent. The rate of hydration of CO₂ (i.e., the reaction with H₂O) in the absence of the enzyme is exceedingly slow; however, the enzyme provides dramatic acceleration of the reaction ($k_{\text{cat}} \approx 1/\text{microsecond}$) and is limited only by diffusion.

Solvent Contaminant Resistance – Studies with K₂CO₃ and CA in solution indicate that the enzyme is not inhibited by sulfate, sulfite, nitrite, nitrate, or chloride ions in solution at levels expected for coal flue gas. Divalent metal ions (e.g., mercury [Hg²⁺], lead [Pb²⁺]) inhibit the activity of soluble CA, because the active site in the enzyme itself contains a divalent metal ion (mainly zinc). However, the low solubility of their hydroxide and carbonate salts in carbonate solutions and the stabilizing role of the immobilization system alleviate some of the decrease in CA activity.

Solvent Foaming Tendency – The presence of soluble enzyme can contribute to foaming, especially in the stripper, whereas the tendency to foam is mitigated by using immobilized enzyme. Previous work has used small quantities of anti-foam.

Flue Gas Pretreatment Requirements – Standard SO_x, NO_x and mercury control systems that meet local air emission requirements will be sufficient.

Solvent Makeup Requirements – The capture of acid gases, such as sulfur dioxide (SO₂) and nitrogen dioxide (NO₂), will reduce carrying capacity over time. Initial tests indicated the loss of capacity to be on the order of 2 percent per year or less. K₂CO₃ is non-volatile and has excellent oxidative stability (an inorganic salt solution). Akermin's new solvent (AKM24) is based on a non-volatile salt solution; therefore, it is expected to have similar benefits.

Waste Streams Generated – In the first-generation technology, the deactivated packing would need to be replaced (recycled) to maintain CA activity on an ongoing basis. Notably, the second-generation BDS provides for on-stream biocatalyst maintenance as a microparticle, which reduces the volume and cost of solid waste management.

Process Design Concept – Figure 1 presents the basic process flow sheet.

Proposed Module Design – Unless noted, flue gas feed pressure is 14.7 psia, temperature is 135 °F (before flue gas cooler), and composition leaving the flue gas desulfurization (FGD) unit (wet basis) should be assumed:

Composition (% vol)					Composition (ppmv)	
CO ₂	H ₂ O	N ₂	O ₂	Ar	SO _x	NO _x
13.17	17.25	66.44	2.34	0.80	42	74

technology advantages

- Advanced solvent in the presence of Akermin's BDS has high CO₂ absorption rates and higher capacity relative to first generation. It also has significantly lower regeneration energy compared to amine-based solvents.
- Solvent is non-volatile, oxidative stable, and environmentally benign.
- Advanced solvent uses lower-grade steam with lower regeneration temperatures than amine solvents; resulting in lower auxiliary power requirements, more power generated, lower unit capital costs, and lower CO₂ capture costs.

R&D challenges

- Scale up and manufacturing of the immobilized biocatalyst batches that consistently achieve the critical performance metrics (cost, efficiency, ease of integration with BDS, etc.).
- Optimize the BDS production process to minimize leachables to mitigate risk of foaming. Demonstrating an effective BDS in the lab- and bench-scale test units to achieve stable and consistent long-term performance.

results to date/accomplishments

- Demonstrated a 22x improvement in the overall mass transfer with microparticle-immobilized enzyme in a counter-current, packed-column reactor, suggesting good potential to lower absorber heights and reduce capital costs.
- Demonstrated seven-fold (7x) reduction in space time at 90 percent capture with biocatalyst-coated packing compared to blank.
- Achieved 90 percent capture using K_2CO_3 solution at approximately $20 \text{ Nm}^3/\text{hr}$ gas flow rate.
- Demonstrated 2,800 hours online with an estimated half-life in the range of 500 days.
- Verified negligible heat-stable salts accumulation (<2 percent loss of capacity per year).
- Demonstrated high-purity CO_2 product (>99.9 percent pure CO_2 , dry basis).
- Confirmed near zero aerosol formation (NCCC measurements using isokinetic sampling showed salt carryover was below their 0.8 ppm lower detection limit).
- Demonstrated biocatalyst production with six replicate batches scaled up to show consistency of scalable second-generation production process.
- Process modeling with new AKM24 solvent showed conditions where regeneration energy is less than 2.4 GJ/t CO_2 with total equivalent work less than 220 kWh/t CO_2

next steps

- Complete long-term performance testing of the BDS in the lab-scale CLR.
- Complete scale up of the BDS manufacturing process.
- Complete design and engineering plans for modifying the existing bench-scale test unit to accommodate the next-generation BDS and advanced AKM24 solvent.
- Perform testing at the NCCC and update the TEA.

available reports/technical papers/presentations

12th Greenhouse Gas Control Technologies (GHGT-12) Conference Presentation, October 2014. http://www.netl.doe.gov/FileLibrary/Research/Coal/carbon_capture/post-combustion/FE0012862-GHGT-12-Presentation-10-07-14.pdf.

“Novel Flow Sheet for Low Energy CO_2 Capture Enabled by Biocatalyst Delivery System,” presented by John Reardon, Akermin Inc., 2014 NETL CO_2 Capture Technology Meeting, Pittsburgh, PA, July 2014. [http://www.netl.doe.gov/FileLibrary/Events/2014/2014 NETL \$CO_2\$ Capture/J-Reardon-Akermin-Novel-Flow-Sheet-For-Low-Energy- \$CO_2\$ -Capture.pdf](http://www.netl.doe.gov/FileLibrary/Events/2014/2014%20NETL%20CO2%20Capture/J-Reardon-Akermin-Novel-Flow-Sheet-For-Low-Energy-CO2-Capture.pdf).

Novel Flow Sheet for Low Energy CO_2 Capture Enabled by Biocatalyst Delivery System,” Project Kick-Off Meeting Presentation, November 22, 2013. <http://www.netl.doe.gov/FileLibrary/Research/Coal/ewr/CO2/FE0012862-Kick-Off-Meeting-Presentation-11-22-13.pdf>.

Zaks, Alex, and Reardon, J., Final Report, “Advanced Low Energy Enzyme Catalyzed Solvent for CO_2 Capture,” 2013. <http://www.osti.gov/scitech/servlets/purl/1121752>.

“Advanced Low Energy Enzyme Catalyzed Solvent for CO_2 Capture,” Final Project Review Presentation, November 2013. <http://www.netl.doe.gov/File%20Library/Research/Coal/carbon%20capture/post-combustion/FE0004228-Akermin-Close-Out-Mtg-Presentation-11-22-13.pdf>.

“Advanced Low Energy Enzyme Catalyzed Solvent for CO₂ Capture,” 2013 NETL Annual CO₂ Capture Technology Meeting, Pittsburgh, PA, July 2013. <http://www.netl.doe.gov/File%20Library/Events/2013/CO2%20Capture/J-Reardon-Akermin-Enzyme-Catalyzed-Solvent-for-CO2.pdf>

“Enzyme-Catalyzed Process for Low-Cost CO₂ Separation and Capture,” 2012 MEGA Conference, Baltimore, MD, August, 2012. <http://www.netl.doe.gov/File%20Library/Research/Coal/ewr/CO2/enzyme-catalyzed-process-aug2012.pdf>.

“Advanced Enzyme-Catalyzed CO₂ Capture in Low-Energy Solvents,” NETL Annual CO₂ Capture Technology Meeting, July, 2012, Pittsburgh, PA. <http://www.netl.doe.gov/File%20Library/research/coal/cross-cutting%20research/advanced%20materials/advanced-low-energy-enzyme-catalyzed-solvent-july2012.pdf>.

“Advanced Low Energy Enzyme Catalyzed Solvent for CO₂ Capture,” 2011 NETL Annual CO₂ Capture Technology Meeting, August, 2011, Pittsburgh, PA. <http://www.netl.doe.gov/File%20Library/research/coal/carbon%20capture/23Aug11-Zaks-Akermin-Enzyme-Catalyzed-Solvent.pdf>.

“Advanced Low Energy Enzyme Catalyzed Solvent for CO₂ Capture,” 2010 NETL Annual CO₂ Capture Technology Meeting, September, 2010, Pittsburgh, PA. <http://www.netl.doe.gov/File%20Library/research/coal/carbon%20capture/Paul-Gifford---Akermin-Inc.pdf>.

APPLICATION OF A HEAT-INTEGRATED POST-COMBUSTION CO₂ CAPTURE SYSTEM WITH HITACHI ADVANCED SOLVENT INTO EXISTING COAL-FIRED POWER PLANT

primary project goals

The University of Kentucky is using an innovative heat-integration method that would utilize waste heat from a carbon capture system using the MHPSA (Mitsubishi Hitachi Power Systems America) advanced solvent while improving steam turbine efficiency. The proposed process also implements a process concept (working with the heat integration method) that increases solvent capacity and capture rate in the carbon dioxide (CO₂) scrubber.

Develop a process using a two-stage stripping concept combined with an innovative heat integration method that utilizes waste heat to reduce costs through use of an improved power plant cooling tower by testing the process in a 0.7-MWe slipstream pilot-scale system.

technical goals

- Demonstrate the University of Kentucky Center for Applied Energy Research (UK-CAER) high-efficiency heat-integrated process.
- Demonstrate the UK-CAER process using the MHPSA advanced solvent.
- Gather data on solvent degradation and water management.
- Gather data on material corrosion and identify appropriate materials for a scaleup plant.

technical content

The objective of this project is to pilot-test a novel heat-integration scheme utilizing waste heat from the CO₂ capture system (CCS) to improve the plant and CCS system efficiency, which will meet the U.S. Department of Energy (DOE) performance and cost targets of 90 percent CO₂ capture, 95 percent CO₂ purity, and an increase in the cost of electricity (COE) of no more than 35 percent. To achieve this, the proposed capture system uses a two-stage stripper configuration where the second stage is designed as an air stripper to reduce the carbon loading in the lean solvent with CO₂-laden air feeding into the boiler as combustion air and an optimized two-stage cooling tower concept to reduce the condenser temperature, thereby improving the turbine efficiency. The project will also involve determining the performance of monoethanolamine (MEA) and the MHPSA advanced solvent in the proposed capture system, identify appropriate materials and solvent pollution control technologies necessary for a 550-MW commercial-scale carbon capture plant, demonstrate the capability of integrating waste heat from the carbon capture platform with the balance-of-plant to improve the overall plant efficiency, and collect the necessary information/data to provide a full techno-economic and environmental health and safety (EH&S) analysis.

technology maturity:

Pilot-Scale, Actual Flue Gas Slipstream

project focus:

Slipstream Demonstration Using the MHPSA Advanced Solvent

participant:

University of Kentucky

project number:

FE0007395

NETL project manager:

José Figueroa
jose.figueroa@netl.doe.gov

principal investigator:

Kunlei Liu
University of Kentucky
kunlei.liu@uky.edu

partners:

Mitsubishi Hitachi Power Systems America (MHPSA), Electric Power Research Institute (EPRI), Smith Management Group

performance period:

10/1/11 – 9/30/16

The project will involve the design, fabrication, installation, testing, and analyses of a slipstream facility located at LKE's E.W. Brown Generating Station to demonstrate an innovative carbon capture system that utilizes heat integration with the main power plant. The design, start-up, and baseline of the pilot system will be performed with a generic 30 wt% MEA solvent to obtain data for direct comparison with the National Energy Technology Laboratory (NETL) reference case. In addition, MHPSA's proprietary solvent H3-1 will be tested upon completion of the MEA baseline testing. Parametric test campaigns, system transient dynamic studies, and long-term continuous verification tests of the heat-integration process and for each of the solvents will be conducted. The series of transient tests will quantify the ability of the carbon capture system to follow load demand, flue gas conditions, and individual component operation. Concurrent with the continuous verification runs, corrosion evaluation and solvent degradation (liquid and gaseous emissions) studies will be conducted. The potential heat integration, solvent and water management, and CO₂ capture system stability and operability will be the main focus points.

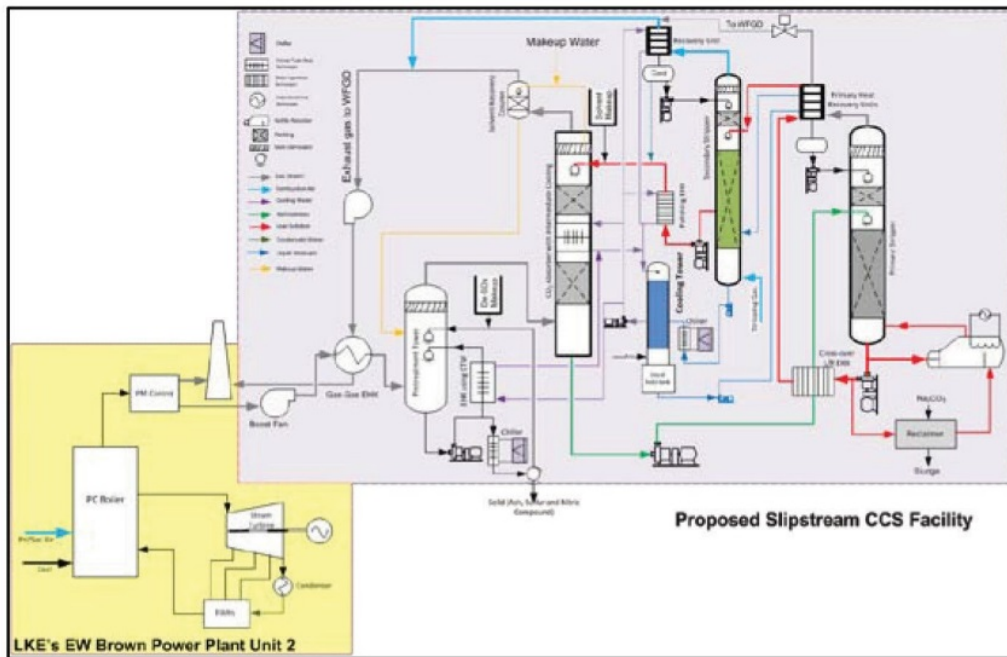

Figure 1: Proposed Slipstream Carbon Capture System

TABLE 1: PROCESS PARAMETERS FOR MEA CASE

	Units	Current R&D Value	Target R&D Value
Pure Solvent			
Molecular Weight	mol ⁻¹	—	<120g
Normal Boiling Point	°C	169	
Normal Freezing Point	°C	-8.8	
Vapor Pressure at 15 °C	bar	—	
Manufacturing Cost for Solvent	\$/kg	confidential	0.5x10 ⁻³
Working Solution			
Concentration	kg/kg	0.45/1.0	
Specific Gravity (15 °C/15 °C)	—	0.98 at 25°C	
Specific Heat Capacity at STP	kJ/kg-K	0.92 at 40°C	
Viscosity at STP	cP	7.0 at 25°C	
Absorption			
Pressure	bar	≈1	≈1
Temperature	°C	40-50	30-40
Equilibrium CO ₂ Loading	mol/mol	0.46	0.5
Heat of Absorption	kJ/mol CO ₂	75.4	<75.4
Solution Viscosity	cP	7.7	7.7
Desorption			
Pressure	bar	≈2	3
Temperature	°C	110-120	125
Equilibrium CO ₂ Loading	mol/mol	0.11	0.1
Heat of Desorption	kJ/mol CO ₂	75.4	75.4

Note: MHPSA (H3-1) has confidential solvent information, therefore not shown herein.

Definitions:

STP – Standard Temperature and Pressure (15 °C, 1 atm).

Pure Solvent – Chemical agent(s), working alone or as a component of a working solution, responsible for enhanced CO₂ absorption (e.g., the amine MEA in an aqueous solution).

Manufacturing Cost for Solvent – “Current” is market price of chemical, if applicable; “Target” is estimated manufacturing cost for new solvents, or the estimated cost of bulk manufacturing for existing solvents.

Working Solution – The solute-free (i.e., CO₂-free) liquid solution used as the working solvent in the absorption/desorption process (e.g., the liquid mixture of MEA and water).

Absorption – The conditions of interest for absorption are those that prevail at maximum solvent loading, which typically occurs at the bottom of the absorption column. These may be assumed to be 1 atm total flue-gas pressure (corresponding to a CO₂ partial pressure of 0.13 bar) and 40 °C; however, measured data at other conditions are preferable to estimated data.

Desorption – The conditions of interest for desorption are those that prevail at minimum solvent loading, which typically occurs at the bottom of the desorption column. Operating pressure and temperature for the desorber/stripper are process-dependent (e.g., an MEA-based absorption system has a typical CO₂ partial pressure of 1.8 bar and a reboiler temperature of 120 °C). Measured data at other conditions are preferable to estimated data.

Pressure – The pressure of CO₂ in equilibrium with the solution. If the vapor phase is pure CO₂, this is the total pressure; if it is a mixture of gases, this is the partial pressure of CO₂. Note that for a typical PC power plant, the total pressure of the flue gas is about 1 atm and the concentration of CO₂ is about 13.2 percent. Therefore, the partial pressure of CO₂ is roughly 0.132 atm or 0.130 bar.

Concentration – Mass fraction of pure solvent in working solution.

Loading – The basis for CO₂ loadings is moles of pure solvent.

Other Parameter Descriptions:

Chemical Solvent Mechanism – The absorption reactions for the amine-based CO₂ capture system can be broken into two reactions, as given below. The absorption of CO₂ by primary and secondary amines (SC1) is mainly dictated by the formation of carbamates. The reaction of CO₂ with tertiary amines (SC2) results in the formation of a bicarbonate.

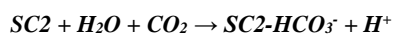

In the stripper, the reverse reactions occur with energy input to drive the endothermic reaction and produce free CO₂.

The reaction rate constant for primary and secondary amine species can vary, but is generally on the order of 10³. The reaction with tertiary amines to directly form bicarbonate is much slower (10x less). A third possible reaction to form bicarbonate directly from hydroxide present in solution can generally be excluded from consideration despite the fast rate constant (10⁴) because the hydroxide concentration is limited by the base dissociation constant in 30 wt% MEA (<1 x 10⁻⁴).

The heat of desorption (dictated by chemical bond enthalpy, gas dissolution, and non-ideal mixing) represents a large portion of the energy input required to drive the endothermic reaction and produce free CO₂ in the stripper. Considering only the chemical reaction component (bulk contribution at stripping conditions), the lowest energy solvent is represented by the bicarbonate reaction (27 kJ/mol), while the carbamate reaction is much higher at approximately 60–70 kJ/mol. The MHPSA advanced solvent is optimized to minimize heat of regeneration, yielding an overall energy requirement that is approximately 36 percent lower than a baseline MEA solvent for a conventional process.

The rate of CO₂ capture is a function of the overall mass transfer coefficient, interfacial area, and the mean difference in concentration of CO₂ in the flue gas and amine solvent phases. The rate is enhanced if the driving force (mean flue gas CO₂ concentration—mean CO₂ concentration in solvent) is also increased. The size of absorber needed to capture a given quantity of CO₂ is reduced because the solvent has higher rates of CO₂ capture compared to MEA (mass transfer coefficient), and also due to the larger concentration gradient due to the air stripping process enhancements.

Solvent Contaminant Resistance – Exposure to sulfur dioxide (SO₂), halogen, nitrogen oxide (NO_x), and trace metals that are present in the feed flue gas stream can cause the solvent to degrade with time.

Solvent Foaming Tendency – The MHPSA solvent has a low tendency for foaming in the scrubber.

Flue Gas Pretreatment Requirements – After passing through the power plant's SO₂ scrubber, flue gas enters a direct water contactor to reduce the CO₂ absorber operating temperature and remove excess water. Following this, the flue gas enters a counter-flow, pre-treatment tower using a dilute caustic solution for the removal of the final SO₂ and other gaseous contaminants before entering the CO₂ scrubber.

Solvent Makeup Requirements – Compared to 30 wt% MEA, the MHPSA solvent has low degradation rate and requires approximately 15 percent of MEA makeup rate.

Waste Streams Generated – Solid waste (ash, sulfur, and nitric compounds) generated after the flue gas pre-treatment tower and sludge waste from the amine reclaimer will be removed.

Process Design Concept – As presented in the flow sheet/block flow diagram.

Proposed Module Design – Unless noted, flue gas feed pressure is 14.7 psia, temperature is 135 °F, and composition leaving the flue gas desulfurization (FGD) unit (wet basis) should be assumed:

Composition (% vol)					Composition (ppmv)	
CO ₂	H ₂ O	N ₂	O ₂	Ar	SO _x	NO _x
13.17	17.25	66.44	2.34	0.80	42	74

technology advantages

- The two-stage stripping unit, including the deployment of an air-based secondary stripper, will regenerate an exceptionally CO₂-lean solvent, increasing the rate of CO₂ absorption.
- Cooling water temperature with the heat-integrated cooling tower can be decreased by more than 2 °C compared to conventional evaporative cooling towers, leading to improved steam turbine and power plant efficiency and lower levelized cost-of-electricity (LCOE).
- The solvent recovery column at the outlet of the gas stream leaving the CO₂ absorber uses water from the in-duct cooler to neutralize and recover solvent vapor in this stream.
- The primary CO₂ stripper can be operated at approximately 3 bars in order to maximize the energy benefit while minimizing system capital and solvent degradation, which could lead to low compressor capital and operating costs.
- The H3-1 advanced solvent used in this system has (1) a higher mass-transfer flux, (2) a higher net cycle carbon capacity, (3) less energy demand for CO₂ stripping, and (4) lower corrosion rates than a 30 wt% MEA solution.
- H3-1 is also less corrosive than MEA and has 89 percent lower thermal and oxidative degradation rates compared to MEA, leading to low capital costs and low solvent makeup costs.

R&D challenges

- Solvent air stripping has been demonstrated at the bench scale, but will need to be demonstrated at the slipstream scale.
- The application of a liquid desiccant for the integrated cooling system has been demonstrated for HVAC applications, but will need to be demonstrated for this application.
- Solvent oxidation in the air stripper due to high oxygen content (approximately 12 percent) must be determined.

results to date/accomplishments

- Results from a preliminary techno-economic analysis indicated significant reduction (≈ 56 percent) in the incremental LCOE over a subcritical power plant without CO₂ capture versus 80 percent incremental LCOE for a plant with MEA CO₂ capture system.
- Compared to the case 10 of the bituminous coal baseline using the conventional Fluor Econamine FG+ technology using MEA as the solvent, the capital costs of the coal power plant using the UK-CAER technology with the MEA solvent were lowered by 10 percent. Compared to the UK-CAER/MEA case, the capital costs of the plant with the UK-CAER/H3-1 technology were further lowered by 6.7 percent.
- It was estimated from process modeling that the UK-CAER solvent requires ≈ 36.8 percent lower thermal energy for regeneration compared to the DOE/NETL reference case 10.
- Laboratory corrosion tests indicated that H3-1 had a lower corrosion rate compared to MEA, and so lower-cost materials of construction (carbon steel) could be used instead of stainless steel, lowering the plant capital costs.
- A preliminary EH&S assessment indicated minimal or insignificant levels of emissions of solvent degradation byproducts, as well as total air emissions from the proposed 0.7 MWe pilot at the E.W.Brown station.
- 0.7-MWe slipstream pilot start-up and commissioning completed at the E.W.Brown generating station

next steps

- The MEA long term test campaign, with 2,000 hours of load-following run with 30 wt% MEA, to be conducted.
- The H3-1 long term test campaign, with 2,500 hours of load-following run also to be conducted.
- Parametric pilot-scale tests using 30 w/w percent MEA to be completed in FY15 4th quarter.
- Finalize technical/economic analysis and EH&S assessment.

available reports/technical papers/presentations

Liu, K. et. al., “Nitrosamines and Thermal Degradation: Exploring Solvent Degradation with Mass Spectrometry,” UT Review Meeting, October 2014. <http://www.netl.doe.gov/File%20Library/Research/Coal/carbon%20capture/post-combustion/UT-Review-DOE-UKy-10-23-14.pdf>.

Nikolic, H., and Thompson, J., “Application of a Heat Integrated Post-Combustion CO₂ Capture System with Hitachi Advanced Solvent into Existing Coal-Fired Power Plants,” 2014 NETL CO₂ Capture Technology Meeting, Pittsburgh, PA, July 2014. <http://www.netl.doe.gov/File%20Library/Events/2014/2014%20NETL%20CO2%20Capture/H-Nikolic-CAER-UK-Heat-Integrated-Post-Combustion-CO2.pdf>.

Liu, K., “Application of a Heat Integrated Post-Combustion CO₂ Capture System,” 2013 NETL CO₂ Capture Technology Meeting, Pittsburgh, PA, July 2013. <http://www.netl.doe.gov/File%20Library/Events/2013/CO2%20Capture/K-Liu-UKCAER-Heat-Integrated-Post-Combustion-CO2.pdf>.

Neathery, J., “Slipstream Demonstration of a Heat Integrated CO₂ Capture System,” 2012 NETL CO₂ Capture Technology Meeting, Pittsburgh, PA, July 2012. <http://www.netl.doe.gov/File%20Library/research/coal/carbon%20capture/post-combustion/slipstream-demonstration-heat-integrated-july2012.pdf>.

Liu, K., et al., “Application of A Heat-Integrated Post-Combustion CO₂ Capture System with Hitachi Advanced Solvent into Existing Coal-Fired Power Plant,” Project Kick-Off Meeting Presentation, October 2011. <http://www.netl.doe.gov/File%20Library/Research/Coal/ewr/cO2/application-heat-integrated-oct2011.pdf>.

SLIPSTREAM PILOT-SCALE DEMONSTRATION OF A NOVEL AMINE- BASED POST-COMBUSTION PROCESS TECHNOLOGY FOR CO₂ CAPTURE FROM COAL-FIRED POWER PLANT FLUE GAS

primary project goals

Linde is refining a post-combustion capture technology incorporating BASF's novel amine-based process to reduce regeneration energy requirements by designing, building, and operating a 1-MWe equivalent slipstream pilot plant at the National Carbon Capture Center (NCCC).

technical goals

- Complete techno-economic assessment of a 550-MWe power plant integrated with the Linde-BASF post-combustion capture plant incorporating BASF's OASE® blue aqueous amine-based solvent to illustrate the benefits.
- Develop and optimize a basic design package for a 1-MWe equivalent pilot plant.
- Build and operate the 1-MWe pilot plant at a coal-fired power plant host site providing the flue gas as a slipstream.
- Implement parametric tests to demonstrate the achievement of target performance using data analysis.
- Implement long duration testing to demonstrate solvent stability and obtain critical data for scaleup.

technical content

Linde and partners are designing, building, and operating a 1-MWe pilot plant at NCCC. The technology aims to reduce the regeneration energy requirements using novel solvents that are stable under coal-fired power plant feed gas conditions. BASF's OASE® blue technology has been developed to address the key drawbacks in the large-scale application of monoethanolamine (MEA) for flue gas carbon capture, including: (1) high specific energy for regeneration, (2) lack of stability toward thermal and oxidative degradation, (3) increased corrosiveness with increased carbon dioxide (CO₂) loading, and (4) lack of tolerance to impurities from coal combustion products. The specific proprietary solvent has been selected by: (1) screening approximately 400 chemical substances using vapor-liquid equilibrium measurements to determine approximate cyclic capacities, (2) laboratory measurements of the key thermodynamic and kinetic properties of the 70 screened candidates and their mixtures to identify approximately 15 targets, (3) testing of the targets to determine optimum circulation rate and specific energy consumption in a laboratory-scale mini-plant to identify the leading candidates, and (4) pilot testing of three candidates

technology maturity:

Pilot-Scale, Actual Flue Gas Slipstream

project focus:

Slipstream Novel Amine-Based Post-Combustion Process

participant:

Linde

project number:

FE0007453

NETL project manager:

Andrew Jones
andrew.jones@netl.doe.gov

principal investigator:

Krish Krishnamurthy
Linde
krish.krishnamurthy@linde.com

partners:

BASF, Linde Engineering Dresden GmbH, Linde Engineering North America, Inc., EPRI

performance period:

12/1/11 – 8/31/16

with real power plant flue gas to identify the optimum solvent for the flue gas application. The CO₂ regeneration from the solvent is carried out by using low-pressure steam, typically from the power plant steam cycle. Testing using a 0.45-MWe pilot plant utilizing lignite-fired power plant flue gas has shown that the OASE® blue solvent is stable and little degradation was observed over 5,000 hours, whereas the reference MEA solvent started to degrade appreciably under same conditions after 2,000 hours.

Linde’s post-combustion CO₂ capture process using BASF OASE® blue solvent technology has several distinct characteristics. Firstly, the direct-contact cooler, CO₂ absorber, and water wash are integrated into a single column with high-performance structured packing for increased capacity (smaller absorber diameter) and an advanced material of construction to minimize capital costs. Secondly, the absorber also has an inter-stage solvent cooler operating on gravity flow, eliminating the capital and operating expenses of a solvent pump. The flue gas blower is located downstream of the absorber to minimize its size (due to the reduced volume of flue gas handled by the blower). Further, the stripping column can be operated at higher pressures (up to 3.6 atm) than that of a MEA stripper, lowering compression costs. Finally, optional process heat integration allows steam raised by heat exchange with flue gas before the flue gas desulfurization (FGD) unit to be used at an intermediate point in the desorber, and the use of back-pressure steam turbines allows the recovery of part of the energy of the intermediate-pressure (IP), low-pressure (LP) crossover steam.

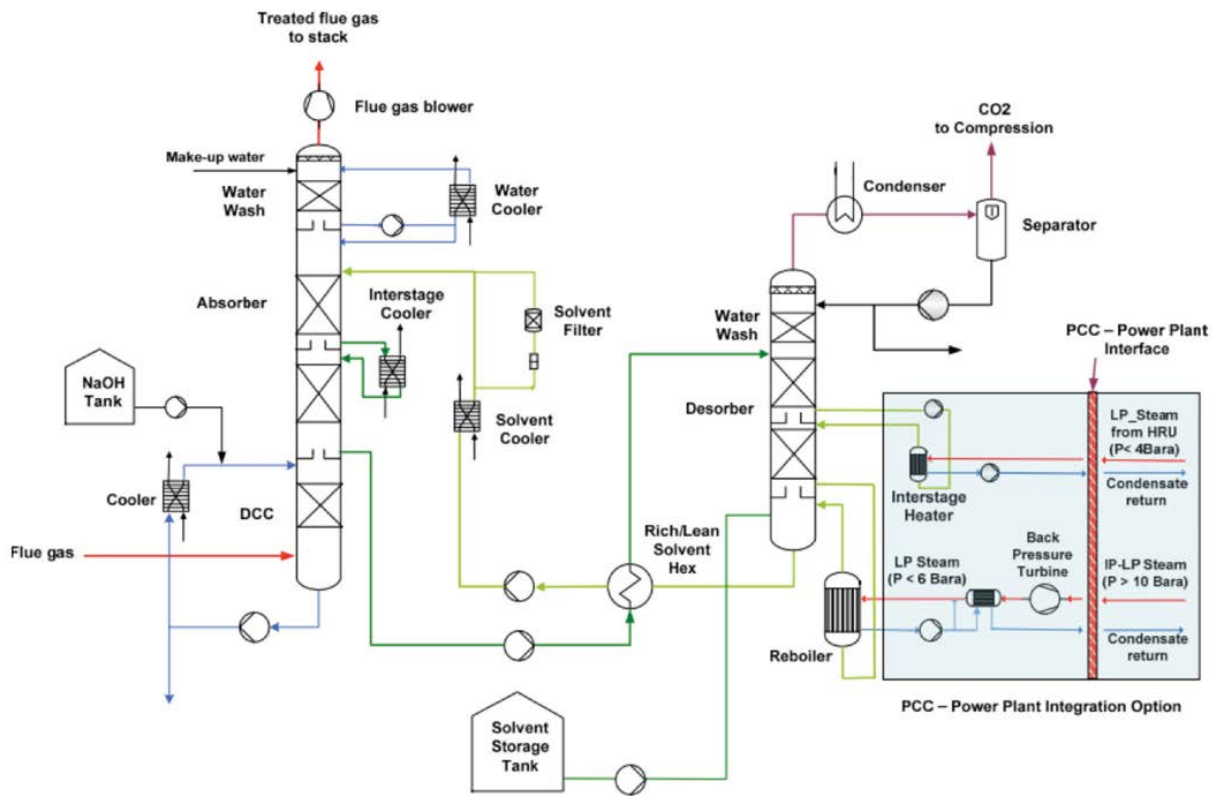

Figure 1: Linde-BASF Post-Combustion Capture Plant

TABLE 1: PROCESS PARAMETERS BASED ON TECHNO-ECONOMIC ASSESSMENT OF A 550-MW PLANT

	Units	Current R&D Value	Target R&D Value
Pure Solvent			
Molecular Weight	mol ⁻¹	proprietary	
Normal Boiling Point	°C	proprietary	
Normal Freezing Point	°C	proprietary	
Vapor Pressure at 15 °C	bar	proprietary	
Manufacturing Cost for Solvent	\$/kg	proprietary	
Working Solution			
Concentration	kg/kg	proprietary	
Specific Gravity (15 °C/15 °C)	—	proprietary	
Specific Heat Capacity at STP	kJ/kg-K	proprietary	
Viscosity at STP	cP	proprietary	
Absorption			
Pressure	bar	≈1 atm	≈1 atm
Temperature	°C	30–70	30–60
Equilibrium CO ₂ Loading	mol/mol	proprietary	
Heat of Absorption	kJ/mol CO ₂	proprietary	
Solution Viscosity	cP	proprietary	
Desorption			
Pressure	bar	1.6–2.5	1.6–3.5
Temperature	°C	See TEA report	
Equilibrium CO ₂ Loading	mol/mol	proprietary	
Heat of Desorption	kJ/mol CO ₂	proprietary	
Proposed Module Design		<i>(for equipment developers)</i>	
Flue Gas Flowrate	kg/hr	See TEA	
CO ₂ Recovery, Purity, and Pressure	%%/bar	90% capture; 99.98% CO ₂ dry basis	
Absorber Pressure Drop	bar	Approximately 100 mbars	

Definitions:

STP – Standard Temperature and Pressure (15°C, 1 atm).

Pure Solvent – Chemical agent(s), working alone or as a component of a working solution, responsible for enhanced CO₂ absorption (e.g., the amine MEA in an aqueous solution).

Manufacturing Cost for Solvent – “Current” is market price of chemical, if applicable; “Target” is estimated manufacturing cost for new solvents, or the estimated cost of bulk manufacturing for existing solvents.

Working Solution – The solute-free (i.e., CO₂-free) liquid solution used as the working solvent in the absorption/desorption process (e.g., the liquid mixture of MEA and water).

Absorption – The conditions of interest for absorption are those that prevail at maximum solvent loading, which typically occurs at the bottom of the absorption column. These may be assumed to be 1 atm total flue-gas pressure (corresponding to a CO₂ partial pressure of 0.13 bar) and 40°C; however, measured data at other conditions are preferable to estimated data.

Desorption – The conditions of interest for desorption are those that prevail at minimum solvent loading, which typically occurs at the bottom of the desorption column. Operating pressure and temperature for the desorber/stripper are process-dependent (e.g., an MEA-based absorption system has a typical CO₂ partial pressure of 1.8 bar and a reboiler temperature of 120°C). Measured data at other conditions are preferable to estimated data.

Pressure – The pressure of CO₂ in equilibrium with the solution. If the vapor phase is pure CO₂, this is the total pressure; if it is a mixture of gases, this is the partial pressure of CO₂. Note that for a typical PC power plant, the total pressure of the flue gas is about 1 atm and the concentration of CO₂ is about 13.2 percent. Therefore, the partial pressure of CO₂ is roughly 0.132 atm or 0.130 bar.

Concentration – Mass fraction of pure solvent in working solution. *Loading* – The basis for CO₂ loadings is moles of pure solvent.

Other Parameter Descriptions:

Flue Gas Pretreatment Requirements – The pretreatment requirement includes reducing sulfur oxide (SO_x) in the flue gas to 2–5 parts per million (ppm) in order to limit solvent degradation and is implemented in a direct contact cooler in conjunction with flue gas cooling, typically by adding appropriate amount of sodium hydroxide corresponding to the SO_x present in the flue gas.

Waste Streams Generated – The main waste liquid stream is from the direct contact cooler where SO_x is removed; this stream is typically handled in the power plant waste water treatment facility. A small amount of solid waste is removed using carbon filters that are replaced at regular intervals. Since the degradation observed in the pilot testing is small, no solvent reclamation unit is envisioned in the large scale.

Process Design Concept – See Figure 1 above.

Proposed Module Design – Unless noted, flue gas feed pressure is 1.014 bara, temperature is 57 °C, and composition leaving the FGD unit (wet basis) should be assumed:

Composition (% vol)					Composition (ppmv)	
CO ₂	H ₂ O	N ₂	O ₂	Ar	SO _x	NO _x
13.17	17.25	66.44	2.34	0.80	42	74

technology advantages

- Significant reduction in regeneration steam consumption (24–40 percent lower), electrical power (25–60 percent lower), and cooling water duty (26 percent lower) compared to a reference MEA plant.
- Higher plant efficiency (29.4 percent higher heating value [HHV]) and lower thermal load compared to a reference MEA plant (24.9 percent) due to a combination of advanced solvent and process improvements, including integrated absorber, downstream gas blower, higher desorber pressure, and inter-stage gravity-flow cooler.
- The total plant costs are ≈17 percent lower compared to a reference MEA plant (≈\$2,400–\$2,435/kW vs. \$2,893/kW for 550 MWnet power plant with MEA CO₂ capture). Lower post-combustion capture plant capital costs (30–35 percent compared to reference MEA at 550 MWe).
- The Linde-BASF technology is readily scalable to large capacities with a single-train system, offering the potential to further reduce costs by utilizing economies of scale.
- BASF is a producer of the solvent in addition to being the technology owner, thereby enabling application at scale by avoiding issues related to solvent manufacturing for large-scale commercial plants.

R&D challenges

- Proving the process enhancements at the 1-MWe plant and at larger scale.
- Validating the basis for scaleup of the advanced process features and the large, single-train capability.

results to date/accomplishments

- Techno-economic assessment of the Linde-BASF OASE® blue process indicated that the cost-of-electricity (COE) only increased by 58–60 percent compared to an 84 percent increase for the reference subcritical pulverized coal plant with 550 MW net-electricity generation.

- The estimated reboiler energy consumption due to the BASF OASE® blue solvent was reduced from 3.55 GJ/T CO₂ to 2.4–2.6 GJ/T CO₂.
- Design basis document completed and 1-MWe pilot plant features selected. Basic design and engineering of the 1-MWe pilot plant completed.
- Detailed 3-D model developed for the 1-MWe pilot plant. Detailed engineering has been completed and technical packages for the equipment, modules, and construction have been developed. These packages have been sent to multiple vendors and cost estimates have been received; cost compilation and preferred vendor selection has been performed.
- National Environmental Policy Act (NEPA) documentation completed. Hazard and operability study (HAZOP) review completed and design updates incorporated.
- Mechanical completion of the 1-MWe pilot plant achieved in July 2014 at NCCC.
- Solvent loading into system completed and initial startup and operations achieved. Initial performance achieved meets performance targets (90 percent capture rate; 99.98 percent CO₂ on a dry basis; up to 1.5 MWe flue gas capacity; <2.8 MJ/tonne CO₂ specific regeneration energy consumption).

next steps

Additional parametric testing for specific energy optimization and emissions minimization will be performed, followed by long duration tests, and target performance will be verified during the course of 1-MW pilot plant testing.

available reports/technical papers/presentations

“12th Greenhouse Gas Control Technologies (GHGT-12) Conference Presentation,” October 2014.

<http://www.netl.doe.gov/File%20Library/Research/Coal/carbon%20capture/post-combustion/141009-GHGT-12-Presentation-Linde-BASF-Final.pdf>.

Krishnamurthy, K., “Slipstream Pilot-Scale Demonstration of a Novel Amine-Based Post-Combustion Process Technology for CO₂ Capture from Coal-Fired Power Plant Flue Gas,” 2014 CO₂ Capture Technology Meeting, Pittsburgh, PA, July 2014.

<http://www.netl.doe.gov/File%20Library/Events/2014/2014%20NETL%20CO2%20Capture/K-Krishnamurthy-Linde-Slipstream-Pilot-Scale-Demonstration.pdf>.

Krishnamurthy, K., “Slipstream Pilot-Scale Demonstration of a Novel Amine-Based Post-Combustion Process Technology for CO₂ Capture from Coal-Fired Power Plant Flue Gas,” 2013 CO₂ Capture Technology Meeting, Pittsburgh, PA.

<http://www.netl.doe.gov/File%20Library/Events/2013/CO2%20Capture/K-Krishnamurthy-Linde-Slipstream-Demo-of-Novel-Amine-Based-P.pdf>.

“Techno-Economic Analysis of 500 MWe Subcritical PC Power Plant with CO₂ Capture,” Topical Report of initial techno-economic analysis, May 2012. <http://www.netl.doe.gov/File%20Library/Research/Coal/ewr/CO2/techno-economic-analysis-topical-rpt-may2012.pdf>.

“Techno-Economic Analysis of 500 MWe Subcritical PC Power Plant with CO₂ Capture,” presentation given at NETL by S. Jovanovic & K. Krishnamurthy, Pittsburgh, PA, May 2012.

<http://www.netl.doe.gov/File%20Library/Research/Coal/ewr/CO2/techno-economic-analysis-topical-presentation-may2012.pdf>.

“Slipstream Pilot-Scale Demonstration of a Novel Amine-Based Post-Combustion Process Technology for CO₂ Capture from Coal-Fired Power Plant Flue Gas,” Project Kick-Off Meeting Presentation, November 2011.

<http://www.netl.doe.gov/File%20Library/Research/Coal/ewr/CO2/slipstream-pilot-scale-demonstration-novel-amine-nov2011.pdf>.

“Slipstream Pilot Plant Demo of a Amine-Based Post-Combustion Capture Technology for CO₂ Capture from Coal-Fired Power Plant Flue Gas,” presented by Krish R. Krishnamurthy, Linde LLC, 2011 Fall Technical Subcommittee Meeting, Pittsburgh, PA, October 31, 2011. <http://www.netl.doe.gov/File%20Library/Research/Coal/ewr/CO2/slipstream-pilot-scale-demonstration-novel-amine-oct2011.pdf>.

Krishnamurthy, K.R., “Slipstream Pilot Plant Demo of an Amine-Based Post-Combustion Capture Technology for CO₂ Capture from a Coal-Fired Power Plant Flue Gas,” presented at the 2012 NETL CO₂ Capture Technology Meeting, July 2012, Pittsburgh, PA.

ACCELERATING THE DEVELOPMENT OF “TRANSFORMATIONAL” SOLVENTS FOR CO₂ SEPARATIONS

primary project goals

PNNL is developing transformational CO₂ capture solvents based on their nonaqueous switchable organic solvents, known as CO₂-binding organic liquids (CO₂BOLs). The project focus is to use computation-aided molecular design to optimize, synthesize, and characterize CO₂BOLs with a CO₂-rich viscosity of less than 50 cP at a cost of less than \$10/kg.

technical goals

- Develop a physical property model to predict the viscosity of CO₂BOL compounds.
- Develop a model to predict thermodynamic properties of CO₂BOL compounds.
- Design and synthesize promising CO₂BOL candidate compounds and compare solvent properties with predicted molecular simulations.
- Synthesize candidates meeting desired cost and viscosity targets for further evaluation to determine how molecular structure impacts solvent system viscosity.
- Update thermodynamic and process models using data from CO₂BOL testing to predict process performance and cost.

technical content

Solvent Platform: PNNL is developing transformational CO₂ capture solvents based on their nonaqueous switchable organic solvents, known as CO₂-binding organic liquids (CO₂BOLs). This project advances the development efforts of the previously funded DOE project DE-FE0007466.

CO₂BOLs are a class of switchable ionic liquids (molecular liquids that become ionic in the presence of CO₂) that have lower specific heat and higher CO₂ working capacities compared to aqueous amines, resulting in potential savings in the sensible heat required to strip CO₂.

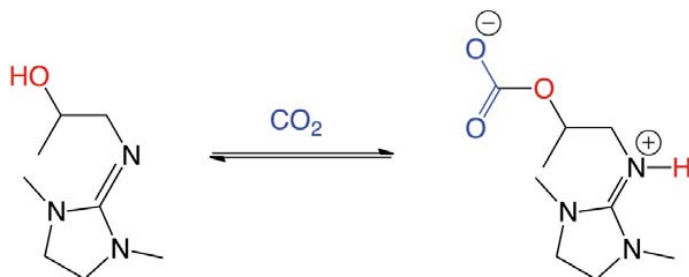

Figure 1: Uptake of CO₂ by Alkanolguanidine BOL (left), and Formation of Zwitterionic CO₂BOL (right)

technology maturity:

Laboratory Scale

project focus:

CO₂-Binding Organic Liquid (CO₂BOL) Solvents

participant:

Pacific Northwest National Laboratory

project number:

FWP-65872, FE0007466

NETL project manager:

Isaac Aurelio

isaac.aurelio@netl.doe.gov

principal investigator:

David Heldebrant

Pacific Northwest

National Laboratory

david.heldebrant@pnnl.gov

partners:

None

performance period:

10/1/11 – 5/31/16

Similar to aqueous amines, CO₂BOLs are basic, but the base (e.g., guanidine, amidine) does not directly react with CO₂. Instead, the alcohol component reacts with CO₂, forming alkyl carbonic acid, and subsequently transfers a proton to the base, forming liquid alkylcarbonate. Current CO₂BOL generation combines the base and the alcohol moieties in a single molecule, lowering volatility (Figure 1).

The addition of a non-polar solvent (anti-solvent) to CO₂BOLs and other switchable solvents during the solvent regeneration destabilizes bound CO₂, thus potentially lowering the temperature at which the stripper can be operated; (this is referred to as the polarity-swing-assisted regeneration [PSAR] process). Preliminary results indicate that PSAR could reduce the regeneration temperatures of CO₂BOLs by more than 20 °C. This allows novel possibilities for heat integration, such as transferring heat from the absorber to the stripper using heat pumps, thereby lowering steam demand for solvent regeneration. The anti-solvent can be separated out from the CO₂BOL by cooling and liquid-liquid phase separation. A schematic of the CO₂BOL-PSAR process is shown in Figure 2.

Previous generations of single-component CO₂BOLs were highly viscous before CO₂ absorption. The current generation of alkanolguanidine CO₂BOLs has lower viscosity before CO₂ absorption.

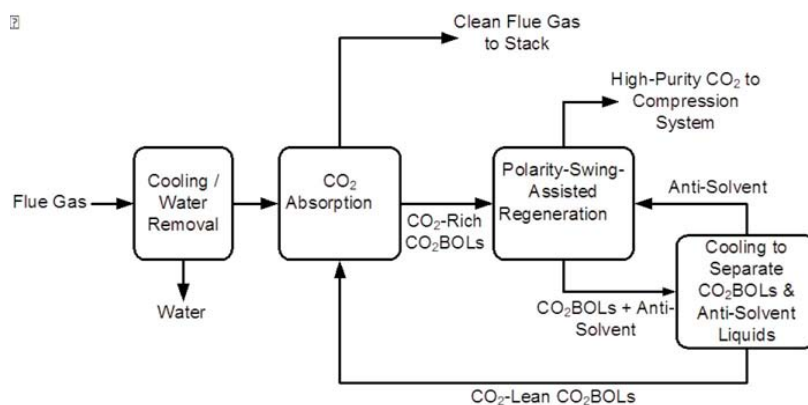

Figure 2: CO₂BOL Absorption and Polarity-Swing-Assisted Regeneration (PSAR) Process

The solvent and process parameters identified to date are provided in Table 1.

TABLE 1: PROCESS PARAMETERS FOR PNNL CO₂BOL SOLVENTS

	Units	Current R&D Value	Target R&D Value
Pure Solvent			
Molecular Weight	mol ⁻¹	171.14	171.14
Normal Boiling Point	°C	262 (decomposes >200)	262 (decomposes >200)
Normal Freezing Point	°C	<0	<0
Vapor Pressure at 15 °C	bar	0.179 (37 °C) (DBU) 0.001 (100 °C)	0.001
Manufacturing Cost for Solvent	\$/kg	\$35	\$10
Working Solution			
Concentration	kg/kg	1 (anhydrous) 0.91 (hydrated)	1 (anhydrous) 0.91 (hydrated)
Specific Gravity (15 °C/15 °C)	—	1.03	1.03
Specific Heat Capacity at STP	kJ/kg-K	1.9	1.9
Viscosity at STP	cP	1.9 (CO ₂ -free solvent) 50 (lean solvent)	1.9 (CO ₂ -free solvent) 11 (lean solvent)

TABLE 1: PROCESS PARAMETERS FOR PNNL CO₂BOL SOLVENTS (CONTINUED)

	Units	Current R&D Value	Target R&D Value
Absorption			
Pressure	bar	1 (near atmospheric, 0.15 bar CO ₂ partial pressure)	1 (near atmospheric, 0.15 bar CO ₂ partial pressure)
Temperature	°C	40	40
Equilibrium CO ₂ Loading	mol/mol	0.5 (at 0.15 bar CO ₂ partial pressure)	0.5 (at 0.15 bar CO ₂ partial pressure)
Heat of Absorption	kJ/mol CO ₂	-80 (anhydrous) -90 (hydrated)	-80 (anhydrous) -90 (hydrated)
Solution Viscosity	cP	356	50
Desorption			
Pressure	bar	2	2
Temperature	°C	103.8	103.8
Equilibrium CO ₂ Loading	mol/mol	0.25 ^c	0.25
Heat of Desorption	kJ/mol CO ₂	-80 (anhydrous) -90 (hydrated)	-80 (anhydrous) -90 (hydrated)
Proposed Module Design		<i>(for equipment developers)</i>	
Flue Gas Flow Rate	kg/hr		
CO ₂ Recovery, Purity, and Pressure	%/%/bar		
Absorber Pressure Drop	bar		

Molecular Design and Optimization

The objective of this project is to expand DOE's Office of Fossil Energy's (FE) capabilities for molecular design and optimization of transformational solvent systems, starting with PNNL's CO₂BOLs solvent platform as a model for this activity. Key program metrics include identification of a viable candidate with a CO₂-loaded viscosity below 50 cP and at a cost no greater than \$10/kg, and also to learn why viscosity increases occur in water-lean solvents and how to minimize viscosity increases. To achieve this, PNNL has developed a novel physical property prediction model that can accurately reproduce laboratory-measured material properties. Previously synthesized and characterized CO₂BOL derivatives from PNNL's completed programs were used to establish the molecular model. A concurrent molecular design effort was started to produce libraries of new compounds with reduced viscosity by introducing design motifs based on organic chemistry principles. Once the molecular model was completed, molecules in the library were simulated to determine which compounds showed reduced viscosity, and, more importantly, why they were less viscous. Modeled compounds are compared against synthesized compounds for validation and refinement (Figure 3). Once design principles were discovered, these new structural motifs were introduced into subsequent molecular designs in order to achieve reductions in rich-solvent viscosity.

To date, the reduced model has been developed with 91 percent accuracy compared to full-scale simulations. The model has identified hydrogen bonding and electrostatic (specifically dipole-dipole between molecules) interactions as the most critical design elements for low-viscosity CO₂BOLs, and from this knowledge we have designed and simulated hundreds of molecules, with tens of candidate molecules that are projected to be less viscous than the previous derivative. The reduced model and the knowledge gained from this study can be used to improve transformational solvent systems across FE's solvent portfolio.

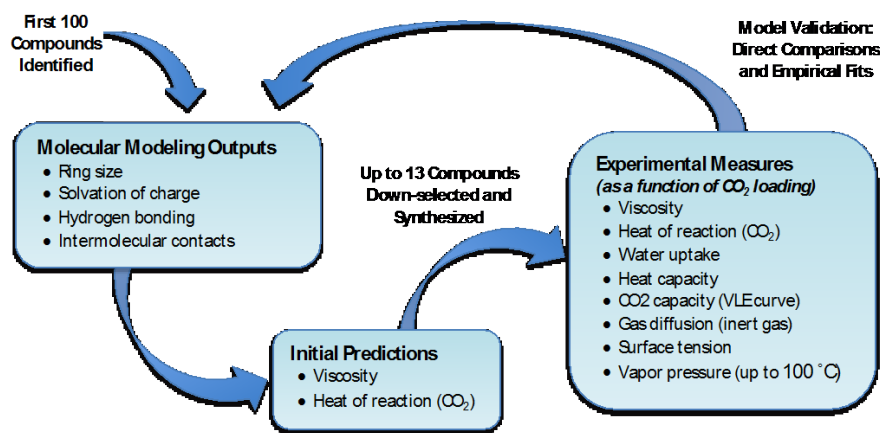

Figure 3. Molecular Modeling Prediction vs. Experimental Measures

Definitions

STP – Standard temperature and pressure (15 °C, 1 atm).

Pure Solvent – Chemical agent(s), working alone or as a component of a working solution, responsible for enhanced CO₂ absorption (e.g., the amine MEA in an aqueous solution).

Manufacturing Cost for Solvent – “Current” is market price of chemical, if applicable; “Target” is estimated manufacturing cost for new solvents, or the estimated cost of bulk manufacturing for existing solvents.

Working Solution – The solute-free (i.e., CO₂-free) liquid solution used as the working solvent in the absorption/desorption process (e.g., the liquid mixture of MEA and water).

Absorption – The conditions of interest for absorption are those that prevail at maximum solvent loading, which typically occurs at the bottom of the absorption column. These may be assumed to be 1 atm total flue-gas pressure (corresponding to a CO₂ partial pressure of 0.13 bar) and 40 °C; however, measured data at other conditions are preferable to estimated data.

Desorption – The conditions of interest for desorption are those that prevail at minimum solvent loading, which typically occurs at the bottom of the desorption column. Operating pressure and temperature for the desorber/stripper are process dependent (e.g., an MEA-based absorption system has a typical CO₂ partial pressure of 1.8 bar and a reboiler temperature of 120 °C). Measured data at other conditions are preferable to estimated data.

Pressure – The pressure of CO₂ in equilibrium with the solution. If the vapor phase is pure CO₂, this is the total pressure; if it is a mixture of gases, this is the partial pressure of CO₂. Note that for a typical PC power plant, the total pressure of the flue gas is about 1 atm and the concentration of CO₂ is about 13.2 percent. Therefore, the partial pressure of CO₂ is roughly 0.132 atm or 0.130 bar.

Concentration – The mass fraction of pure solvent in working solution.

Loading – The basis for CO₂ loadings is moles of pure solvent.

Other Process Parameters

Chemical/Physical Solvent Mechanism – The chemical reaction for the CO₂ capture process with a representative CO₂BOL is shown in Figure 1.

Solvent Contaminant Resistance – Tests of CO₂BOL reactivity with hydrogen chloride (HCl), sulfur oxide (SO_x) and nitrogen oxide (NO_x) will be conducted. In general, CO₂BOLs form heat-stable salts (HSS) with sulfur dioxide (SO₂), NO_x, and HCl. The solvent can be recovered from the HSS using caustic wash or with ion exchange resins. Levels of HSS formation are expected to be similar to that of MEA. Minimal adverse impacts due to arsenic and mercury in the flue gas are expected.

Solvent Foaming Tendency – Foaming tendency has not been observed in prior formulations during bench-scale testing. Foaming of future derivatives remains unknown.

Flue-Gas Pretreatment Requirements – Water management with any of the alkanolguanidine-based CO₂BOLs is different from that with MEA. CO₂BOL solvents are designed to minimize water uptake by the solvent, as the presence of water increases solution viscosity and increases the energy required to regenerate the CO₂BOL. As such, CO₂BOL formulations are favored energetically to run with a 5 wt% steady-state loading of water. To achieve this loading target, the process requires a small refrigeration unit upstream of the absorber to condense out water. Other flue-gas pretreatment requirements (for acid-gas contaminants) are expected to be similar to those with MEA.

Solvent Makeup Requirements – Until a formal lifetime analysis can be made, the estimated makeup rate of CO₂BOLs will depend on the anticipated thermal and chemical degradations. Currently, evaporative losses are projected to be 40 kg per annum.

Waste Streams Generated – CO₂BOLs have lower vapor pressure than MEA, and post-absorber CO₂BOL emissions would be at lower levels (estimated at 0.7 parts per billion [ppb]). Other major waste streams may include stripper wastes and reclaimers wastes.

Proposed Module Design – Unless noted, the following should be assumed for flue gas leaving the FGD (wet basis): feed pressure 1.014 bar, temperature 57 °C, and composition as shown in the table below.

Composition (vol %)					Composition (ppmv)	
CO ₂	H ₂ O	N ₂	O ₂	Ar	SO _x	NO _x
13.17	17.25	66.44	2.34	0.80	42	74

technology advantages

Solvent Platform

- The lower solvent specific heat and water content leads to smaller parasitic load than current solvents (MEA).
- The lower solvent evaporative losses and thermal degradation may lead to lower cost of CO₂ capture.
- The rates of liquid-phase mass-transfer kinetics with CO₂BOLs are comparable to those of current solvents (MEA and piperazine), albeit at higher solution viscosity.
- PSAR may enable low-temperature CO₂BOL regeneration, reducing the pressure of low-pressure steam used for regeneration, thereby increasing net power production and reducing parasitic loads.
- Heat integration possibilities with PSAR and CO₂BOLs may have minimal impact on steam plant cycles, facilitating retrofits for existing plants.

Molecular Design and Optimization

- The current PNNL-developed reduced molecular model can predict solvent thermodynamic and kinetic behavior, providing projections of solution viscosity and heats of reaction. This model enables rapid screening of advanced water-lean solvent platforms for development, as compared to conventional computationally intensive molecular dynamics simulations.
- The PNNL model has identified hydrogen bonding and electronic stacking as the two most critical contributors to viscosity in water-lean solvent platforms such as CO₂BOLs, enabling rapid optimization of solvent chemistry.
- The PNNL model is translatable to other solvent platforms across DOE's portfolio.

R&D challenges

Solvent Platform

- The estimated cost of manufacturing the current-generation CO₂BOL solvent is high, leading to high operation costs.
- Water absorption by the CO₂BOL requires the amount of water in the flue gas to be reduced significantly by refrigeration to avoid water buildup in the solvent recirculation loop. However, these nominal capital costs and auxiliary electric loads are recovered in the net power gains by the PSAR.

Molecular Design and Optimization

- The challenge is to make targets from molecular predictions at a cost of \$10/kg.

results to date/accomplishments

Molecular Design and Optimization

- Silane-based CO₂BOLs, fluorinated CO₂BOLs, and arylfluorinated CO₂BOLs were studied for characterization.
- The impacts of steric interactions, dipole-dipole reductions, and hydrogen bonding were studied, indicating hydrogen bonding and molecular stacking as the largest contributors to viscosity.
- The model to predict viscosities of known compounds was completed and then refined to include hydrogen bond effects within and between molecules. The team observed that intra-molecular hydrogen bonding reduces viscosity while intermolecular bonding increases viscosity.
- Updated the model to predict viscosities of known compounds, and confirmed that predicted viscosities are comparable with engineering and experimental values.
- The reduced model shows 91 percent accuracy of full-scale molecular dynamics simulations at 1/14th of the time scale.
- Modeling of 100 candidate compounds was completed, of which model projections show tens of promising candidates.
- Successfully synthesized and characterized 13 new alkanolguanidine CO₂BOL derivatives, many of which show promising reductions in viscosity.

next steps

- Assemble new isotherm/viscosity cell to determine vapor-liquid equilibria data, viscosity/density data, and kinetics in the same measurement.
- Scale up synthesis of candidate molecules for experimental testing.

available reports/technical papers/presentations

Heldebrant, D., Final Report, "CO₂-Binding Organic Liquids, Enhanced CO₂ Capture Process with a Polarity-Swing-Assisted Regeneration," August 31, 2014. <http://www.osti.gov/scitech/servlets/purl/1151840>.

"CO₂-Binding Organic Liquids, Enhanced CO₂ Capture Process with a Polarity-Swing-Assisted Regeneration," 2014 CO₂ Capture Technology Meeting, Pittsburgh, PA.

[http://www.netl.doe.gov/File%20Library/Events/2014/2014%20NETL%20CO₂%20Capture/D-Heldebrant-PNNL-CO₂-Binding-Organic-Liquids.pdf](http://www.netl.doe.gov/File%20Library/Events/2014/2014%20NETL%20CO2%20Capture/D-Heldebrant-PNNL-CO2-Binding-Organic-Liquids.pdf).

"CO₂-Binding Organic Liquids, Enhanced CO₂ Capture Process with a Polarity-Swing-Assisted Regeneration," 2013 CO₂ Capture Technology Meeting, Pittsburgh, PA. [http://www.netl.doe.gov/File%20Library/Events/2013/CO₂%20Capture/D-Heldebrant-Battelle--Organic-Liquids-with-PSA-Regen.pdf](http://www.netl.doe.gov/File%20Library/Events/2013/CO2%20Capture/D-Heldebrant-Battelle--Organic-Liquids-with-PSA-Regen.pdf).

"CO₂-Binding Organic Liquids, Enhanced CO₂ Capture Process with a Polarity-Swing-Assisted Regeneration," 2012 CO₂ Capture Technology Meeting, July 2012, Pittsburgh, PA. <http://www.netl.doe.gov/File%20Library/research/coal/carbon%20capture/co2-binding-organic-liquids-gas-capture-july2012.pdf>.

DEVELOPMENT AND DEMONSTRATION OF WASTE HEAT INTEGRATION WITH SOLVENT PROCESS FOR MORE EFFICIENT CO₂ REMOVAL FROM COAL-FIRED FLUE GAS

primary project goals

Southern Company Services is developing viable heat integration methods for the capture of carbon dioxide (CO₂) produced from pulverized coal (PC) combustion. The project will quantify energy-efficiency improvements to the CO₂ capture process by utilizing a waste heat recovery technology, high-efficiency system (HES).

technical goals

- Reduction of the amount of extraction steam required for sensible heat load in the solvent regeneration system by providing process stream heating through waste heat streams.
- Heating of boiler feed water through waste heat to reduce extraction steam demands on the low-pressure (LP) turbine.
- Increasing LP steam available for power generation or CO₂ regeneration.

technical content

Southern Company Services is developing viable heat integration methods for the capture and sequestration of CO₂ produced from PC combustion. A waste heat recovery technology, HES, is being integrated into an existing 25-MW pilot amine-based CO₂ capture process to evaluate improvements in the energy performance of the integrated PC plant and CO₂ capture process. The HES is a heat exchanger that extracts waste heat from flue gas exiting the power plant's air-preheater and makes that heat available for use elsewhere in the power plant and CO₂ recovery plant.

technology maturity:

Pilot-Scale, Actual Flue Gas Slipstream

project focus:

Waste Heat Integration

participant:

Southern Company Services

project number:

FE0007525

NETL project manager:

Bruce Lani
bruce.lani@netl.doe.gov

principal investigator:

Nick Irvin
Southern Company Services
jairvin@southernco.com

partners:

Mitsubishi Heavy Industries

performance period:

10/1/11 – 5/31/16

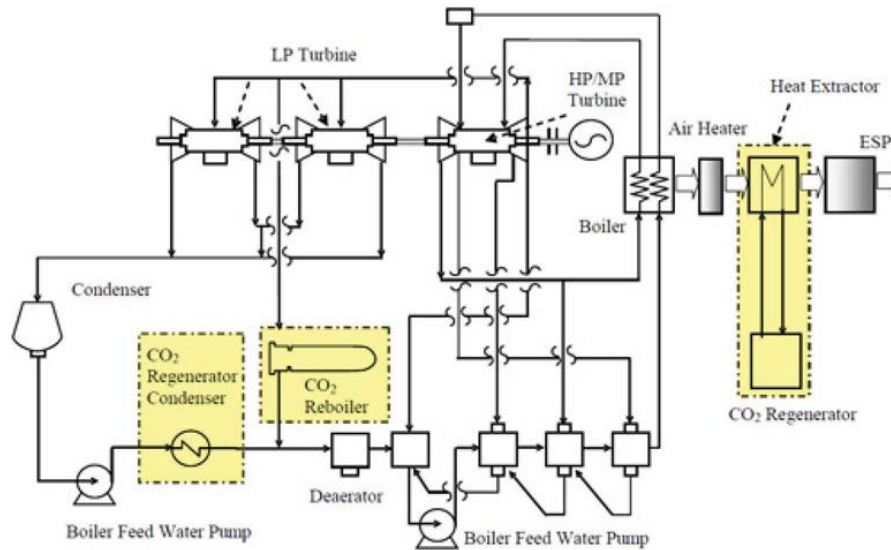

Figure 1: Heat Integration of Power Plant and CCS, Including HES

technology advantages

- The HES provides the efficient use of traditionally wasted heat in coal-fired flue gas and captured CO₂.
- Water usage and parasitic energy loss in carbon capture and storage (CCS) is reduced by the technology.
- The HES accommodates more efficient removal of sulfur trioxide (SO₃) and heavy metals in the electrostatic precipitator by reducing the flue gas temperature and resistivity of fly ash.
- This technology could prove to be a vital method of controlling water usage in a flue gas desulfurization (FGD) due to lower flue gas inlet temperature.

R&D challenges

- Developing and demonstrating control schemes that maintain proper heat balance in the steam cycle and carbon capture plant
- Lowering flue gas temperature after the air-preheater can be problematic due to metal corrosion potential as a result of acid gas condensation; developing specific operating parameters and controls to manage the threat is a specific challenge.

results to date/accomplishments

- A front-end engineering design (FEED) study was completed and a target cost estimate for construction was assembled.
- The techno-economic analysis was completed.
- All equipment was sized and priced.
- The controls architecture was developed.
- A test plan for the operational period was finalized.
- Mechanical completion was achieved and commissioning is near completion.

next steps

Complete commissioning and achieve start-up.

available reports/technical papers/presentations

“Development and Demonstration of Waste Heat Integration with Solvent Process for More Efficient CO₂ Removal from Coal-Fired Flue Gas,” 2014 NETL CO₂ Capture Technology Meeting, Pittsburgh, PA, July 2014.

<http://www.netl.doe.gov/File%20Library/Events/2014/2014%20NETL%20CO2%20Capture/T-Wall-Southern-Waste-Heat-Integration-With-Solvent-Process.pdf>.

“Development and Demonstration of Waste Heat Integration with Solvent Process for More Efficient CO₂ Removal from Coal-Fired Flue Gas,” 2013 NETL CO₂ Capture Technology Meeting, Pittsburgh, PA, July 2013.

<http://www.netl.doe.gov/File%20Library/Events/2013/CO2%20Capture/T-Wall-SouthernCo-Waste-Heat-Integration.pdf>.

“Efficient Use of Waste Heat to Reduce Parasitism of CCS,” 2012 NETL CO₂ Capture Technology Meeting, Pittsburgh, PA, July 2012. <http://www.netl.doe.gov/File%20Library/research/coal/carbon%20capture/efficient-use-waste-heat-reduce-parasitism-july2012.pdf>.

ION ADVANCED SOLVENT CO₂ CAPTURE PILOT PROJECT

primary project goals

ION Engineering is testing its proprietary solvent at the National Carbon Capture Center's (NCCC) Pilot Solvent Test Unit (PSTU) to meet or exceed the DOE goals of 90 percent capture of CO₂ at 95 percent purity and less than \$40/tonne. ION intends to demonstrate scale up potential and performance of the solvent via a 1,000 hour steady state test. The solvent system, comprised of an amine CO₂ capture solvent dissolved in an ionic liquid instead of water, offers higher CO₂ carrying capacity and reduced regeneration energy requirements.

technical goals

- Complete the design and modification of the 0.5-MWe PSTU.
- Prepare ION solvents for pilot testing.
- Perform testing on the PSTU with the ION advanced solvent using coal-fired flue gas to optimize process parameters, determine working capacity.
- Project partner SINTEF will assess chemical and thermal stability of the solvent using their Solvent Degradation Rig (SR) in realistic operating conditions. The projected life and makeup rate of solvent used in process will be determined.
- Complete detailed engineering, solvent degradation analyses, final techno-economic analysis, and EH&S analysis. Provide recommended design configuration and operating conditions when integrated into a 550-MW power plant, and estimate carbon capture cost.

technical content

ION Engineering is testing their novel solvent based CO₂ capture process in the PSTU. The process is based on the use of a novel amine carbon capture solvent developed previously in Department of Energy (DOE)-funded project DE-FE0005799. The project aim is to demonstrate ION's solvent approach for amine-based CO₂ capture, using mixtures of amines and organic solvents, to remove CO₂ from coal-fired flue gas.

ION's solvent system is related to well-understood aqueous amine solvent-based processes in that it utilizes proven amines as chemical solvents for CO₂ capture. However, it differs significantly with the use of an organic solvent, specifically an ionic liquid, in place of water. By using an ionic liquid in place of water, significant reductions in regeneration energy requirements and significantly higher CO₂ loading capacities are anticipated. Reduced parasitic loads, liquid solvent flow rates, and equipment sizes are expected benefits of this system leading to reductions in both capital and operating expenses. Figure 1 shows a power plant with an amine-solvent based carbon capture system.

technology maturity:

Pilot-Scale, Actual Flue Gas Slipstream (0.5 MWe)

project focus:

Amine Solvent in Ionic Liquid

participant:

ION Engineering, LLC

project number:

FE0013303

NETL project manager:

Steven Mascaro
steven.mascaro@netl.doe.gov

principal investigator:

Alfred Brown
ION Engineering, LLC
brown@ion-engineering.com

partners:

Nebraska Public Power District, University of Alabama, Southern Company, SINTEF, Optimized Gas Treating, Trimeric, Sulzer

performance period:

10/1/10 – 3/31/16

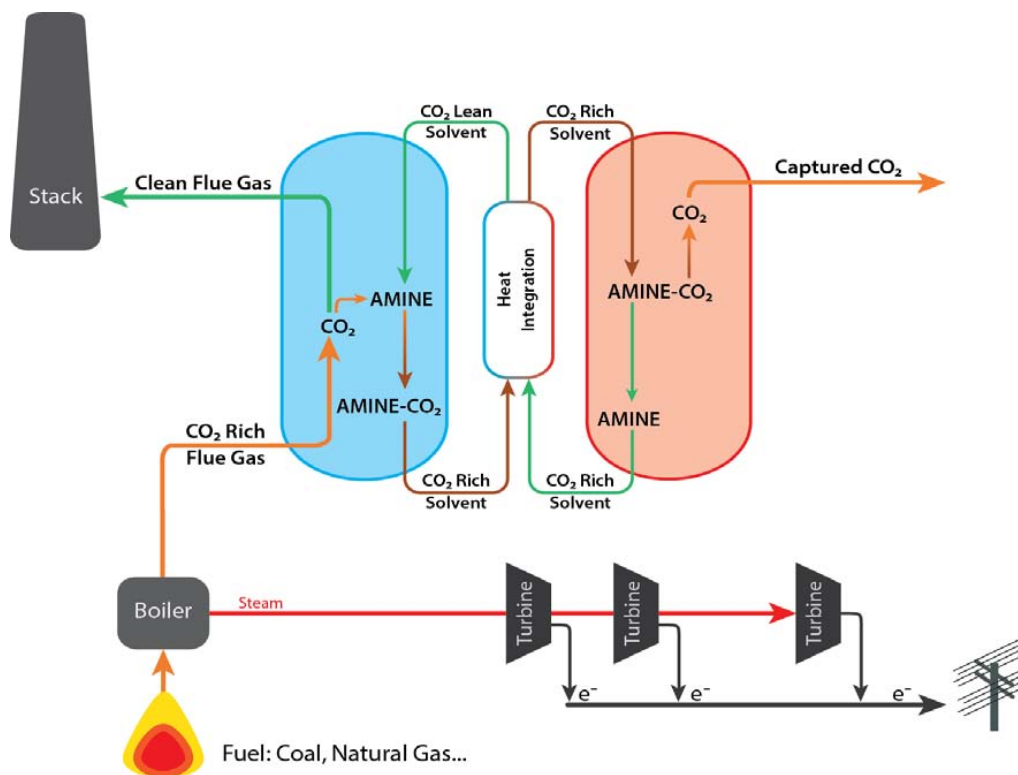

Figure 1: Power Plant with Carbon Capture

ION's solvent-based process steps include caustic scrubbing to remove SO_x , a direct contact cooling unit to control the inlet flue gas temperature, an absorber consisting of a packed column with counter-flow for removal of CO_2 into the proprietary solvent, and water wash to remove solvent droplets and vapors from the exhaust gas. Following the absorption step, the final unit operation is a regenerator to recover the solvent and recycle back to the absorber.

The operation of the slipstream pilot unit supports the development of the novel amine solvent process and provides data for techno-economic assessment of the technology to meet the DOE Carbon Capture program goal of 90 percent CO_2 capture at 95 percent purity at a cost of \$40/tonne.

technology advantages

Relative to state-of-the-art aqueous amine technology, ION's advanced solvent offers:

- Approximately 28 percent reduction in regeneration energy requirements, leading to lower operating and capital costs (48 percent decrease).
- Increased physical solubility of CO_2 in ionic liquid will drive chemical reaction between CO_2 and amine.
- Higher CO_2 loading capacities, leading to lower operating and capital costs.
- Reduced corrosion and solvent losses.
- Faster absorption kinetics.
- Less makeup water used by the process.
- Ability to use lower quality steam in regeneration.

R&D challenges

Solvent stability, degradation, and corrosion potential needs to be investigated under coal-fired slipstream test conditions.

results to date/accomplishments

- Technology EH&S Risk Assessment completed.
- Initial techno-economic analysis completed.
- Selected the National Carbon Capture Center (NCCC) as the host site for the pilot plant.
- To support process model development, completed CO₂ solubility experiments in solvent, determined activation energy of solvent compositions, measured absorption kinetics as function of temperature, and measured physical properties of solvent component binaries versus temperature.
- Completed ION pilot plant final design package based on updated modeling and verification testing.
- To accelerate solvent testing, the project scope was modified to test ION's proprietary solvent at the PSTU.
- Completed a final design package for the ION Pilot Plant which initially was to be installed at NPPD, then at NCCC, then finally dropped from the scope of the project.
- Completed a design package for modifications to the PSTU to accommodate testing of ION's solvent.
- Modification and shakedown of PSTU demonstrated readiness for testing.
- Procured and prepared ION solvents for use in pilot-scale testing.
- Began testing using ION's solvent on the modified PSTU with coal-fired flue gas.

next steps

- Complete testing using ION's solvent on the modified PSTU with coal-fired flue gas.
- Complete final techno-economic analysis.
- Complete final scientific/technical report.

available reports/technical papers/presentations

"ION Advanced Solvent CO₂ Capture Pilot Project," presented by Nathan Brown, ION Engineering, LLC, 2014 NETL CO₂ Capture Technology Meeting, Pittsburgh, PA, July 2014. [http://www.netl.doe.gov/File Library/Events/2014/2014 NETL CO₂ Capture/N-Brown-ION-ION-Advanced-Slipstream-Pilot-Project.pdf](http://www.netl.doe.gov/File%20Library/Events/2014/2014%20NETL%20CO2%20Capture/N-Brown-ION-ION-Advanced-Slipstream-Pilot-Project.pdf).

ION Advanced Solvent CO₂ Capture Pilot Project," Kick-Off Meeting Presentation, December 2013. [http://www.netl.doe.gov/File Library/Research/Coal/carbon capture/post-combustion/fe0013303-Slipstream-Kickoff-Presentation.pdf](http://www.netl.doe.gov/File%20Library/Research/Coal/carbon%20capture/post-combustion/fe0013303-Slipstream-Kickoff-Presentation.pdf).

Brown, N., "Ion Novel Solvent System for CO₂ Capture," 2013 NETL CO₂ Capture Technology Meeting, Pittsburgh, PA, July 2013. [http://www.netl.doe.gov/File%20Library/Events/2013/CO₂%20Capture/N-Brown-ION-Novel-Solvent-System-for-CO₂-Capture.pdf](http://www.netl.doe.gov/File%20Library/Events/2013/CO2%20Capture/N-Brown-ION-Novel-Solvent-System-for-CO2-Capture.pdf).

Carlise, T., "ION Novel Solvent System for CO₂ Capture," 2012 NETL CO₂ Capture Technology Meeting, Pittsburgh, PA, July 2012. [http://www.netl.doe.gov/File%20Library/research/coal/carbon%20capture/ion-novel-solvent-system-CO₂-capture-july2012.pdf](http://www.netl.doe.gov/File%20Library/research/coal/carbon%20capture/ion-novel-solvent-system-CO2-capture-july2012.pdf).

Hohman, J., "ION Novel Solvent System for CO₂ Capture," 2011 NETL CO₂ Capture Technology Meeting, Pittsburgh, PA, August 2011. [http://www.netl.doe.gov/File%20Library/research/coal/carbon%20capture/23Aug-11-Hohman-IE-ION-Solvent-System-for-CO₂-Capture.pdf](http://www.netl.doe.gov/File%20Library/research/coal/carbon%20capture/23Aug-11-Hohman-IE-ION-Solvent-System-for-CO2-Capture.pdf).

"Novel Solvent System for CO₂ Capture," 2010 NETL CO₂ Capture Technology Meeting, Pittsburgh, PA, September 2010. <http://www.netl.doe.gov/File%20Library/research/coal/carbon%20capture/Claude-Corkadel--ION-Engineering-LLC.pdf>

DEVELOPMENT OF MIXED-SALT TECHNOLOGY FOR CARBON DIOXIDE CAPTURE FROM COAL POWER PLANTS

primary project goals

The SRI team, including Aqueous Solutions ApS, Politecnico di Milano, Stanford University, OLI Systems, and IHI Corporation, is demonstrating its novel ammonia- and potassium carbonate-based mixed-salt solvent process at bench scale in order to meet or exceed DOE's overall Carbon Capture program performance goals of 90 percent CO₂ capture rate with 95 percent CO₂ purity at a cost of \$40/tonne of CO₂ captured by 2025.

technical goals

- Demonstrate the absorber and regenerator processes individually for ammonia and potassium carbonate solvent systems with high efficiency and low NH₃ emission and reduced water use compared to the state-of-the-art ammonia-based technologies.
- Demonstrate the high-pressure regeneration and integration of the absorber and the regenerator.
- Demonstrate the complete CO₂ capture system with low cost production of CO₂ stream.
- Optimize the system operation.
- Collect data to perform the detailed techno-economic analysis of CO₂ capture process integration to a full-scale power plant.

technical content

SRI International is developing a novel mixed-salt solvent process for post-combustion CO₂ capture based on combining ammonia- and potassium carbonate-based technologies. This process, shown in Figure 1, utilizes a two-stage absorber system along with the selective mixed salt regenerator to take advantage of the benefits of each individual solvent system while minimizing the disadvantages of the systems used separately. The two-stage absorber operates with the flue gas entering the bottom of the column and contacting the ammonia-rich bottom section, then proceeding to the second stage of the column to contact the potassium-rich solvent section.

technology maturity:

Bench-Scale, Simulated Flue Gas

project focus:

Ammonia- and Potassium Carbonate-Based Mixed-Salt Solvent

participant:

SRI International

project number:

FE0012959

NETL project manager:

Steven Mascaro
steven.mascaro@netl.doe.gov

principal investigator:

Indira Jayaweera
SRI International
indira.jayaweera@sri.com

partners:

Aqueous Solutions ApS
Politecnico di Milano
Stanford University
OLI Systems, Inc.
IHI Corporation

performance period:

10/1/13 – 3/31/16

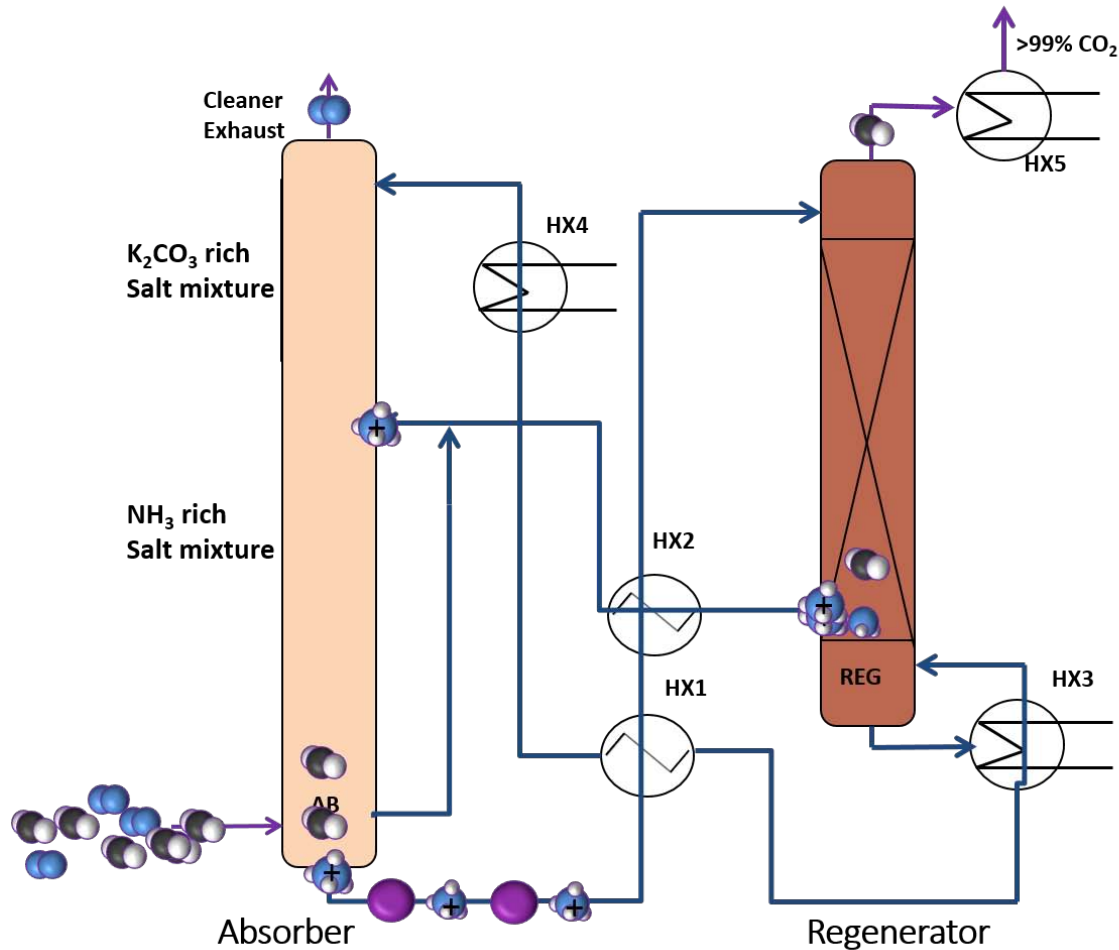

Figure 1: SRI Mixed-Salt Process Simplified Process Diagram

A singular ammonia-based system has several pros: very high CO₂ loading capacity, reduced reboiler duty due to high pressure regeneration, and fast absorption kinetics. Cons of this system include the need for large water wash to reduce ammonia emissions, requirement to chill the solvent, and energy used for solid dissolution. A singular potassium carbonate-based process offers several advantages: no emissions, long-term experience with this technology, and simple permitting. However, this system has lower efficiency and CO₂ loading, as well as energy requirements for solid dissolution and vacuum water stripping.

By combining these two solvent technologies, SRI capitalizes on the advantages of each. The mixed-salt process maintains the high CO₂ loading and enhanced absorption kinetics, delivering high pressure CO₂ in a solids-free system. Further, by combining the salts, the capture system experiences reduced reboiler and auxiliary electricity loads, reduced ammonia emission, reduced water usage, and a reduced footprint. The overall benefit of these improvements is a reduction in the cost of the CO₂ capture.

Bench-scale operation of the individual absorber units provides optimized process parameters prior to the design and testing of the two-stage bench-scale unit. Testing on the two-stage system along with process modeling provides parametric optimization to go along with the techno-economic assessment to determine costs associated with use of this system in a 550 MWe power plant.

The solvent and process parameters identified to date are provided in Table 1.

TABLE 1: SRI SOLVENT PARAMETERS

	Units	Current R&D Value	Target R&D Value
Pure Solvent			
Molecular Weight	mol ⁻¹	18	
Normal Boiling Point	°C	100	
Normal Freezing Point	°C	0	
Vapor Pressure at 15 °C	bar	0.17	
Manufacturing Cost for Solvent	\$/kg		
Working Solution			
Concentration	kg/kg	0.27	0.32
Specific Gravity (15 °C/15 °C)	—	1.37	2.37
Specific Heat Capacity at STP	kJ/kg-K	3.0–3.5	3.0–3.5
Viscosity at STP	cP	0.5 (rich)	0.6 (rich)
Absorption			
Pressure	bar	1	1
Temperature	°C	20–30	25–30
Equilibrium CO ₂ Loading	mol/mol	0.6 (rich)	0.6 (rich)
Heat of Absorption	kJ/mol CO ₂	1,000–1200	<1,000
Solution Viscosity	cP	1.5-1.8	
Desorption			
Pressure	bar	>10	>10
Temperature	°C	110–200	120–180
Equilibrium CO ₂ Loading	mol/mol	0.2 (lean)	<0.2 (lean)
Heat of Desorption	kJ/mol CO ₂		
Proposed Module Design		<i>(for equipment developers)</i>	
Flue Gas Flowrate	kg/hr		
CO ₂ Recovery, Purity, and Pressure	%%/bar	90% recovery, >95% purity, ~20 bar	
Absorber Pressure Drop	bar		

Definitions:

STP – Standard Temperature and Pressure (15 °C, 1 atm).

Pure Solvent – Chemical agent(s), working alone or as a component of a working solution, responsible for enhanced CO₂ absorption (e.g., the amine MEA in an aqueous solution).

Manufacturing Cost for Solvent – “Current” is market price of chemical, if applicable; “Target” is estimated manufacturing cost for new solvents, or the estimated cost of bulk manufacturing for existing solvents.

Working Solution – The solute-free (i.e., CO₂-free) liquid solution used as the working solvent in the absorption/desorption process (e.g., the liquid mixture of MEA and water).

Absorption – The conditions of interest for absorption are those that prevail at maximum solvent loading, which typically occurs at the bottom of the absorption column. These may be assumed to be 1 atm total flue-gas pressure (corresponding to a CO₂ partial pressure of 0.13 bar) and 40 °C; however, measured data at other conditions are preferable to estimated data.

Desorption – The conditions of interest for desorption are those that prevail at minimum solvent loading, which typically occurs at the bottom of the desorption column. Operating pressure and temperature for the desorber/stripper are process-dependent (e.g., an

MEA-based absorption system has a typical CO₂ partial pressure of 1.8 bar and a reboiler temperature of 120 °C). Measured data at other conditions are preferable to estimated data.

Pressure – The pressure of CO₂ in equilibrium with the solution. If the vapor phase is pure CO₂, this is the total pressure; if it is a mixture of gases, this is the partial pressure of CO₂. Note that for a typical PC power plant, the total pressure of the flue gas is about 1 atm and the concentration of CO₂ is about 13.2 percent. Therefore, the partial pressure of CO₂ is roughly 0.132 atm or 0.130 bar.

Concentration – Mass fraction of pure solvent in working solution.

Loading – The basis for CO₂ loadings is moles of pure solvent.

Other Parameter Descriptions:

Chemical/Physical Solvent Mechanism – CO₂ capture mechanism is by chemical absorption

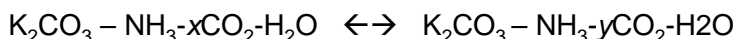

Where $y > x$

Solvent Contaminant Resistance – The solvent is expected to be resistant to several contaminants such as SO_x and NO_x nominally present in a flue gas stream. SO₂ reacts with the solvent, but it can be removed in the DCC (Direct Contact cooler) section as sulfates. The resistance of the solvent to trace metals is not known yet.

Solvent Foaming Tendency – Solvent foaming tendency was not observed in the bench-scale tests.

Flue Gas Pretreatment Requirements – Unlike in MEA system, mixed-salt system does not require deep flue gas desulfurization (FGD). 200 ppm level SO₂ is acceptable.

Solvent Makeup Requirements – Mixed-salt is a mixture of ammonia and K₂CO₃ and it is inexpensive and readily available. The loss of solvent is expected to be <0.2 kg/ tonne of CO₂ captured.

Waste Streams Generated – Ammonium sulfate from the SO₂ and trace capture in the DCC

Proposed Module Design – Unless noted, flue gas feed pressure is 14.7 psia, temperature is 135 °F, and composition leaving the flue gas desulfurization (FGD) unit (wet basis) should be assumed:

Composition (% vol)					Composition (ppmv)	
CO ₂	H ₂ O	N ₂	O ₂	Ar	SO _x	NO _x
13.17	17.25	66.44	2.34	0.8	42	74

technology advantages

- Uses inexpensive, industrially available material.
- Requires no feed stream polishing.
- No hazardous waste generation.
- Has potential for easy permitting.
- Uses known process engineering.
- No solids.
- Enhanced capture rates.
- High CO₂ loading capacity.
- Produces clean CO₂ stream at high pressure.
 - Reduced compression costs.
- Reduced energy consumption compared to MEA.
- Reduced auxiliary electricity loads.

R&D challenges

Reduction of ammonia evaporation at higher reaction rates.

results to date/accomplishments

- Design and installation of absorber completed.
- Regenerator modification and installation completed.
- Absorber and regenerator bench-scale parametric testing completed; 90 percent capture with cyclic loading from 0.16 (lean) to 0.5 (rich).
- Modeling: VLE model update for $K_2CO_3-NH_3-CO_2-H_2O$ completed.
- Power cycle integration for reference plant completed (good agreement with NETL model).

next steps

- Complete design and construction of bench-scale integrated test system.
- Test using integrated system and perform data analysis.
- Model process using test results.
- Prepare techno-economic analysis and EH&S report.

available reports/technical papers/presentations

Jayaweera, I., P. Jayaweera, R. Elmore, J. Bao, S. Bhamidi, "Update on mixed-salt technology development for CO₂ capture from post-combustion power stations," *Energy Procedia* 63, 2014, 640-650.

Jayaweera, I., "Development of Mixed-Salt Technology for Carbon Dioxide Capture from Coal Power Plants," 2014 NETL CO₂ Capture Technology Meeting, Pittsburgh, PA, July 2014.

<http://www.netl.doe.gov/File%20Library/Events/2014/2014%20NETL%20CO2%20Capture/I-Jayaweera-SRI-Development-Of-Mixed-Salt-Technology.pdf>.

Jayaweera et al., "Rate enhancement of CO₂ absorption in aqueous potassium carbonate solutions by an ammonia-based catalyst," WO 2014078212 A1, publication date: May 22, 2014.

Jayaweera, I., "Development of Mixed-Salt Technology for Carbon Dioxide Capture from Coal Power Plants," Project Kick-Off Meeting Presentation, Morgantown, WV, December, 2013. <http://www.netl.doe.gov/File%20Library/Research/Coal/ewr/CO2/SRI-Mixed-Salt-Presentation-121113.pdf>.

Jayaweera, I. S., P. Jayaweera, G. Krishnan, and A. Sanjurjo, "The race for developing promising CO₂ capture technologies ready for 2020 deployment: Novel mixed-salt based solvent technology." *Pap.-Am. Chem. Soc., Div. Energy Fuels* 2013, (1):58.

BENCH-SCALE DEVELOPMENT OF A NONAQUEOUS SOLVENT CO₂ CAPTURE PROCESS FOR COAL-FIRED POWER PLANTS

primary project goals

RTI International is demonstrating, at bench scale, the potential to reduce the thermal regeneration energy associated with the capture of carbon dioxide (CO₂) from flue gas using its nonaqueous solvent (NAS) CO₂ capture process.

technical goals

- Finalize NAS formulation down selection.
- Develop NAS-specific process modifications.
- Experimentally demonstrate, at bench scale, the potential to reduce the thermal regeneration energy to $\leq 2,000$ kJt/kg of CO₂ captured.
- Complete techno-economic assessment and EH&S assessment to evaluate scaleup potential.

technical content

RTI International, teamed with Linde, LLC and SINTEF, is continuing development of a NAS-based CO₂ capture process that was originated at laboratory scale under an ARPA-E project. Nonaqueous solvents have the potential to significantly reduce the cost of CO₂ capture from coal-fired flue gas when compared to aqueous amine-based solvent processes by reducing the energy required for solvent regeneration. RTI's NAS is a hydrophobic, sterically-hindered, carbamate-forming amine with low-water solubility solubilized in a diluent having low vapor pressure, low viscosity, and low-water solubility. It is characterized by low heats of absorption and generation of high CO₂ partial pressures at low temperatures and has the potential to reduce the thermal regeneration energy to $\approx 2,000$ kJt/kg CO₂. Nonaqueous solvents overcome the foaming issues that are often associated with aqueous solvents, as shown in Figure 1. RTI's CO₂-rich nonaqueous solvent has a viscosity of less than 30 cP, and is non-foaming.

technology maturity:

**Bench-Scale Testing,
Simulated Flue Gas**

project focus:

Nonaqueous Solvent

participant:

RTI International

project number:

FE0013865

NETL project manager:

Steven Mascaro
steven.mascaro@netl.doe.gov

principal investigator:

Marty Lail
RTI International
mlail@rti.org

partners:

Linde, LLC
SINTEF

performance period:

10/1/13 – 3/31/16

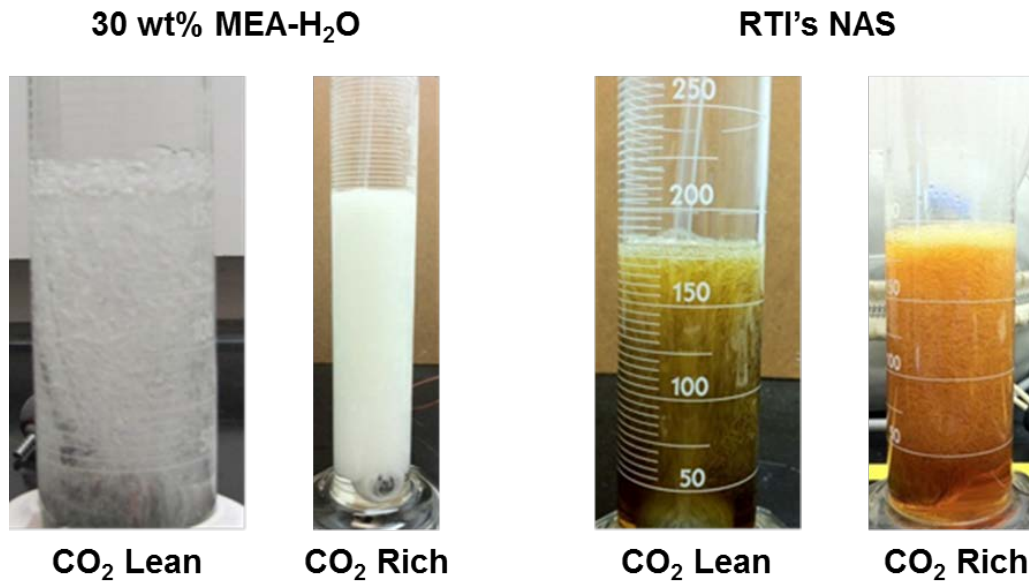
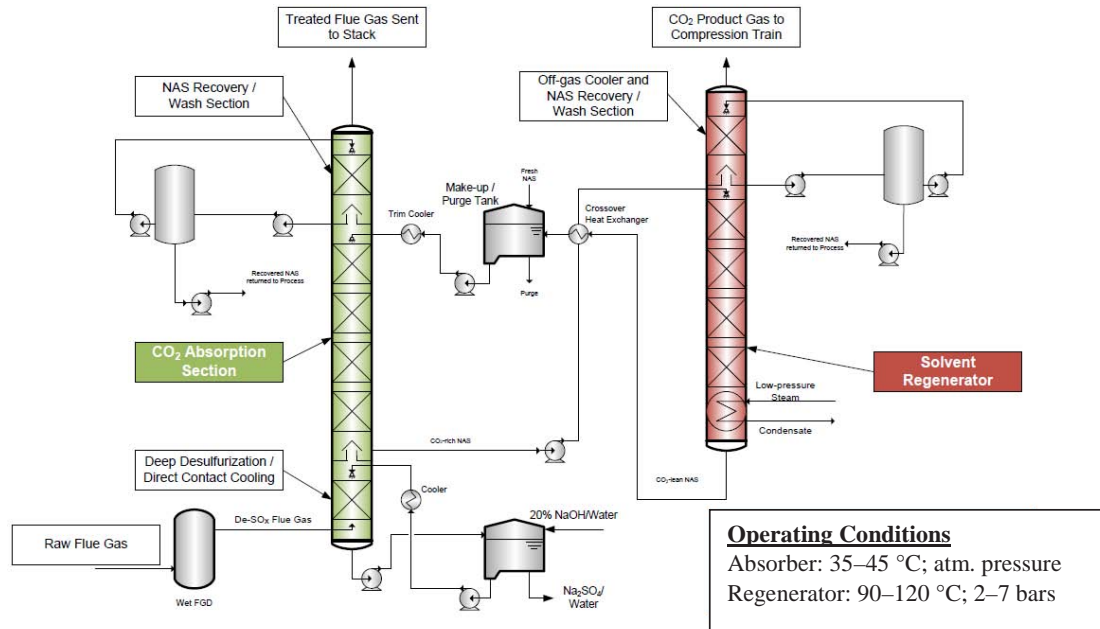

Figure 1: Comparison of Foaming in Aqueous and RTI's Nonaqueous Solvents

RTI's is using its bench-scale testing unit to experimentally demonstrate that its NASs are capable of achieving 90 percent CO₂ capture and generating a high-purity CO₂ product (>95 percent CO₂) as well as evaluate the effectiveness of the developed NAS recovery/wash section and solvent regenerator design (see Figure 2 for process diagram). SINTEF is performing experiments in their solvent degradation test rig (SDR)—a continuous flow system to estimate rate of solvent degradation and determine degradation pathways, determine the necessary flue gas pretreatment requirements specifically pertaining to SO₂ and NO_x, and to speculate and quantify emissions in the treated flue gas stream. RTI and Linde are using test results to complete technical, economic, and environmental, health, and safety (EH&S) assessment to determine the competitiveness, and identify and address EH&S concerns and determine the “permitability” of pilot- and commercial-scale units.

The NAS CO₂ capture process, shown in Figure 2, is similar to conventional scrubbing systems with key design features:

- NAS recovery and wash section—similar to water washing but nonaqueous solvents have low water-solubility.
- Solvent regenerator—lack of low-boiling component (conventional reboilers are not applicable).

Figure 2: NAS CO₂ Capture Process Diagram

technology advantages

- Low water solubility.
- Favorable thermodynamics.
 - Low heat of absorption.
 - High working capacity based on VLE.
- Low vapor pressure (<0.3 kPa (40 °C), <10 ppm emissions in treated flue gas).
- Low conductivity, low corrosion rates.
- Low oxygen solubility.

R&D challenges

- Undesirable reactions with water.
- Solids formation in rich solvent.
- Water balancing.
- Viscosity.
- Solvent cost and availability.
- Emissions in process water and treated flue gas.
- Undesirable impact of water content on ΔH_{abs} .

results to date/accomplishments

- Developed equilibrium thermodynamic models (Kent-Eisenberg and ENRTL-SR).
- Completed construction, commissioning, and validation of lab-scale gas absorber system.
- Completed construction, commissioning, and validation of automated VLE/ ΔH_r system.

- Identified NAS candidates that meet or exceed all selection criteria.
- Determined VLE data and input data into shortcut modeling method which indicates energy penalty of 2,000 kJ/kg CO₂.
- Designed wash section for absorber and showed <10 ppm solvent emissions in treated gas.
- Performed thermal degradation testing at SINTEF which showed thermally stable components.
- Performed oxidative degradation testing at SINTEF which showed oxidative stability.

next steps

- Update the bench-scale unit for evaluating the effectiveness of the NAS recovery and regenerator systems, and calibrate and commission the system.
- Complete a parametric testing campaign with the bench-scale system to evaluate the best candidate NAS and collect experimental data to support a detailed techno-economic analysis.
- Complete solvent degradation studies of the best candidate NAS to determine the impact of common reactive components other than CO₂ in the flue gas.
- Complete development of the rate-based model, validate the model with experimental data, and use the model to interpret experimental data collected from bench-scale testing.
- Perform techno-economic and EH&S analyses of the NAS CO₂ capture process.

available reports/technical papers/presentations

Coleman, L., “Bench-Scale Development of a Nonaqueous Solvent CO₂ Capture Process for Coal-Fired Power Plants,” 2014 NETL CO₂ Capture Technology Meeting, Pittsburgh, PA, July 2014.

<http://www.netl.doe.gov/File%20Library/Events/2014/2014%20NETL%20CO2%20Capture/L-Coleman-RTI-Bench-Scale-Development-Of-A-Nonaqueous-Solvent.pdf>.

PILOT-SCALE SILICONE PROCESS FOR LOW-COST CO₂ CAPTURE

primary project goals

GE Global Research is designing, constructing, and operating a slipstream pilot-scale unit for post-combustion carbon dioxide (CO₂) capture using their novel aminosilicone-based solvent in order to obtain data to optimize the process and establish scalability and potential for reduction in cost of CO₂ capture.

technical goals

- Design pilot-scale system based on novel aminosilicone-based solvent CO₂ capture technology and construct components of system.
- Complete pilot testing on slipstream flue gas to evaluate aminosilicone-based solvent and obtain data for process models.
- Scaleup process model to pilot- and 550 MWe commercial-scale.
- Update EH&S assessment and techno-economic assessment to determine feasibility of commercial scale operation.
- Develop scaleup strategy.
- Develop cost estimate for full-scale manufacture of solvent.

technical content

GE Global Research is designing, constructing, and operating a slipstream pilot-scale process for post combustion CO₂ capture using their novel aminosilicone-based solvent for use in post-combustion capture in coal-fired power plants. The proposed integrated system as installed at the National Carbon Capture Center's (NCCC) Pilot Solvent Test Unit (PSTU) is shown in Figure 1. The process is based on the use of the aminosilicone-based solvent which was developed on the bench-scale in previous US DOE funded projects (DE-FE0007502 and DE-NT0005310). Specifically, the solvent system is composed of a mixture of 60/40 wt/wt GAP-1m/triethylene glycol (TEG). The carbamate formed upon CO₂ absorption does not precipitate out in this solvent mixture. The solvent has a much lower volatility than monoethanolamine (MEA), which simplifies the desorption process and decreases the energy required for CO₂ desorption. The aminosilicone-based CO₂-capture process is predicted to have a 27 percent lower first year removal cost of CO₂ than a comparable MEA process. The solvent can be regenerated at elevated pressures, resulting in lower compression costs. The solvent also shows higher CO₂ capacity, high thermal stability, and low corrosivity.

technology maturity:

Pilot-Scale, Actual Flue Gas Slipstream (0.5 MWe)

project focus:

Novel Aminosilicone Solvent

participant:

GE Global Research

project number:

FE0013755, FE0007502, NT0005310

NETL project manager:

Andrew O'Palko
andrew.opalko@netl.doe.gov

principal investigator:

Benjamin Wood
GE Global Research
woodb@research.ge.com

partners:

Milliken/SiVance, LLC
GE Energy

performance period:

10/1/08 – 12/31/15

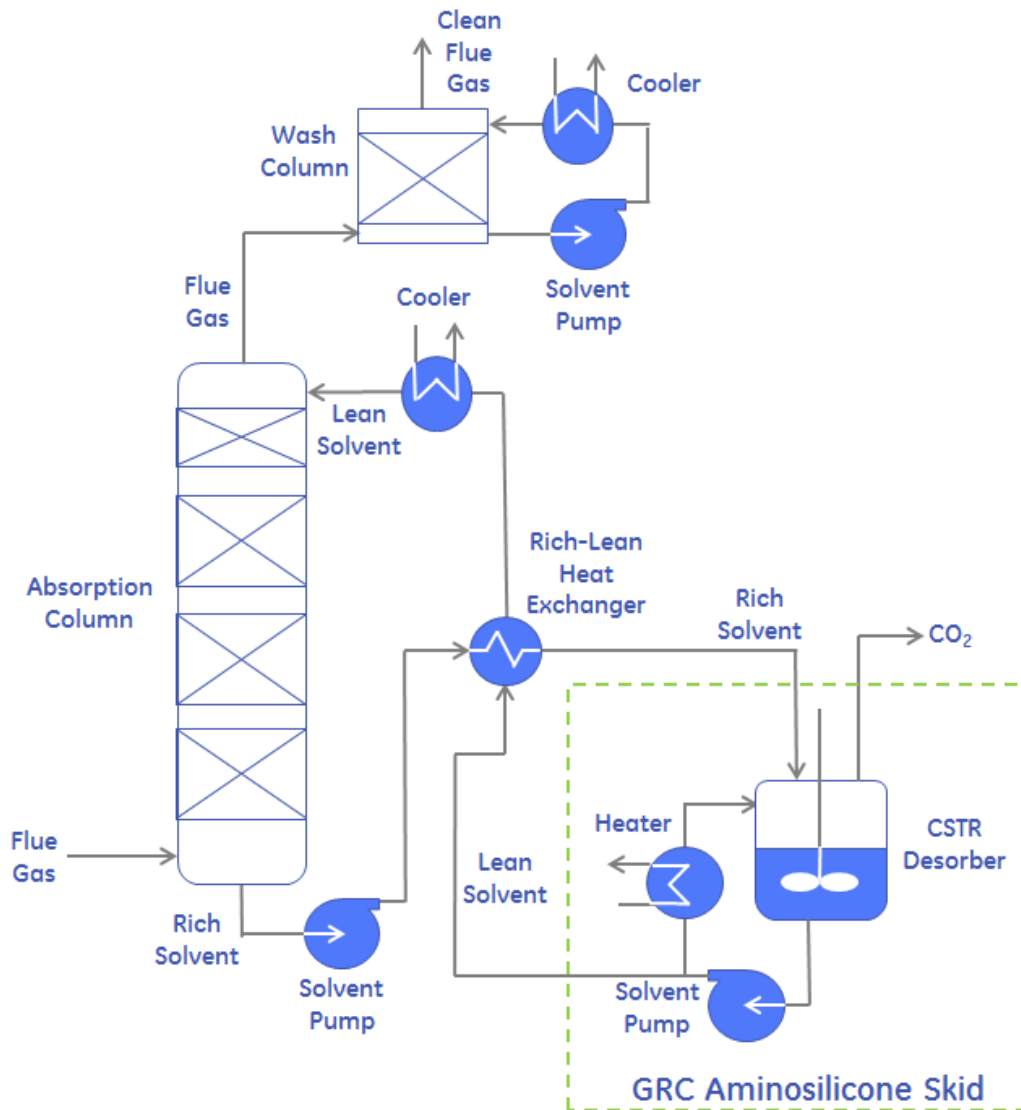

Figure 1: Pilot-Scale System to be Installed at NCCC

Testing on the 0.5 MWe pilot-scale system using coal-fired flue gas provides data, including mass transfer parameters, kinetic parameters, heat transfer parameters, solvent stability, effects of flue gas contaminants, and recommended operating conditions, to update process models and to perform a techno-economic assessment and determine a scaleup strategy. The project aims to establish scalability and technical and economic feasibility of using this aminosilicone-based CO₂-capture absorbent for post-combustion capture of CO₂ from coal-fired power plants with 90 percent capture efficiency and 95 percent CO₂ purity at a cost of \$40/tonne of CO₂ captured.

The solvent and process parameters identified to date are provided in Table 1.

TABLE 1: PROCESS PARAMETERS FOR GE NOVEL AMINOSILICONE-BASED SOLVENT

	Units	Current R&D Value	Target R&D Value
Pure Solvent			
Molecular Weight	mol ⁻¹	322.67 (GAP-1 _m)/150.17 (TEG)	322.67 (GAP-1 _m)/150.17 (TEG)
Normal Boiling Point	°C	310 (GAP-1 _m)/287 (TEG)	310 (GAP-1 _m)/287 (TEG)
Normal Freezing Point	°C	-85 (GAP-1 _m)/-7 °C (TEG)	-85 (GAP-1 _m)/-7 °C (TEG)
Vapor Pressure at 15 °C	bar	0.005 bar @ 140 °C (TEG) 0.037 bar @ 140 °C (GAP-1 _m)	0.005 bar @ 140 °C (TEG) 0.037 bar @ 140 °C (GAP-1 _m)
Manufacturing Cost for Solvent	\$/kg		
Working Solution			
Concentration	kg/kg	60/40 GAP-1 _m /TEG	60/40 GAP-1 _m /TEG
Specific Gravity (22 °C/20 °C)	—	0.913 (GAP-1 _m)/1.124 (TEG)	0.913 (GAP-1 _m)/1.124 (TEG)
Specific Heat Capacity at 40 °C and 1 bar	kJ/kg-K	2.319 (60/40 GAP-1 _m /TEG)	2.319 (60/40 GAP-1 _m /TEG)
Viscosity at STP	cP	4.37 (GAP-1 _m)/49 (TEG)	4.37 (GAP-1 _m)/49 (TEG)
Absorption			
Pressure	bar	0 (gauge)	0 (gauge)
Temperature	°C	40-60 °C	40-60 °C
Equilibrium CO ₂ Loading	mol/mol	0.78 (CO ₂)/1 (GAP-1 _m)	0.78 (CO ₂)/1 (GAP-1 _m)
Heat of Absorption	kJ/mol CO ₂	99.7 (60/40 GAP-1 _m in TEG)	99.7 (60/40 GAP-1 _m in TEG)
Solution Viscosity	cP	431 (60/40 GAP-1 _m in TEG)	431 (60/40 GAP-1 _m in TEG)
Desorption			
Pressure	bar	2 (gauge)	2 (gauge)
Temperature	°C	140 °C	140 °C
Equilibrium CO ₂ Loading	mol/mol	0.25 (CO ₂)/1 (GAP-1)	0.25 (CO ₂)/1 (GAP-1)
Heat of Desorption	kJ/mol CO ₂	99.7 (60/40 GAP-1 _m in TEG)	99.7 (60/40 GAP-1 _m in TEG)
Proposed Module Design		<i>(for equipment developers)</i>	
Flue Gas Flowrate	kg/hr	2268	
CO ₂ Recovery, Purity, and Pressure	%/%/bar	90/95/3 bara	
Absorber Pressure Drop	bar		

Definitions:

STP – Standard Temperature and Pressure (15 °C, 1 atm).

Pure Solvent – Chemical agent(s), working alone or as a component of a working solution, responsible for enhanced CO₂ absorption (e.g., the amine MEA in an aqueous solution).

Manufacturing Cost for Solvent – “Current” is market price of chemical, if applicable; “Target” is estimated manufacturing cost for new solvents, or the estimated cost of bulk manufacturing for existing solvents.

Working Solution – The solute-free (i.e., CO₂-free) liquid solution used as the working solvent in the absorption/desorption process (e.g., the liquid mixture of MEA and water).

Absorption – The conditions of interest for absorption are those that prevail at maximum solvent loading, which typically occurs at the bottom of the absorption column. These may be assumed to be 1 atm total flue-gas pressure (corresponding to a CO₂ partial pressure of 0.13 bar) and 40 °C; however, measured data at other conditions are preferable to estimated data.

Desorption – The conditions of interest for desorption are those that prevail at minimum solvent loading, which typically occurs at the bottom of the desorption column. Operating pressure and temperature for the desorber/stripper are process-dependent (e.g., an MEA-based absorption system has a typical CO₂ partial pressure of 1.8 bar and a reboiler temperature of 120 °C). Measured data at other conditions are preferable to estimated data.

Pressure – The pressure of CO₂ in equilibrium with the solution. If the vapor phase is pure CO₂, this is the total pressure; if it is a mixture of gases, this is the partial pressure of CO₂. Note that for a typical PC power plant, the total pressure of the flue gas is about 1 atm and the concentration of CO₂ is about 13.2 percent. Therefore, the partial pressure of CO₂ is roughly 0.132 atm or 0.130 bar.

Concentration – Mass fraction of pure solvent in working solution.

Loading – The basis for CO₂ loadings is moles of pure solvent.

Other Parameter Descriptions:

Chemical/Physical Solvent Mechanism – The reaction of the GAP class of aminosilicones with CO₂ is shown in Figure 2. The aminosilicone in this study is a mixture of GAP molecules where the average value of the subscript (x) shown in Figure 2 is one. This solvent is designated GAP-1. GAP-1 is combined with TEG in a 60/40 (by weight) mixture to inhibit the solidification that occurs when the neat solvent (GAP-1) reacts with CO₂.

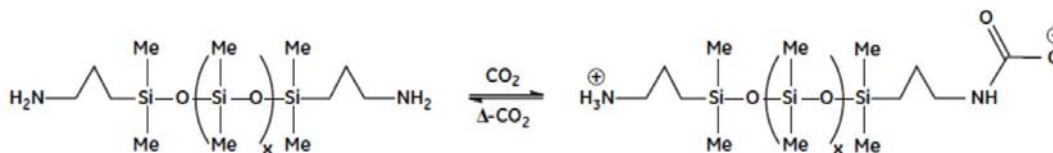

Figure 2: Reaction of GAP Class of Aminosilicones with CO₂ to Form GAP Carbamate

Solvent Contaminant Resistance – As with MEA, aminosilicones will react irreversibly with sulfur dioxide (SO₂) to form heat-stable salts (HSS). Solvent makeup will be required to replace aminosilicone lost to reaction with SO₂.

Solvent Foaming Tendency – None observed.

Flue Gas Pretreatment Requirements – In a full-scale system, the flue gas pretreatment requirements are identical to those of an MEA-based process, including a selective catalytic reduction reactor, particulate removal, and flue gas desulfurizer (FGD).

Solvent Makeup Requirements – In addition to the solvent makeup required due to reaction of aminosilicone with SO₂, additional solvent makeup will be required due to thermal decomposition. However, it has been demonstrated that GAP-1 is significantly more thermally stable than MEA, as discussed below.

Waste Streams Generated – A waste stream of HSS from the reaction of SO₂ with aminosilicone will be generated.

Process Design Concept – The process flow diagram for the aminosilicone-based, bench-scale CO₂-capture system is shown in Figure 3.

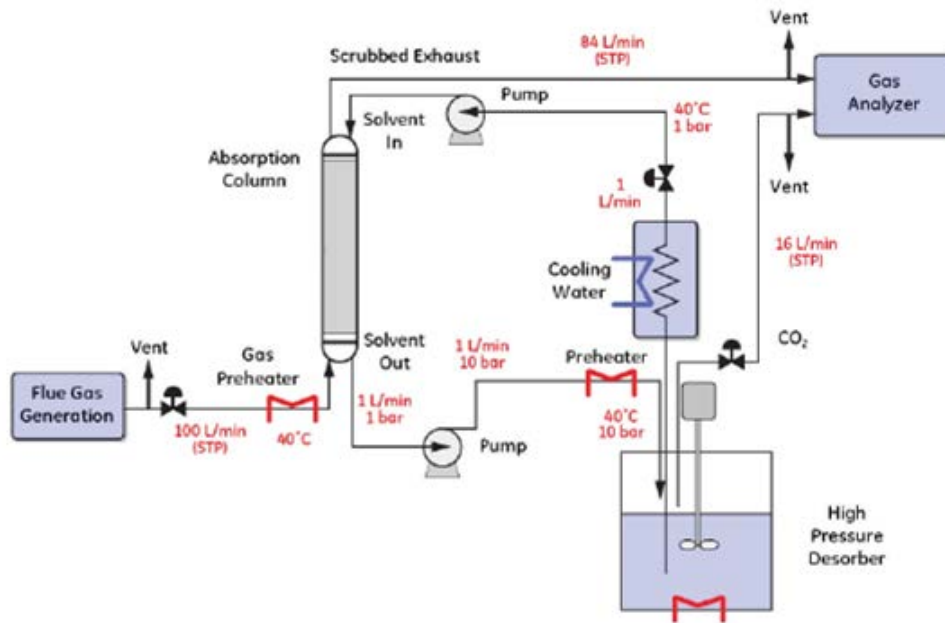

Figure 3: The Process Flow Diagram for the Bench-Scale System

Proposed Module Design – Unless noted, flue gas feed pressure is 14.7 psia, temperature is 135 °F, and composition leaving the FGD unit (wet basis) should be assumed:

Composition (% vol)					Composition (ppmv)	
CO ₂	H ₂ O	N ₂	O ₂	Ar	SO _x	NO _x
13.17	17.25	66.44	2.34	0.80	42	74

technology advantages

- Higher thermal stability, higher desorption temperature, greater CO₂ capture capacity.
 - Lower volatility.
 - Simplified separations.
 - Lower energy wasted vaporizing solvent.
- Reduced emissions.
- Lower heat capacity.
- Reduced corrosion.
- Ability to remove water.
- Potential for decreased issues with aerosol formation.

R&D challenges

- High viscosity of solvent at low temperatures and high CO₂ loading.
- Higher heat of reaction.
- Cost of the solvent.

results to date/accomplishments

- Thermal stability test (150–180 °C for ≈90 days) results showed that the GAP-1/TEG solvent was stable at 150 °C.
- Successfully completed the design and assembly of a continuous, bench-scale absorption (flue gas flow rate up to 200 standard liters per min [SLPM], 40 °C)/desorption unit.
- A model of the bench-scale system was built and scaled up to model the performance of a carbon capture unit, using aminosilicones, for CO₂ capture and sequestration (CCS) for a pulverized coal (PC) boiler at 550 MWe. The first year removal cost of CO₂ for the aminosilicone-based carbon-capture process is \$44.12/ton of CO₂ as compared to \$60.25/ton of CO₂ when MEA is used.
- Completed engineering package for pilot plant design.
- Completed detailed design of pilot plant test skid for integration at NCCC.
- HAZOP completed on the pilot plant skid design.
- Completed skid fabrication

next steps

- Integrate the skid with PSTU at NCCC.
- Operate pilot plant using novel aminosilicone-based solvent to obtain data.
- Update process models with pilot plant data.
- Update techno-economic analysis and EH&S assessment.

available reports/technical papers/presentations

“Pilot-Scale Silicone Process for Low-Cost CO₂ Capture,” presented by Benjamin Wood, GE Global Research, 2014 NETL CO₂ Capture Technology Meeting, Pittsburgh, PA, July 2014. [http://www.netl.doe.gov/File Library/Events/2014/2014 NETL CO₂ Capture/B-Wood-GE-Pilot-Scale-Silicone-Process.pdf](http://www.netl.doe.gov/File%20Library/Events/2014/2014%20NETL%20CO2%20Capture/B-Wood-GE-Pilot-Scale-Silicone-Process.pdf).

Final Report, “Bench-Scale Silicone Process for Low-Cost CO₂ Capture,” December 2013. <http://www.osti.gov/scitech/servlets/purl/1133118>.

“Bench-Scale Silicone Process for Low-Cost CO₂ Capture,” 2013 NETL CO₂ Capture Technology Meeting, July 2013. [http://www.netl.doe.gov/File%20Library/Events/2013/CO₂%20Capture/B-Wood-GE-Bench-Scale-Silicone-Process.pdf](http://www.netl.doe.gov/File%20Library/Events/2013/CO2%20Capture/B-Wood-GE-Bench-Scale-Silicone-Process.pdf).

Wood, B., “Bench-Scale Silicone Process for Low-Cost CO₂ Capture,” 2012 NETL CO₂ Capture Technology Meeting, July 2012. <http://www.netl.doe.gov/File%20Library/Research/Coal/ewr/co2/bench-scale-silicone-process-low-cost-july2012.pdf>.

GE Global Research, 2011, “Bench-Scale Silicone Process for Low-Cost CO₂ Capture,” Project Kick-Off Meeting Presentation, November 22, 2011. <http://www.netl.doe.gov/File%20Library/Research/Coal/ewr/co2/bench-scale-silicone-process-low-cost-kickoff-nov2011.pdf>.

Perry, R.J., et. al., “Aminosilicones for CO₂ Capture,” *ChemSusChem*, 2010, August 23, 3(8): 919-930.

Technical Report, “Bench-Scale Silicone Process for Low-Cost CO₂ Capture. Manufacturing Plan for Aminosilicone-Based CO₂ Absorption Material,” January 7, 2013. <http://www.osti.gov/scitech/biblio/1134752>.

COMBINED PRESSURE AND TEMPERATURE CONTRAST SEPARATION OF CARBON DIOXIDE FOR POST-COMBUSTION CARBON CAPTURE

primary project goals

Rice University is developing a novel process for the separation of carbon dioxide (CO₂) from flue gas from conventional, pulverized coal-fired power plants. The process aims to combine solvent absorber and stripper columns into a single integrated unit. The combined absorber and stripper system benefits from using a high surface area ceramic foam gas-liquid contactor for enhanced mass transfer. The project includes bench-scale testing of the system.

technical goals

- Combine absorber and stripper columns into a single, integrated process unit to achieve significant cost savings in capital costs and to mitigate space availability constraints.
- Use a high surface area ceramic foam gas-liquid contactor for enhanced mass transfer.
- Use vacuum stripping in combination with waste heat for regeneration of a CO₂ solvent.
- Assess the potential to functionalize the ceramic gas-liquid contactors with solid catalyst for enhanced CO₂ desorption.
- Evaluate the use of catalysts for CO₂ desorption.
- Determine best absorbent and operating conditions for the process.
- Develop a 2-D model to simulate gas and liquid flow in the capture process.
- Perform a techno-economic analysis.

technical content

The technical approach involves the integration of the absorber and stripper sections into a single unit. Figure 1 shows a schematic of a combined absorber and stripper unit. In Figure 1, the region shaded in blue represents a gas-liquid contactor on the absorption side whereas the region shaded in red represents the same on the stripping side. The gas-liquid contactor must possess a large geometric surface area for good gas-liquid contacting. For liquid to be transported from the absorption to stripping side, horizontal flow of the liquid is a requirement. This can take place in two ways, either by flow through the connected pores of a ceramic contactor or as a liquid film moving over the surface of a contactor with a complex three-dimensional structure.

technology maturity:

Bench-Scale, Simulated Flue Gas

project focus:

Novel Absorption/Stripper Process

participant:

William Marsh Rice University

project number:

FE0007531

NETL project manager:

Elaine Everitt
elaine.everitt@netl.doe.gov

principal investigator:

Michael S. Wong
William Marsh Rice University
mswong@rice.edu

partners:

N/A

performance period:

10/1/11 – 12/31/15

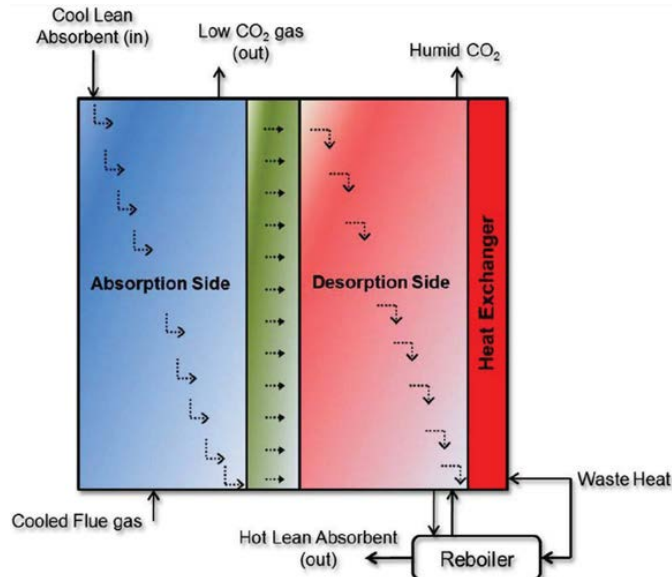

Figure 1: Schematic of Combined Pressure and Temperature Contrast and Surface-Enhanced Separation of CO₂

A bench-scale prototype of the gas absorption process will be developed to study various aspects of fluid flow in the system. A simulation model for the process is also being developed to optimize the properties of ceramics being used and the process operating conditions.

The expected outcomes of this project include significant reduction in the capital and operating costs of the gas absorption process and a resulting decrease in cost of electricity (COE). The use of waste heat instead of high-quality steam provides a significant reduction in operating costs. An integrated absorber and stripper unit substantially reduces capital costs.

Parameter Descriptions:

Chemical/Physical Solvent Mechanism – High surface area ceramic foam gas-liquid contactor for enhanced mass transfer.

Solvent Contaminant Resistance – This novel process uses advanced gas-liquid contactor materials called “ceramic foams.” Ceramic foams have dual porosity (large, visible macropores and microscopic pores in the ceramic matrix) and can be made from a variety of materials (the ones being used currently are made of 99.5 percent α -alumina [Al₂O₃], which has excellent heat and chemical resistance). In the future, the cost of these materials can be reduced significantly by working with cheaper ceramics, such as silica.

Solvent Foaming Tendency – Not applicable, conventional amine absorbents are being studied.

Flue Gas Pretreatment Requirements – As with all membrane processes, particulates (both those that enter with flue gas and solids formed due to side-reactions in the absorbent) can reduce the system performance. Since this research is currently at bench scale, the effects of particulates cannot be conclusively commented on. However, based on the understanding of the system, it is not anticipated to be a severe problem.

Solvent Makeup Requirements – To be determined.

Waste Streams Generated – Since work will continue with conventional amine absorbents, production of any waste streams is not anticipated, other than those already handled at amine absorption units.

technology advantages

- An integrated absorber and desorber unit and the use of high-geometric surface-area ceramic foam packing will result in significant reductions in capital cost.
- Waste heat used for absorbent regeneration significantly reduces parasitic duty for a power plant and will limit the increase in COE.
- Operating the desorber at lower temperatures decreases amine losses, equipment corrosion and energy cost.
- CO₂ desorption with catalysts can potentially reduce the energy consumption for regeneration.

R&D challenges

- Scalability.
- Lack of published literature describing the performance of ceramic foams as tower packing.
- Lack of process model.
- Pairing a conventional absorption process with a vacuum stripper.
- Lack of published literature on the use of catalysts for CO₂ stripping.

results to date/accomplishments

- Studied hydrodynamic properties of off-the-shelf alumina foams purchased from commercial supplier.
- Compared the CO₂-pickup performance of 20-, 30-, and 45-ppi alumina foam with that of 6-mm Raschig rings; also estimated the performance for 25-mm Raschig rings. Estimates show that 20-ppi ceramic foam has a better performance than the 25-mm Raschig rings.
- Performed an initial technical and economic feasibility study to demonstrate that the process proposed by the Rice University team has a capital cost comparable to that of the Fluor Econamine process and results in significantly lower COE with the use of waste heat.
- Designed and tested bench-scale combined absorption/desorption unit, including substrate functionalization.
- Demonstrated CO₂ absorption and desorption using 30 wt% Diglycolamine in an integrated absorber-stripper unit made with stainless steel.
- Developed 1-D and 2-D process model and simulation to describe CO₂ capture in the integrated absorber/desorber unit was established.

next steps

- Continue process optimization to reduce energy requirements and cost.
- Complete assessment of the concept of catalysis to lower stripper operating temperatures.
- Update the initial feasibility and economic analysis with information generated in this project for pilot scale-up.

available reports/technical papers/presentations

“Combined Pressure and Temperature Contrast and Surface-Enhanced Separation of Carbon Dioxide for Post-Combustion Carbon Capture,” 2014 NETL CO₂ Capture Technology Meeting, Pittsburgh, PA, July 2014.

<http://www.netl.doe.gov/File%20Library/Events/2014/2014%20NETL%20CO2%20Capture/M-Wong-Rice-Combined-Separation-of-CO2-.pdf>.

“Combined Pressure and Temperature Contrast and Surface-Enhanced Separation of Carbon Dioxide for Post-Combustion Carbon Capture,” 2012 NETL CO₂ Capture Technology Meeting, Pittsburgh, PA, July 2012.

<http://www.netl.doe.gov/File%20Library/events/2012/CO2%20capture%20meeting/G-Hirasaki-Rice-Combined-Separations.pdf>.

“Combined Pressure and Temperature Contrast and Surface-Enhanced Separation of Carbon Dioxide for Post-Combustion Carbon Capture,” Project Kick-Off Meeting, November 2011. http://www.netl.doe.gov/File%20Library/Research/Coal/ewr/CO2/Rice-DOE-Kick-off-Meeting-Presentation-Nov-7-8-2011_sanitize.pdf.

EVALUATION OF CONCENTRATED PIPERAZINE FOR CO₂ CAPTURE FROM COAL-FIRED FLUE GAS

primary project goals

URS Group, Inc. (URS) is investigating the use of a high-temperature flash regenerator using concentrated piperazine (PZ) solvent to capture carbon dioxide (CO₂) from coal flue gas more economically. Pilot tests and analyses will be conducted at the 0.1-megawatt (MW) scale, and then scaled to the 0.5-MW scale for testing at the National Carbon Capture Center (NCCC). Results will be used to evaluate the technical and economic feasibility of a full-scale implementation of this process.

technical goals

- Quantify and demonstrate the robustness of concentrated PZ with coal-fired flue gas in an integrated absorption/stripping system with solvent regeneration at 150 °C.
- Optimize equipment design and energy performance of the innovative flash system.
- Identify and resolve other potential operational and design issues, including amine aerosol emissions, process control, corrosion, foaming, and solids precipitation.

technical content

URS, in collaboration with the University of Texas (UT) and Trimeric Corporation, will investigate the use of concentrated PZ as a solvent for absorbing CO₂ from coal-fired power plant flue gas. Measured properties of PZ are shown in Table 1. Evaluations of concentrated PZ for CO₂ removal have previously been performed through laboratory investigations, process modeling, and synthetic flue gas testing in a 0.1-MW unit. Results indicated greater than 90 percent CO₂ capture with significant reduction in the cost of electricity (COE). This project continues the development of the PZ-based CO₂ absorption process through a series of field tests to gain operational experience with the solvent in coal-fired flue gas, while employing a novel, high-temperature, two-stage flash (2SF) regeneration design.

The project team is conducting this project in two phases. In the first phase, the PZ absorption process was combined with a novel regeneration scheme—a high-temperature 2SF, shown in Figure 1. A 3-week test was conducted in synthetic flue gas at the 0.1-MW scale using PZ in the absorption column at UT's Separations Research Program (SRP) plant, coupled with the project team's 0.1-MW 2SF system. The results from the SRP test program and the techno-economic analysis demonstrated the benefits of using PZ as a solvent-of-choice for CO₂ capture. The results from the SRP test program demonstrated that 2SF regeneration is a viable alternative regeneration process to simple stripping; however, the techno-economic analysis showed only a marginal economic benefit of the 2SF process. Therefore additional testing at the 0.1 MW scale has been performed to demonstrate the advanced flash stripper.

Based on the project findings thus far, the project team recommended to DOE's National Energy Technology Laboratory (NETL) that the 2SF regeneration process not be scaled up for a test campaign at NCCC. Since one of the main objectives of this project is to

technology maturity:

Pilot-Scale, Simulated Flue Gas and Actual Flue Gas Slipstream

project focus:

Piperazine Solvent with Flash Regeneration

participant:

URS Group

project number:

FE0005654

NETL project manager:

Bruce Lani

bruce.lani@netl.doe.gov

principal investigator:

Katherine Dombrowski
URS Group, Inc.

katherine.dombrowski@urscorp.com

partners:

Trimeric Corporation,
University of Texas at Austin

performance period:

10/1/10 – 9/30/15

address operational and design issues of the PZ process, the project team recommended to DOE/NETL that project resources be allocated toward investigating and solving critical solvent management issues that are common to amine solvents, including PZ. DOE/NETL approved the project team to use the project resources remaining in Phase I to study aerosol formation in the absorber. Aerosols have been implicated in high amine emissions from absorbers at several pilot plants. The project team will conduct tests at UT's SRP plant to investigate possible mechanisms for aerosol formation. After completion of the aerosol tests at the SRP plant, the project team will submit a continuation application to DOE/NETL to proceed to Phase II, in which PZ will be tested at the 0.5-MW scale on coal-fired flue gas at NCCC.

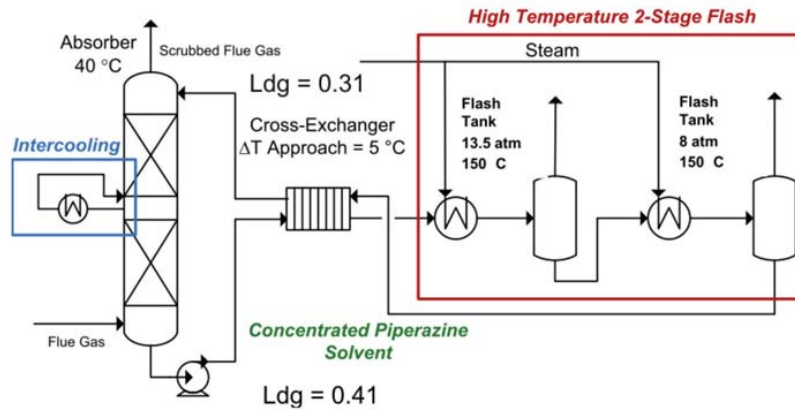

Figure 1: Diagram of PZ CO₂ Absorption Process with High-Temperature Two-Stage Flash

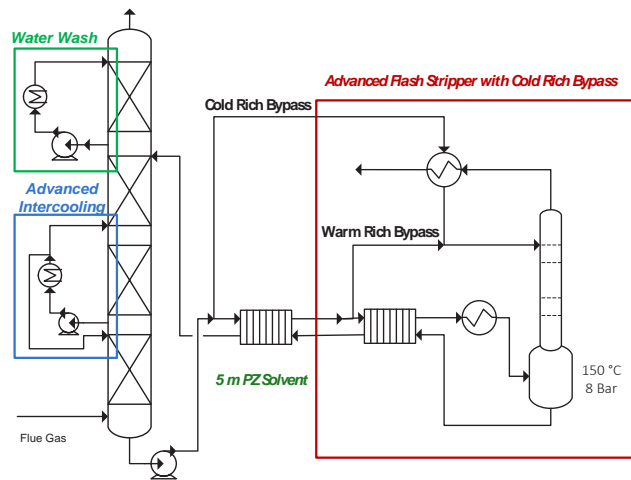

Figure 1a. PZ CO₂ Absorption with the Advanced Flash Stripper

TABLE 1: PROCESS PARAMETERS FOR 8 MOLAL PIPERAZINE SOLVENT

	Units	Current R&D Value
Molecular Weight	mol ⁻¹	86.14
Normal Boiling Point	°C	146
Normal Freezing Point	°C	106
Vapor Pressure at 15 °C	bar	0.000206
Manufacturing Cost for Solvent	\$/kg	\$60/lb eq N
Working Solution		
Concentration	kg/kg	30%
Specific Gravity (15 °C/15 °C)	—	1.02
Specific Heat Capacity at STP	kJ/kg-K	3.2
Viscosity at STP	cP	7
Absorption		
Pressure	bar	0.05
Temperature	°C	40
Equilibrium CO ₂ Loading	mol/mol	0.8
Heat of Absorption	kJ/mol CO ₂	70
Solution Viscosity	cP	3.2
Desorption		
Pressure	bar	6
Temperature	°C	150
Equilibrium CO ₂ Loading	mol/mol	0.44
Heat of Desorption	kJ/mol CO ₂	70

Definitions:

STP – Standard Temperature and Pressure (15 °C, 1 atm).

Pure Solvent – Chemical agent(s), working alone or as a component of a working solution, responsible for enhanced CO₂ absorption (e.g., the amine monoethanolamine [MEA] in an aqueous solution).

Manufacturing Cost for Solvent – “Current” is market price of chemical, if applicable; “Target” is estimated manufacturing cost for new solvents, or the estimated cost of bulk manufacturing for existing solvents.

Working Solution – The solute-free (i.e., CO₂-free) liquid solution used as the working solvent in the absorption/desorption process (e.g., the liquid mixture of MEA and water).

Absorption – The conditions of interest for absorption are those that prevail at maximum solvent loading, which typically occurs at the bottom of the absorption column. These may be assumed to be 1 atm total flue-gas pressure (corresponding to a CO₂ partial pressure of 0.13 bar) and 40 °C; however, measured data at other conditions are preferable to estimated data.

Desorption – The conditions of interest for desorption are those that prevail at minimum solvent loading, which typically occurs at the bottom of the desorption column. Operating pressure and temperature for the desorber/stripper are process-dependent (e.g., an MEA-based absorption system has a typical CO₂ partial pressure of 1.8 bar and a reboiler temperature of 120 °C). Measured data at other conditions are preferable to estimated data.

Pressure – The pressure of CO₂ in equilibrium with the solution. If the vapor phase is pure CO₂, this is the total pressure; if it is a mixture of gases, this is the partial pressure of CO₂. Note that for a typical pulverized coal (PC) power plant, the total pressure of the flue gas is about 1 atm and the concentration of CO₂ is about 13.2 percent. Therefore, the partial pressure of CO₂ is roughly 0.132 atm or 0.130 bar.

Concentration – Mass fraction of pure solvent in working solution.

Loading – The basis for CO₂ loadings is moles of pure solvent.

Other Parameter Descriptions:

Chemical Solvent Mechanism – The reaction of PZ with CO₂ involves formation of the following four PZ species:

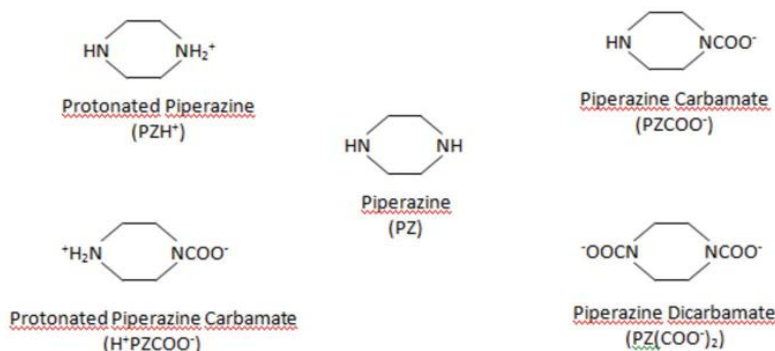

Figure 2: Molecular Structure of Piperazine Species¹

These reactions are as follows:

1. $\text{PZH}^+ + \text{H}_2\text{O} \leftrightarrow \text{PZ} + \text{H}_3\text{O}^+$
2. $\text{PZ} + \text{CO}_2 + \text{H}_2\text{O} \leftrightarrow \text{PZCOO}^- + \text{H}_3\text{O}^+$
3. $\text{H}_2\text{O} + \text{H}^+\text{PZCOO}^- \leftrightarrow \text{H}_3\text{O}^+ + \text{PZCOO}^-$
4. $\text{PZCOO}^- + \text{CO}_2 + \text{H}_2\text{O} \leftrightarrow \text{PZ}(\text{COO}^-)_2 + \text{H}_3\text{O}^+$

TABLE 2: EQUILIBRIUM CONSTANTS FOR ABOVE REACTIONS¹

Eq. No.	Equilibrium Constant	$\ln K = A + B/T + C \ln T$		
		A	B	C
1	$K_1 = \frac{x_{\text{PZ}}x_{\text{H}_3\text{O}^+}}{x_{\text{H}_2\text{O}}x_{\text{PZH}^+}}$	-11.91	-4,351	—
2	$K_2 = \frac{x_{\text{H}_3\text{O}^+}x_{\text{PZCOO}^-}}{x_{\text{PZ}}x_{\text{CO}_2}x_{\text{H}_2\text{O}}}$	-29.31	5,615	—
3	$K_3 = \frac{x_{\text{H}_3\text{O}^+}x_{\text{PZCOO}^-}}{x_{\text{H}^+}x_{\text{PZCOO}^-}x_{\text{H}_2\text{O}}}$	-8.21	-5,286	—
4	$K_4 = \frac{x_{\text{H}_3\text{O}^+}x_{\text{PZ}(\text{COO}^-)_2}}{x_{\text{PZCOO}^-}x_{\text{CO}_2}x_{\text{H}_2\text{O}}}$	-30.78	5,615	—

This speciation and solubility model has been used to predict the partial pressure of CO₂ and mole fraction of species in solution as a function of PZ loading; the results show a good match between the model and the experimental data.

Solvent Contaminant Resistance – 5-m PZ is thermally stable at 150 °C with negligible oxidative (Freeman, 2011) degradation. The total amine loss is estimated to be 0.5 percent per week when stripping at 150 °C. At 135 °C, the estimated total amine loss of PZ is 0.3 percent as compared to 3.0 percent in the case of an MEA solvent. PZ forms nitrosamines and other nitro products with nitrogen dioxide (NO₂). Both pilot-scale flue gas testing and bench-scale testing have confirmed that nitrosamines decompose at temperatures of 150 °C and greater. The main degradation products of PZ are formate (0.04 mM/hr) and ammonia (0.09 mM/hr) (Freeman, 2011).

Solvent Foaming Tendency – Pilot plant tests of PZ with two different sources of coal-fired flue gas and with air/CO₂ have experienced no persistent problems with foaming. However, bench-scale experiments have shown the possibility for PZ to foam under certain conditions (e.g., after undergoing oxidation degradation). In the bench-scale tests, foaming of PZ was greatly reduced with use of an oxidation inhibitor or with use of 1 part per million (ppm) of silicone antifoam (Chen, 2011).

Flue Gas Pretreatment Requirement – Tests at UT's SRP plant were performed on synthetic flue gas composed of air and CO₂. NCCC tests will be conducted on medium-sulfur bituminous coal flue gas cleaned by flue gas desulfurization (FGD). Commercial applications would likely need sulfur oxides (SO_x) to be removed to levels below 10 ppm.

Solvent Makeup Requirements – Including an estimate for additional amine lost in the reclaiming process, the required makeup rate is estimated to be 0.76 kg of 30 wt% PZ per metric ton of CO₂ captured for PZ regenerated at 150 °C. The estimated makeup rate for 30 wt% MEA at 120 °C is approximately 2.0 kg/MT CO₂.

Waste Streams Generated – The major amine solid/liquid waste streams come from reclaiming waste. There could be fugitive liquid amine emissions, which can be controlled by incorporating seamless valves, rupture disks, closed-loop ventilation systems, pumps with dual mechanical seals, minimum welds, and correct gasket material selection. Gas-phase amine emissions from the absorber can be minimized by controlling aerosol formation and aerosol emissions from the absorber. Gas-phase amine emissions from the stripper can be minimized by controlling temperature of the CO₂ outlet gas and via operating conditions of the condenser.

Process Design Concept – Flowsheet/block flow diagram shown above.

Proposed Module Design – Unless noted, flue gas feed pressure is 1.014 bara, temperature is 57 °C, and composition leaving the flue gas desulfurization (FGD) unit (wet basis) should be assumed:

Composition (% vol)					Composition (ppmv)	
CO ₂	H ₂ O	N ₂	O ₂	Ar	SO _x	NO _x
13.17	17.25	66.44	2.34	0.80	42	74

technology advantages

As compared to conventional amine solvents, the advantages of PZ are:

- Faster CO₂ absorption rate, higher working capacity, higher thermal stability, and less oxidative degradation—all of which point toward 10–20 percent less energy use.
- Lower capital costs due to reduced energy use, greater stripper pressure (reduced compressor size), and faster kinetics.
- Additional savings in COE may be achieved by optimization of absorber packing, flue gas pre-treating, compressors, heat exchangers, and design improvements realized as part of this project.

R&D challenges

- Similar to other amines, PZ may absorb on aerosols in flue gas leading to poor amine collection in the water wash after CO₂ absorption and thus high amine emissions.
- PZ reacts with dissolved or entrained oxygen (O₂) at temperatures exceeding 150 °C, potentially leading to greater than expected solvent makeup, but still less than MEA. Techniques to reduce oxidative degradation, including sparging with N₂, or flashing at T < 100 °C are being investigated.
- Robustness of concentrated PZ in flue gas and thermal reclaiming of degraded solvent needs to be demonstrated, because PZ is more expensive to replace than MEA.
- PZ forms as a solid phase with water (PZ • 6H₂O) and also with CO₂ (H⁺PZCOO⁻ • H₂O). Process robustness to excursions in CO₂ loading, temperature, and water balance is being demonstrated by quantifying their effects on solids precipitation and plant operation.

results to date/accomplishments

- UT-SRP tests demonstrated integration of a high-temperature 2SF (13.5 atm, 8 atm) stripping process with low-thermal degradation, and quantified mass transfer and energy performance with 8-m PZ.
- Operating conditions for 90 percent CO₂ removal (0.31 lean loading, 0.41 rich loading) with high-temperature PZ regeneration were identified.
- The CO₂ removal rate was improved by 6–7 percent with spray intercooling in the absorber during the 0.1-MW test campaign at UT SRP.
- Minimal solids precipitation was observed in steady-state operation.
- Process analyses indicated that the high-temperature 2SF process increased the COE by 62.6 percent compared to 81.7 percent increase for MEA. The energy consumption was lowered to 230 kWh/T CO₂.
- Process analysis showed that purchased equipment costs for capture and compression were reduced for the PZ high-temperature 2SF process versus PZ with a simple stripper, but the simple stripper process had slightly better energy performance; these two effects essentially canceled each other out in terms of impact on COE.
- UR-SRP tests demonstrated integration of a high temperature advanced flash stripper (150 °C, 6 atm) and quantified mass transfer and energy performance with 5 m PZ.

next steps

- Further tests (during NCCC 0.5-MW testing) are needed to demonstrate reliable operation on coal-fired flue gas and during longer term operation in which excursions of CO₂ loading, temperature, and water balance are encountered.
- Solvent degradation in coal-fired flue gas and methods to reduce oxidative solvent degradation will be evaluated during NCCC tests.
- PZ aerosol mitigation technologies (DOE scope) will be tested alongside the next-generation advanced flash stripper configuration (non-DOE scope) at the SRP pilot plant.

available reports/technical papers/presentations

Rochelle, G., “Pilot Plant Testing of Piperazine with High T Regeneration,” presented at the 2014 NETL CO₂ Capture Technology Meeting, Pittsburgh, PA, July 2014.

Rochelle, G., “Pilot Plant Testing of Piperazine with High T Regeneration,” presented at the 2013 NETL CO₂ Capture Technology Meeting, Pittsburgh, PA, July 2013. <http://www.netl.doe.gov/File%20Library/Events/2013/CO2%20Capture/G-Rochelle-UTA-Concentrated-Piperazine-for-CO2-Capture.pdf>.

Rochelle, G., “Pilot Plant Testing of Piperazine with High T Regeneration,” presented at the 2012 NETL CO₂ Capture Technology Meeting, Pittsburgh, PA, July 2012.

Freeman, S.A., 2011, “Thermal Degradation and Oxidation of Aqueous Piperazine for Carbon Dioxide Capture,” Ph.D. Thesis, University of Texas at Austin. <http://repositories.lib.utexas.edu/handle/2152/ETD-UT-2011-05-3290>.

Sexton, A., “Evaluation of Concentrated Piperazine for CO₂ Capture from Coal-Fired Flue Gas,” presented at the 2011 NETL CO₂ Capture Technology Meeting, Pittsburgh, PA, August 2011.

Dombrowski, K., “Evaluation of Concentrated Piperazine for CO₂ Capture from Coal-Fired Flue Gas,” presented at the 2010 NETL CO₂ Capture Technology Meeting, Pittsburgh, PA, September 2010.

Fine, N. A.; Goldman, M. J.; Nielsen, P. T.; Rochelle, G. T., “Managing N-nitrosopiperazine and Dinitrosopiperazine,” presented at GHGT-11 Kyoto, Japan. November 18–22, 2012. Energy Procedia, 2013.

Fulk, S. M.; Rochelle, G. T., “Modeling Aerosols in Amine-Based CO₂ Capture.” GHGT-11; Energy Proc. 2013.

Madan, T.; “Stripper Configurations and Modeling for CO₂ Capture Using Piperazine.” M. S. Thesis. The University of Texas at Austin, May 2013.

Nielsen, P. T.; Li, L.; Rochelle, G. T., “Piperazine Degradation in Pilot Plants.” GHGT-11; Energy Proc. 2013.

LOW-ENERGY SOLVENTS FOR CO₂ CAPTURE ENABLED BY A COMBINATION OF ENZYMES AND VACUUM REGENERATION

primary project goals

Novozymes is leading a team composed of the University of Kentucky, Doosan Power Systems, and Pacific Northwest National Laboratory (PNNL), which is designing, building, and testing an integrated bench-scale system that combines the attributes of an enzyme catalyst (carbonic anhydrase [CA]) with low-enthalpy absorption liquids and vacuum regeneration for a carbon dioxide (CO₂) capture process with improved efficiency, economics, and sustainability.

technical goals

- Conduct preliminary evaluation of the potential for ultrasonic regeneration to deliver a lean-loading equivalent to the lean loading predicted with vacuum stripping at 70 °C.
- Optimize enzyme-promoted potassium carbonate (K₂CO₃)-based solvent for maximum CO₂ absorption rate.
- Demonstrate enzyme robustness for meeting targeted bench-scale test conditions.
- Design and build an integrated bench-scale unit incorporating the vacuum regeneration component to validate stripping performance at 70–80 °C.
- Demonstrate system performance and benefits based on completion of 500 hours of testing.
- Complete a full technology assessment of the process and potential for meeting significant reductions in net parasitic load compared to conventional scrubbing technology for post-combustion CO₂ capture.

technical content

The Novozymes-led team will design, build, and test an integrated bench-scale system that combines the attributes of the bio-renewable enzyme carbonic anhydrase (CA) with low-enthalpy absorption liquids and vacuum regeneration. Preliminary evaluation of a novel ultrasonically enhanced regeneration system was also made. The objective is to develop a CO₂ capture process with improved efficiency and economics when compared with existing CO₂ scrubber technologies.

The application of CA accelerates inter-conversion between dissolved CO₂ and bicarbonate ion, which is the rate-limiting step for absorption and desorption in low enthalpy of reaction solutions that rely on ionic complexation of CO₂. The use of low enthalpy CO₂ absorption solvents offers the opportunity to regenerate the solvent at lower temperatures relative to existing CO₂ scrubber technologies. The system will be evaluated with respect to energy requirement and enzyme effects in a process where the enzyme is dissolved and recirculates through the absorber and reduced-temperature stripper.

technology maturity:

Bench-Scale, Simulated Flue Gas

project focus:

Enzyme and Vacuum Combination Technology

participant:

Novozymes

project number:

FE0007741

NETL project manager:

Andrew Jones
andrew.jones@netl.doe.gov

principal investigator:

Sonja Salmon
Novozymes
SISA@novozymes.com

partners:

University of Kentucky,
Doosan Power Systems,
Ltd.,
Pacific Northwest
National Laboratory

performance period:

10/1/11 – 6/30/15

A replenishment program to compensate for active enzyme loss while maintaining system performance will also be evaluated.

In one method of low temperature stripping, application of ultrasonic energy transforms dissolved CO₂ into gas bubbles, thereby increasing the overall driving force of the solvent regeneration reaction. The ultrasonic effect known as rectified diffusion could have the potential to yield lean solvent CO₂ loading equivalent to vacuum stripping. In the preliminary simulation, ultrasonic technology was projected to reduce the net parasitic load to a coal-fired power plant by as much as 50 percent compared to NETL Case 10 monoethanolamine (MEA) scrubbing technology. Several different configurations of the prototype ultrasonic regenerator were evaluated, including combination with vacuum and novel incorporation of a hydrocyclone to enhance gas-liquid separation. The magnitude of measured CO₂ release was within the range of temperature-dependent release, meaning that application of ultrasonics could provide thermal regeneration effects. However, additional work would be required to validate whether rectified diffusion could replace the vacuum requirement at low stripping temperatures.

Another method of achieving low temperature stripping is to apply vacuum to decrease the solvent boiling point to ≈70–80 °C, and provide driving force for the regeneration. Process simulations of this approach have been made indicating that the use of low-enthalpy solvents, which could require very low pressure steam during the regeneration cycle, together with vacuum has the potential to require 43 percent less parasitic power from a coal-fired power plant compared to NETL Case 10 MEA scrubbing technology. It is recognized that application of vacuum would have a corresponding compression penalty downstream of the CO₂ capture unit. Therefore, the aim of the evaluation is to demonstrate the feasibility of the vacuum approach by a combination of bench-scale system testing and corresponding projections of feasibility at 550-MWe scale.

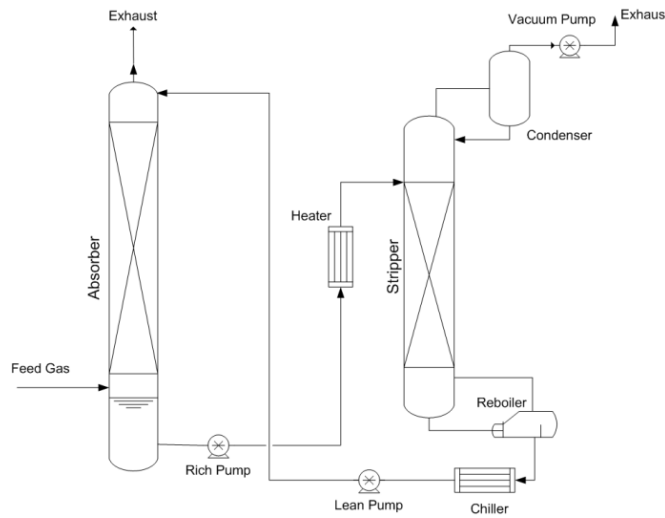

Figure 1: Bench-Scale Process Schematic

TABLE 1: PROCESS PARAMETERS

	Units	Current R&D Value	Target R&D Value
Pure Solvent			
Molecular Weight	mol ⁻¹	138.21	138.21
Normal Boiling Point	°C	N/A	N/A
Normal Freezing Point	°C	N/A	N/A
Vapor Pressure at 15 °C	bar	N/A	N/A
Manufacturing Cost for Solvent	\$/kg	1.3	<1.3
Working Solution			
Concentration	kg/kg	0.23	0.23
Specific Gravity (15 °C/15 °C)	—	1.21	1.21
Specific Heat Capacity at STP	kJ/kg-K	≈3.4b	≈3.4b
Viscosity at STP	cP	≈1.4	≈1.4

Absorption			
Pressure	bar	1	1
Temperature	°C	30–40	30–50
Rich CO ₂ Loading	mol/mol	0.55	0.67
Heat of Absorption	kJ/mol CO ₂	27	27
Solution Viscosity	cP	≈1.4	≈1.4
Desorption			
Pressure	bar	0.35	0.35
Temperature	°C	77	70–80
Lean CO ₂ Loading	mol/mol	0.35	0.3
Heat of Desorption	kJ/mol CO ₂	27	27

Definitions:

N/A – Not applicable.

STP – Standard Temperature and Pressure (15 °C, 1 atm).

Pure Solvent – Chemical agent(s), working alone or as a component of a working solution, responsible for enhanced CO₂ absorption (e.g., the amine MEA in an aqueous solution).

Manufacturing Cost for Solvent – “Current” is market price of chemical, if applicable; “Target” is estimated manufacturing cost for new solvents, or the estimated cost of bulk manufacturing for existing solvents.

Working Solution – The solute-free (i.e., CO₂-free) liquid solution used as the working solvent in the absorption/desorption process (e.g., the liquid mixture of MEA and water).

Absorption – The conditions of interest for absorption are those that prevail at maximum solvent loading, which typically occurs at the bottom of the absorption column. These may be assumed to be 1 atm total flue-gas pressure (corresponding to a CO₂ partial pressure of 0.13 bar) and 40 °C; however, measured data at other conditions are preferable to estimated data.

Desorption – The conditions of interest for desorption are those that prevail at minimum solvent loading, which typically occurs at the bottom of the desorption column. Operating pressure and temperature for the desorber/stripper are process-dependent (e.g., an MEA-based absorption system has a typical CO₂ partial pressure of 1.8 bar and a reboiler temperature of 120 °C). Measured data at other conditions are preferable to estimated data.

Pressure – The pressure of CO₂ in equilibrium with the solution. If the vapor phase is pure CO₂, this is the total pressure; if it is a mixture of gases, this is the partial pressure of CO₂. Note that for a typical pulverized-coal power plant, the total pressure of the flue gas is about 1 atm and the concentration of CO₂ is about 13.2 percent. Therefore, the partial pressure of CO₂ is roughly 0.132 atm or 0.130 bar.

Concentration – Mass fraction of pure solvent in working solution.

Loading – The basis for CO₂ loadings is moles of pure solvent.

a. Working solution additionally contains CA enzyme catalyst.

b. Technical Data: Properties of Potassium Carbonate. Armand Products Company. http://www.armandproducts.com/pdfs/k2so3P33_46.pdf

Other Parameter Descriptions:*Chemical/Physical Solvent Mechanism –*

1. $\text{CO}_{2(\text{g})} \leftrightarrow \text{CO}_{2(\text{aq})}$ (gas-liquid physical mass transfer)
2. $\text{CO}_{2(\text{aq})} + \text{HO}^- \leftrightarrow \text{HCO}_3^-$
3. $\text{HCO}_3^- + \text{HO}^- \leftrightarrow \text{CO}_3^{2-} + \text{H}_2\text{O}$ ($\text{pK}_a = 10.3$)
4. $\text{CO}_{2(\text{aq})} + \text{H}_2\text{O} \leftrightarrow \text{H}_2\text{CO}_3$
5. $\text{H}_2\text{CO}_3 + \text{HO}^- \leftrightarrow \text{HCO}_3^- + \text{H}_2\text{O}$ ($\text{pK}_a = 6.4$)
6. $\text{H}_2\text{O} \leftrightarrow \text{H}^+ + \text{HO}^-$

For the solvent system in the proposed operating range (pH 9-11), Reaction 2 and reactions 4 together with 5 are responsible for the absorption of CO_2 into the liquid phase as bicarbonate. CA enzyme catalyzes Reaction 6 in the enzyme active site to produce a zinc-hydroxide nucleophile that reacts with CO_2 to produce and release bicarbonate according to Reaction 2. The proton produced during Reaction 6 is transferred from the active site to the reaction medium where the proton is neutralized by the alkalinity and buffering capacity of the medium. The transfer of proton away from the active site has been determined in the literature as the rate limiting step for CA catalysis.

The kinetics of CO_2 absorption in CA enzyme/ K_2CO_3 solution were measured using the wetted-wall column technique. The current enzyme/ K_2CO_3 solvent supports a mass transfer rate ≥ 50 percent the rate of benchmark 30 percent MEA.

Solvent Contaminant Resistance – Publications by Akermin, Inc. (DE-FE0004228 and DE-FE0012862) and the University of Illinois (DE-FC26-08NT0005498) demonstrate the robustness of enzyme-promoted K_2CO_3 solvents to typical flue gas contaminants at lab scale.

Solvent Foaming Tendency – Based on bench-scale tests, solvent foaming can be mitigated by antifoam, as necessary.

Flue Gas Pretreatment Requirements – No special requirements expected beyond conventional pretreatment for particulate, sulfur oxide (SO_x), and nitrogen oxide (NO_x) removal.

Solvent Makeup Requirements – Preliminary feasibility study assumed a K_2CO_3 makeup rate of 0.1 ton/day and continuous enzyme reclamation from 0.05 percent lean solvent slipstream. These appear to be underestimates and the solvent makeup requirements are being revised for the final TEA.

Waste Streams Generated – Waste stream consists of K_2CO_3 salts and biodegradable enzyme, which could be used as compost, fertilizer or boiler fuel.

Process Design Concept – Bench-scale process schematic is shown in Figure 1.

Proposed Module Design – Unless noted, flue gas feed pressure is 1.014 bara, temperature is 57 °C, and composition leaving the flue gas desulfurization (FGD) unit (wet basis) should be assumed:

Composition (% vol)					Composition (ppmv)	
CO_2	H_2O	N_2	O_2	Ar	SO_x	NO_x
13.17	17.25	66.44	2.34	0.80	42	74

technology advantages

- The energy required for solvent regeneration is provided by low-temperature steam and vacuum.
- Enzyme helps overcome the inherently slow reaction rates of the K_2CO_3 based solvent, which have previously made its use for atmospheric CO_2 scrubbing prohibitive. Enzyme-enhanced rates of CO_2 absorption compared to aqueous K_2CO_3 without CA could lead to capital cost savings.
- By providing enzyme in dissolved form, conventional liquid handling approaches can be used to adjust enzyme dose and replenishment rates to achieve optimal system performance.

- K_2CO_3 has chemical handling advantages due to negligible vapor pressure, no flash point, no odor, no degradation, good safety and environmental profile, and ready availability.
- Potential for lowering the parasitic load by ≈ 40 percent (vacuum case) to ≈ 50 percent (ultrasonics case) compared to NETL Case 10 MEA technology, leading to lower fuel costs.
- Potential environmental, health and safety (EH&S) benefits compared to MEA.

R&D challenges

- Scaleup of the vacuum and ultrasonic regeneration systems from lab- to bench-scale (10–30 standard liters/minute [SLPM] gas, 0.1–0.30 LPM solvent) to provide sufficient lean loading to support 90 percent capture.
- Ultrasonic test system showed tendency towards rapid CO_2 re-dissolution of generated gases and foaming phenomena, which pointed to the need for specialized gas removal in the continuous system. Further work is needed to verify predicted ultrasonic advantages.
- Enzyme dose required to achieve and maintain 90 percent capture.
- Accurate scale up of bench scale data to full scale predictions using process models.
- Practicality of vacuum equipment to handle CO_2 gas flow at 550 MWe scale.
- Utilization of a VLP turbine for extracting the solvent regeneration steam at 8 psia (and 85 °C).
- Utilization of alternative materials of construction to reduce the capital cost of plant, such as the use of concrete columns, plastic packing materials, etc.

results to date/accomplishments

- The developmental CA used throughout the project was sufficiently robust to enable data collection across test conditions that included exposure to ultrasonics and travel through a reboiler with bulk liquid temperatures up to 80 °C.
- Demonstrated CO_2 release via the addition of ultrasonic energy at approximately one third of the CO_2 release target in laboratory-scale batch tests; however, at less than 5 percent of the target for the single-pass flow-through system. Ultrasonics could merit further study across broader parametric ranges.
- Results from preliminary techno-economic analysis indicate that the increase in the levelized cost-of-electricity (LCOE) could be ≈ 20 percent lower for the ultrasonics case and ≈ 12 percent lower for the vacuum case when compared to a power plant with CO_2 capture based on the NETL reference Case 10 MEA technology.
- CO_2 absorption mass transfer rate for the enzyme/ K_2CO_3 -solvent remained essentially constant over a 30 to 50 °C temperature range.
- 30 SLPM bench-scale unit shakedown and parametric testing was completed, providing a unique test data matrix for low-pressure/low-temperature stripping with enzyme-enhanced K_2CO_3 -based solvent. The target 90 percent CO_2 capture efficiency was achieved during shakedown tests with a 30 °C absorber temperature; however, the 500 hour test was conducted with a 40 °C absorber temperature to better match expected power plant operational conditions. 500-hour testing in the 30 SLPM bench-scale unit operating with a 40 °C absorber was completed, demonstrating that >84 percent CO_2 capture efficiency can be maintained under low-pressure/low-temperature stripping conditions with enzyme-enhanced K_2CO_3 -based solvent through implementing a program of enzyme replenishment.
- Preliminary EH&S assessment for enzyme-activated aqueous potassium carbonate solution determined that potential emissions were found to pose no significant concerns and were compliant with the Federal legislation reviewed. Evaluation on a larger-scale test unit with flue gas would be needed to verify the findings through operational measurements.

next steps

- A full-scale, techno-economic analysis to be completed.

available reports/technical papers/presentations

House, A., “Low-Energy Solvents for CO₂ Capture Enabled by a Combination of Enzymes and Vacuum Regeneration,” AIChE 2014 Meeting, Atlanta, GA, November 17, 2014. <http://www.netl.doe.gov/File%20Library/Research/Coal/carbon%20capture/post-combustion/FE0007741-AIChE-2014-Presentation-11-17-2014.pdf>.

Salmon, S., “Low-Energy Solvents for Carbon Dioxide Capture Enabled by a Combination of Enzymes and Vacuum Regeneration,” Novozymes North America, Inc., 2014 NETL CO₂ Capture Technology Meeting, Pittsburgh, PA, July 2014. <http://www.netl.doe.gov/File%20Library/Events/2014/2014%20NETL%20CO2%20Capture/S-Salmon-Novozymes-Low-Energy-Solvents.pdf>.

Salmon, S., “Low-Energy Solvents for Carbon Dioxide Capture Enabled by a Combination of Enzymes and Vacuum Regeneration,” Novozymes North America, Inc., 2013 NETL CO₂ Capture Technology Meeting, Pittsburgh, PA, July 2013. <http://www.netl.doe.gov/File%20Library/Events/2013/CO2%20Capture/S-Salmon-Novozymes-Low-Energy-Solvents.pdf>.

Swaminathan, S., Agnieszka Kuczynska, A., Hume, S. and Mulgundmath, V., Freeman, C. and Bearden, M., Remias, J., and Ambedkar, B., Salmon, S., and House, A., “Preliminary Technical and Economic Feasibility Study on the Integration of a Process Utilizing Low-Energy Solvents for Carbon Dioxide Capture Enabled By a Combination of Enzymes and Ultrasonics with a Subcritical PC Power Plant, Topical Report, Reporting Period October 1, 2011–October 31, 2012,” Report Issued October 2012. <http://www.netl.doe.gov/File%20Library/Research/Coal/ewr/CO2/FE0007741-PreliminaryTech-economic-Feasibility-Study.pdf>.

Salmon, S., “Low-Energy Solvents for Carbon Dioxide Capture Enabled by a Combination of Enzymes and Ultrasonics,” Project Review Meeting, October 2012. http://www.netl.doe.gov/File%20Library/Research/Coal/ewr/CO2/DE-FE0007741-netl-project-review-bp1-Oct2012_FINAL.pdf.

Salmon, S., “Lab-Scale Assessment of a Post-Combustion Carbon Dioxide Capture Process Enabled by a Combination of Enzymes and Ultrasonics,” 2012 Pittsburgh Coal Conference, Pittsburgh, PA, October 2012. <http://www.netl.doe.gov/File%20Library/Research/Coal/ewr/CO2/ipcc-oct2012-session11-salmon.pdf>.

Salmon, S., “Low-Energy Solvents for Carbon Dioxide Capture Enabled by a Combination of Enzymes and Ultrasonics,” 2012 NETL CO₂ Capture Technology Meeting, Pittsburgh, PA, July 2012. <http://www.netl.doe.gov/File%20Library/Research/Coal/ewr/CO2/enzymes-ultrasonics-july2012.pdf>.

Salmon, S., “Low-Energy Solvents for Carbon Dioxide Capture Enabled by a Combination of Enzymes and Ultrasonics,” Project kick-Off Meeting Presentation, November 2011. <http://www.netl.doe.gov/File%20Library/Research/Coal/ewr/CO2/enzymes-ultrasonics-kickoff-nov2011.pdf>.

DEVELOPMENT OF A NOVEL GAS-PRESSURED STRIPPING PROCESS-BASED TECHNOLOGY FOR CO₂ CAPTURE FROM POST-COMBUSTION FLUE GASES

primary project goals

Carbon Capture Scientific is performing bench-scale development, testing, and computer simulations of a novel solvent-based carbon dioxide (CO₂) capture technology, known as gas-pressurized stripping (GPS) process. The GPS technology has the potential to significantly reduce the energy penalty associated with solvent regeneration and compression by operating the regeneration step at higher pressures, which in-turn reduces the compression requirements for CO₂ storage.

technical goals

- Computer simulation to predict GPS column performance under different operating conditions.
- Lab-scale tests of individual process units to document experimental results and obtain necessary information to progress the technology to the next level;
- Experimental investigation of selected solvents to minimize the economic risk of the proposed technology;
- Design, build, and operate a bench-scale GPS unit capable of processing about 500 standard liters of actual coal-derived flue gas per minute (SLPM) at the National Carbon Capture Center (NCCC).

technical content

The project will conduct lab-scale individual process unit tests and integrated continuous bench-scale GPS system tests using actual coal-derived flue gas at the NCCC. The overall objective is to reduce the energy consumption and capital cost of the CO₂ capture process.

Computer simulation tasks will investigate the GPS column behavior under different operating conditions, optimizing the column design and operating conditions. Solvent related tasks will collect information on the solvent operating cost when a modified, commercially-available solvent is used in the GPS process. Experiment related tasks with the major individual units will obtain information needed for the bench-scale unit design, and the integrated continuous bench-scale GPS system tests using actual coal-derived flue gas at the NCCC will provide all the necessary information for the next level pilot-scale process and engineering design along with the GPS system performance data. Figure 1 is a flowchart for the GPS process. Table 1 lists the process parameters relevant to the GPS process.

technology maturity:

Bench-Scale, Real Flue Gas

project focus:

Gas-Pressurized Stripping

participant:

Carbon Capture Scientific

project number:

FE0007567

NETL project manager:

Andrew Jones
andrew.jones@netl.doe.gov

principal investigator:

Shiaoguo (Scott) Chen
Carbon Capture Scientific, LLC
scottchen@carboncapturescientific.com

partners:

CONSOL Energy, Inc.,
Nexant, Inc.,
Western Kentucky University

performance period:

10/1/11 – 6/30/15

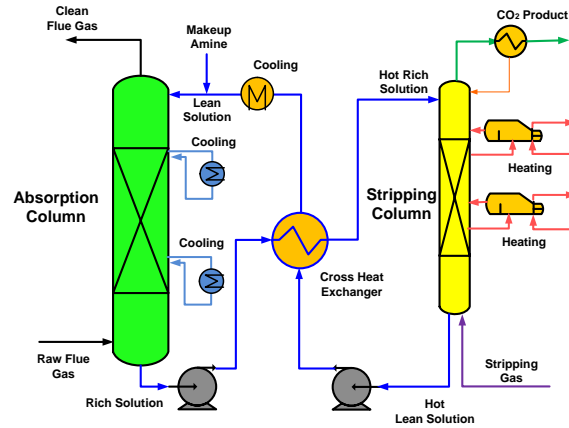

Figure 1: GPS-Based Absorption/Stripping Process

TABLE 1: PROCESS PARAMETERS

	Units	Current R&D Value	Target R&D Value
Pure Solvent			
Molecular Weight	mol ⁻¹	112.4	112.4
Normal Boiling Point	°C	226.8	226.8
Normal Freezing Point	°C	4.4	4.4
Vapor Pressure at 15 °C	bar	<1.3E-05	<1.3E-05
Manufacturing Cost for Solvent	\$/kg	3	3
Working Solution			
Concentration	%	50	50
Specific Gravity (15 °C/15 °C)	—	1.06	1.06
Specific Heat Capacity at STP	kJ/kg-K	ca. 3	ca. 3
Viscosity at STP	cP	N/A	
Absorption			
Pressure	bar	1.01	1.01
Temperature	°C	40	40
Equilibrium CO ₂ Loading	mol/mol	0.41	0.49
Heat of Absorption	kJ/mol CO ₂	59.6	59.6
Solution Viscosity	cP	6.2	4
Desorption			
Pressure	bar	6	6
Temperature	°C	120	120
Equilibrium CO ₂ Loading	mol/mol	0.19	0.19
Heat of Desorption	kJ/mol CO ₂	58.5	58.5
Proposed Module Design		<i>(for equipment developers)</i>	
Flue Gas Flowrate	kg/hr	40	
CO ₂ Recovery, Purity, and Pressure	%/%/bar	90%, >95%, 6 bar	
Absorber Pressure Drop	bar	0.05	

Definitions:

STP – Standard Temperature and Pressure (15 °C, 1 atm).

Pure Solvent – Chemical agent(s), working alone or as a component of a working solution, responsible for enhanced CO₂ absorption (e.g., the amine MEA in an aqueous solution).

Manufacturing Cost for Solvent – “Current” is market price of chemical, if applicable; “Target” is estimated manufacturing cost for new solvents, or the estimated cost of bulk manufacturing for existing solvents.

Working Solution – The solute-free (i.e., CO₂-free) liquid solution used as the working solvent in the absorption/desorption process (e.g., the liquid mixture of MEA and water).

Absorption – The conditions of interest for absorption are those that prevail at maximum solvent loading, which typically occurs at the bottom of the absorption column. These may be assumed to be 1 atm total flue-gas pressure (corresponding to a CO₂ partial pressure of 0.13 bar) and 40 °C; however, measured data at other conditions are preferable to estimated data.

Desorption – The conditions of interest for desorption are those that prevail at minimum solvent loading, which typically occurs at the bottom of the desorption column. Operating pressure and temperature for the desorber/stripper are process-dependent (e.g., an MEA-based absorption system has a typical CO₂ partial pressure of 1.8 bar and a reboiler temperature of 120 °C). Measured data at other conditions are preferable to estimated data.

Pressure – The pressure of CO₂ in equilibrium with the solution. If the vapor phase is pure CO₂, this is the total pressure; if it is a mixture of gases, this is the partial pressure of CO₂. Note that for a typical PC power plant, the total pressure of the flue gas is about 1 atm and the concentration of CO₂ is about 13.2 percent. Therefore, the partial pressure of CO₂ is roughly 0.132 atm or 0.130 bar.

Concentration – Mass fraction of pure solvent in working solution.

Loading – The basis for CO₂ loadings is moles of pure solvent.

Other Parameter Descriptions:

Chemical/Physical Solvent Mechanism – Pressurized stripping is a process applicable to different types of solvents. Chemistry of the GPS-based absorption/stripping process depends on the solvent used in the process. In the proposed research, a modified commercially-available amine solvent will be used. Therefore, the chemistry of the amine-based CO₂ capture process will apply to the GPS-based process.

The reaction kinetics of the GPS-based process also depends on the solvent selected. With the solvent currently selected, it is believed that the reaction kinetics of the modified commercially available solvent will perform better than the baseline monoethanolamine (MEA) process.

Solvent Contaminant Resistance – Since the selected solvent is an amine-based solvent, it will share common issues that other amine-based solvents have. Sulfur oxide (SO_x) and nitrogen oxide (NO_x) could be the major contaminants in flue gas, which will be detrimental to all amine-based solvents, including the solvent used in this process. Similar to other amine-based solvents, pretreatment of flue gas will be required to minimize amine degradations.

Solvent Foaming Tendency – The solvent is a commercially available solvent, with different strength. The solvent forming tendency should be manageable based on industrial experience.

Flue Gas Pretreatment Requirements – Similar to other amine-based solvents, pretreatment of flue gas will be required to minimize amine degradations.

Solvent Makeup Requirements – Solvent stability study has demonstrated that this commercially-available solvent will have solvent makeup rate of 1 kg solvent/tonne CO₂.

Waste Streams Generated – Waste stream of the GPS-based process is also similar to other amine-based absorption/stripping processes. The main waste material is amine degradation products.

Process Design Concept – Flowsheet/block flow diagram of the GPS process is shown in Figure 1. It is clear that the GPS process is virtually the same as a conventional absorption/stripping process except the two unique innovations: (1) using two side heat exchangers to replace a bottom reboiler, and (2) introducing a stripping gas (N₂ or other inert gas) into the GPS column from the bottom. This process configuration will reduce stripping heat significantly.

Proposed Module Design – Unless noted, flue gas feed pressure is 1.014 bara, temperature is 57 °C, and composition leaving the flue gas desulfurization (FGD) unit (wet basis) should be assumed:

Composition (% vol)					Composition (ppmv)	
CO ₂	H ₂ O	N ₂	O ₂	Ar	SO _x	NO _x
13.17	17.25	66.44	2.34	0.80	42	74

technology advantages

- The use of off-the-shelf process equipment will accelerate process development.
- The use of absorption/stripping technology would be suitable for low-cost, large-scale applications.
- The higher stripper operating pressure reduces the stripping heat requirement and subsequent compression work. As a result, GPS process offers higher energy efficiency.
- The GPS technology is flexible in terms of operating pressures and temperatures, and is applicable to different types of solvents.

R&D challenges

The major challenge of the GPS-based process is its capital cost. The optimal GPS-based process has almost the same capital cost as the baseline process. New process equipment, which can significantly reduce capital cost, is needed to commercialize the GPS technology.

results to date/accomplishments

- Computer simulation achieved GPS column thermal efficiency of 79 percent.
- Computer simulations indicated that overall process energy performance of 0.20 kWh/kgCO₂.
- GPS column tests demonstrated that the thermal efficiency of the GPS column can achieve over 70 percent.
- Thermal stability of the selected solvent has been tested and solvent loss was found to be lower than 1 kg/ton CO₂.
- Oxidative stability tests of the solvent have been completed and the results showed negligible oxidative degradation.
- Corrosiveness of the selected solvent was tested at high loading and high temperature.
- Completed all major individual process unit tests at lab to validate applicability to post-combustion CO₂ capture.
- Parametric tests at the NCCC have demonstrated that the GPS process can achieve 90 percent CO₂ capture with 95 percent CO₂ purity while desorbing the CO₂ at high-pressure (6 bar) with nitrogen stripping gas.
- A preliminary techno-economic analysis has been conducted and the results showed that a levelized cost-of-electricity (LCOE) increase of 52 percent over the baseline can be achieved.

next steps

- Refine the techno-economic analysis of the GPS system using updated data.
- Conduct long-term ($\approx 2,000$ hours) steady-state tests of the bench-scale GPS unit at NCCC to obtain solvent performance data.

available reports/technical papers/presentations

Shiaoguo (Scott) Chen, “Development of a Novel Gas Pressurized Stripping (GPS)-Based Technology for CO₂ Capture from Post-Combustion Flue Gases,” 2014 NETL CO₂ Capture Technology Meeting, Pittsburgh, PA, July 2014.

<http://www.netl.doe.gov/File%20Library/Events/2014/2014%20NETL%20CO2%20Capture/S-Chen-CCS-Development-Of-A-Novel-Gas-Pressurized-Stripping.pdf>.

Shiaoguo (Scott) Chen, “Development of a Novel Gas Pressurized Stripping (GPS)-Based Technology for CO₂ Capture from Post-Combustion Flue Gases,” 2013 NETL CO₂ Capture Technology Meeting, Pittsburgh, PA, July 2013.

<http://www.netl.doe.gov/File%20Library/Events/2013/CO2%20Capture/S-Chen-CCS-Novel-GPS-Based-Technology.pdf>.

Shiaoguo (Scott) Chen, “Preliminary Technical and Economic Feasibility Study—Topical Report,” October 2012.

<http://www.netl.doe.gov/File%20Library/Research/Coal/ewr/CO2/FE0007567-Topical-Report-10-30-12.pdf>.

Shiaoguo (Scott) Chen, “Development of a Novel Gas Pressurized Stripping (GPS)-Based Technology for CO₂ Capture from Post-Combustion Flue Gases,” 2012 NETL CO₂ Capture Technology Meeting, Pittsburgh, PA, July 2012.

<http://www.netl.doe.gov/File%20Library/Research/Coal/ewr/CO2/development-novel-gas-pressurized-stripping-july2012.pdf>.

“Development of a Novel Gas Pressurized Stripping Process-Based Technology for CO₂ Capture,” Project Kick-Off Meeting Presentation, November 2011. <http://www.netl.doe.gov/File%20Library/Research/Coal/ewr/CO2/development-novel-gas-pressurized-stripping-kickoff-nov2011.pdf>.

CARBON ABSORBER RETROFIT EQUIPMENT (CARE)

primary project goals

Neumann Systems Group, Inc. (NSG) is designing, constructing, and testing a 0.5-MW scale patented NeuStream[®] absorber at the Colorado Springs Utilities (CSU) Martin Drake #7 power plant. The absorber will employ nozzle technology proven during a recently completed 20-MW NeuStream-S flue gas desulfurization (FGD) pilot project, as well as a 6-m piperazine (PZ) solvent, which is an efficient solvent for capturing carbon dioxide (CO₂).

Due to an unrelated turbine fire at the Martin Drake plant in May of 2014, the project scope was revised to relocate the system to NSG's facility, where a natural gas steam boiler will provide the flue gas and stripping heat. Stripped CO₂ will be recycled to increase the incoming CO₂ concentration to ≈13 percent to simulate flue gas from a coal-fired boiler.

technical goals

- Design a 0.5-MWe slipstream CO₂ scrubber that will minimize parasitic power through efficient design.
- Demonstrate a 2-month steady-state operation with a three-stage absorber and a multistage stripper.
- Demonstrate 90 percent CO₂ capture efficiency utilizing the best available solvent.
- Show unit traceability/scalability to commercial scale.

technical content

The NSG Carbon Absorber Retrofit Equipment (CARE) project includes design, construction, and testing of a 0.5MW NeuStream[®] CO₂ capture system, based on NSG's patented flat jet, modular absorber technology. The NeuStream[®] absorber uses a proven technology with an array of flat jets and an advanced solvent (6 m PZ) to capture CO₂. The CARE absorber design is based on modeling (computational fluid dynamics [CFD] and Aspen Plus) and analysis of carbon capture data from slipstream experiments, where experimental specific surface areas of 440 m²/m³ have been achieved. The CARE system slipstream test includes compact NeuStream[®] modules, as well as sulfur oxide (SO_x) scrubbing and amine washing equipment that also utilizes the NeuStream[®] flat jet technology.

The SO_x scrubbing equipment uses compact modular NeuStream[®] technology and can be adjusted to residual SO_x level (1–30 parts per million [ppm]) prior to CO₂ capture. The CARE project employs slipstream nitrogen oxide (NO_x) removal; a four-stage, 0.5-MWe NeuStream[®] high-performance absorber unit for scrubbing; a novel stripper design that reduces heat waste; and a flue gas heat-recovery method to offset a portion of steam usage.

technology maturity:

Pilot-Scale, Actual Flue Gas Slipstream

project focus:

Carbon Absorber Retrofit Equipment

participant:

Neumann Systems Group

project number:

FE0007528

NETL project manager:

Andy O'Palko
andrew.opalko@netl.doe.gov

principal investigator:

Eric Klein
Neumann Systems Group
erick@neumannsystemsgroup.com

partners:

Colorado Springs Utilities
UNDEERC
Industrial Constructor
Managers
University of Texas

performance period:

1/2/12 – 1/31/15

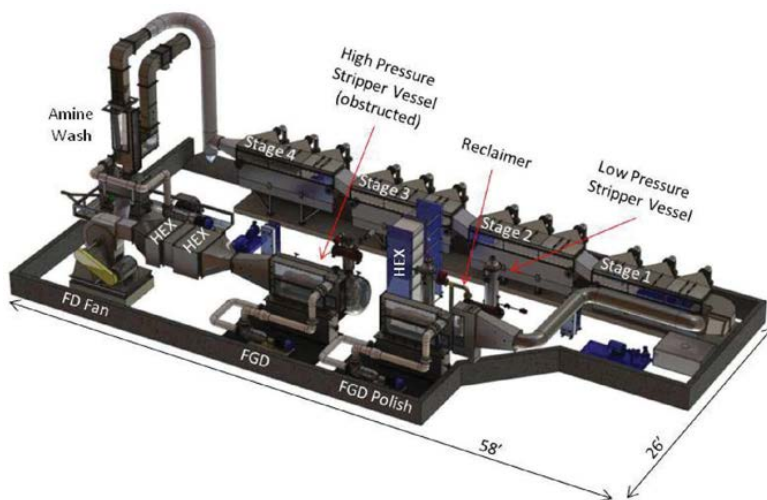

Figure 1: The System Layout of the 0.5-MW NeuStream®-C Demonstrator System

TABLE 1: PROCESS PARAMETERS

	Units	Current R&D Value ^[1,2]	Target R&D Value
Pure Solvent (Piperazine)			
Molecular Weight	mol ⁻¹	86.14	86.14
Normal Boiling Point	°C	146	146
Normal Freezing Point	°C	106	106
Vapor Pressure at 15 °C	bar	<0.001	<0.001
Manufacturing Cost for Solvent	\$/kg	—	—
Working Solution*			
Concentration	kg/kg	34%	34%
Specific Gravity (15 °C/15 °C)	—	0.99 (50°C)	0.99 (50°C)
Specific Heat Capacity at STP	kJ/kg-K	3.6 (50°C)	3.6 (50°C)
Viscosity at STP	cP	3.6 cP at 50 C	3.6 cP at 50°C
Absorption			
Pressure**	bar	0.101	0.101
Temperature	°C	40	40
Equilibrium CO ₂ Loading	mol/mol	0.38	0.38
Heat of Absorption	kJ/mol CO ₂	73	73
Solution Viscosity	cP	4.7	4.7
Desorption			
Pressure***	bar	2/4	2/4
Temperature	°C	150	150
Equilibrium CO ₂ Loading	mol/mol	0.28	0.28
Heat of Desorption	kJ/mol CO ₂	73	73
Proposed Module Design		<i>(for equipment developers)</i>	
Flue Gas Flowrate	kg/hr	2,370	
CO ₂ Recovery, Purity, and Pressure	%/%/bar	90%, >95%, 4/8 bar	

*unloaded PZ solution is a solid at 15 °C; **CO₂ partial pressure in the flue gas at Drake plant; ***CO₂ partial pressure exiting stripper

Definitions:

STP – Standard Temperature and Pressure (15 °C, 1 atm).

Pure Solvent – Chemical agent(s), working alone or as a component of a working solution, responsible for enhanced CO₂ absorption (e.g., the amine monoethanolamine [MEA] in an aqueous solution).

Manufacturing Cost for Solvent – “Current” is market price of chemical, if applicable; “Target” is estimated manufacturing cost for new solvents, or the estimated cost of bulk manufacturing for existing solvents.

Working Solution – The solute-free (i.e., CO₂-free) liquid solution used as the working solvent in the absorption/desorption process (e.g., the liquid mixture of MEA and water).

Absorption – The conditions of interest for absorption are those that prevail at maximum solvent loading, which typically occurs at the bottom of the absorption column. These may be assumed to be 1 atm total flue gas pressure (corresponding to a CO₂ partial pressure of 0.13 bar) and 40 °C; however, measured data at other conditions are preferable to estimated data.

Desorption – The conditions of interest for desorption are those that prevail at minimum solvent loading, which typically occurs at the bottom of the desorption column. Operating pressure and temperature for the desorber/stripper are process-dependent (e.g., an MEA-based absorption system has a typical CO₂ partial pressure of 1.8 bar and a reboiler temperature of 120 °C). Measured data at other conditions are preferable to estimated data.

Pressure – The pressure of CO₂ in equilibrium with the solution. If the vapor phase is pure CO₂, this is the total pressure; if it is a mixture of gases, this is the partial pressure of CO₂. Note that for a typical pulverized coal (PC) power plant, the total pressure of the flue gas is about 1 atm and the concentration of CO₂ is about 13.2 percent. Therefore, the partial pressure of CO₂ is roughly 0.132 atm or 0.130 bar.

Concentration – Mass fraction of pure solvent in working solution.

Loading – The basis for CO₂ loadings is moles of pure solvent.

Other Parameter Descriptions:

Chemical/Physical Solvent Mechanism – The absorption of CO₂ into concentrated PZ follows a carbamate mechanism, which is typical of primary and secondary amines. The overall chemical reaction of PZ with CO₂ is shown in Eq. 1, while the full aqueous reaction pathway is shown in Eqs. 2- 8.^[3]

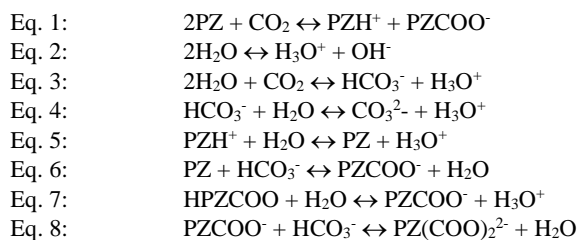

Solvent Contaminant Resistance – 6-m PZ is thermally stable at 150 °C with negligible oxidative degradation. The total amine loss is estimated to be 0.4 percent/week when stripping at 150 °C. At 135 °C, the reported thermal degradation of PZ is 0.07 percent as compared to 8.1 percent in the case of an MEA solvent.^[4] The main degradation products of PZ are nitrates (0.13 mM/hr) and ethylenediamine (0.09 mM/hr).

Flue Gas Pretreatment Requirements – The flue gas is passed through a NeuStream® NO_x- and SO_x-removal system before being fed to the CARE system. The SO_x concentration is kept below 10 ppm using two stages of NeuStream® FGD absorbers. The polishing scrubber for SO_x removal has a high volumetric mass-transfer coefficient and 90 percent removal efficiency. The polishing scrubber also cools the flue gas from 57 °C to ≈32 °C by contacting the flue gas with cold sorbent. This helps maintain water balance while also reducing the volumetric flow rate through the CO₂ absorber and counteracting some of the heat from the exothermic CO₂ absorption reaction, reducing the PZ solvent temperature and decreasing the equilibrium vapor pressure, both of which help to reduce the size of the CO₂ absorber.

Waste Streams Generated – Solid waste streams are generated by the reclaimers, which removes heat stable salts formed by NO_x and SO₂ absorption, and by the inline filters. Fugitive liquid amine emissions will be controlled by incorporating seamless valves, rupture disks, closed-loop ventilation systems, pumps with dual mechanical seals, minimum welds, and correct gasket material selection. Amine slip is minimized through the use of an amine water wash absorber unit, also based on NeuStream® technology. The FGD unit generates a gypsum by-product suitable for landfill.

Process Design Concept – Process flow diagram is shown in Figure 2 below.

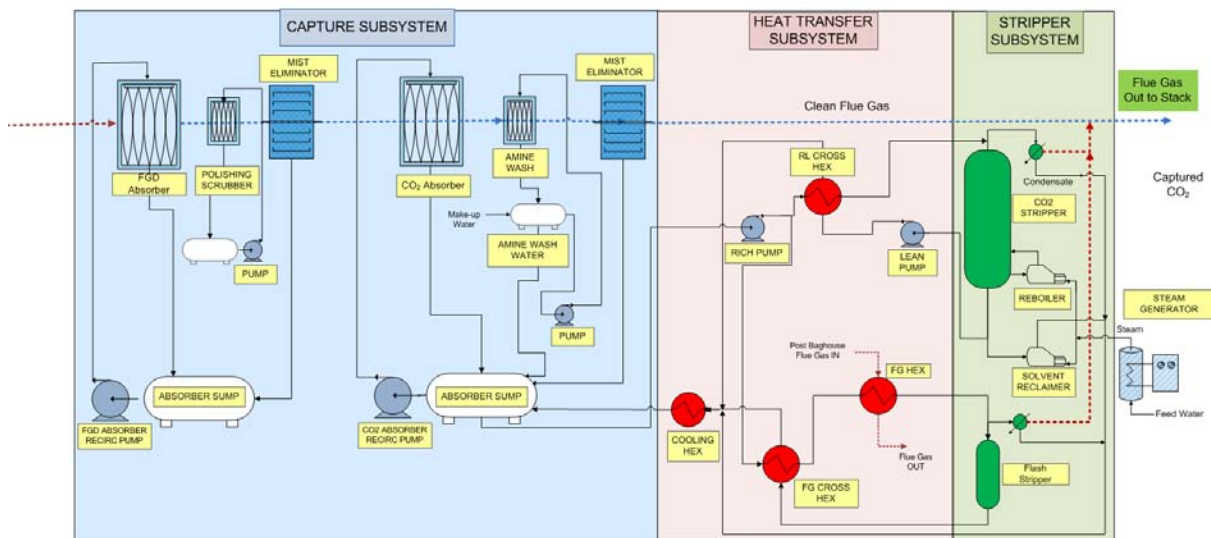

Figure 2: Process Flow Diagram of CARE System

Proposed Module Design – The heart of the NeuStream® system is NSG’s patented, high specific surface area NeuStream® flat jet nozzle technology (shown in Figure 3) engineered into modular, scalable, and efficient cross-flow gas liquid contactor (absorber) units. The modular absorber units are arranged in parallel into full scale systems. Several areas of innovation make this gas-liquid contactor extremely effective for absorbing CO₂ from flue gas. First, a high specific surface area (400 – 800 m⁻¹) absorption zone is achieved over a large volume from an array of flat jets driven by low liquid-side pressure (< 34kPa). Secondly, the flat jets are aerodynamically shaped which allows for a high gas flow parallel to the jets while maintaining a low gas-side pressure drop (0.25 kPa/m). Packaging of the NeuStream® absorber takes advantage of the high specific surface area and high gas velocities (typically 5 m/s for CO₂ capture) to reduce the footprint of the system by up to 90 percent and booster fan power requirements by up to 70 percent when compared to conventional packed towers.

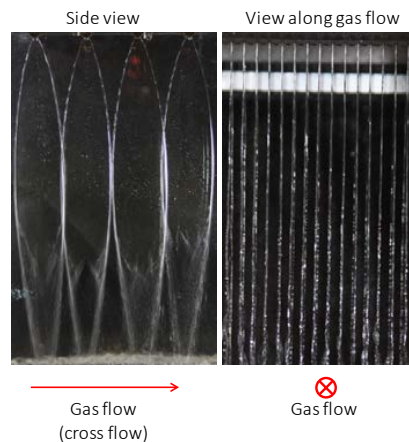

Figure 3: NeuStream® Flat Jet Technology

The system layout is shown above in Figure 1 and the process flow diagram is shown above in Figure 2, where Ozone is introduced upstream of a forced draft to oxidize NO_x to more soluble components. The fan moves the flue gas through a heat exchanger to heat the slipstream flow back up to a representative temperature (350 °F). The flue gas then passes through a second heat exchanger, which heats loaded solvent and reduces steam usage in the regeneration subsystem. The flue gas then passes through a NeuStream® FGD system to reduce the SO_x concentration to 15 ppm and the NO_x by 80–90 percent. A polishing/direct contact cooler (DCC) NeuStream® scrubber is used to further reduce the SO_x to 1 ppm, and to cool the flue gas to <35 °C. After the polishing/DDC scrubber, the gas passes through a four-unit NeuStream® CO_2 absorber (shown in Figure 4), where each unit has three stages. This 12-stage absorber reduces the CO_2 by 90 percent prior to contacting the flue gas with a NeuStream® amine wash, which cleans the amine slip from the gas before reintroducing it into the plant's main flue gas stream. Due to space constraints, only 3 of the 4 absorber units were relocated to NSG's facility following the unrelated turbine fire at the Drake plant, such that the expected capture efficiency at design gas flow rates would decrease from 90 percent to ≈ 75 percent and the gas flow would need to be derated in order to realize 90 percent CO_2 capture.

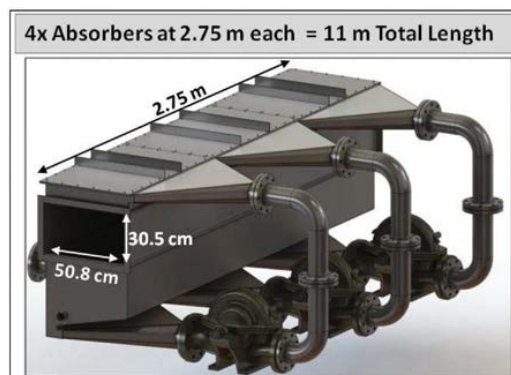

Figure 4: Solid Model of One of Four NeuStream® CO_2 Absorber Stages Utilized in Project CARE
(Cross sectional area scales with system size, but length remains unchanged.)

The regeneration system contains all typical components, such as cross heat exchangers, solvent cooler exchanger, rich pump, reclaiming, and condenser. A custom-designed stripper vessel is utilized in expectation of lowering steam usage during operation. Additionally, approximately 10 percent of the rich flow is directed to a lower-pressure flash vessel to desorb the CO_2 from the solvent using only heat provided by the flue gas.

technology advantages

- The NeuStream® CO_2 capture technology integrates a highly-efficient, compact absorber design with an advanced solvent, leading to substantial (≈ 90 percent) reduction in absorber volume as well as significant savings in both capital and operating costs compared to conventional systems.
- The high surface areas of the NeuStream® flat jets and low-pressure drop in the absorber lower the capital cost of the absorber considerably, leading to significant reductions in the increase in levelized cost of electricity (LCOE) over MEA.
- The NeuStream® technology is adaptable to a wide range of solvents encompassing a large spectrum of properties such as surface tension, viscosity and mass transfer rates.
- The NeuStream® flat jets are engineered into modular absorber units which are arranged in parallel to meet the flue gas flow rate requirements for specific applications, facilitating rapid, low-risk scale-up of the technology.
- The NeuStream® technology incorporates PZ regeneration at high pressures, leading to lower CO_2 compression power requirements.
- The CARE system utilizes an alternative NO_x -removal strategy to demonstrate the viability of this option over selective catalytic reductions (SCRs).
- The CARE system utilizes a flue gas heat-recovery strategy to reduce the steam usage in the regeneration subsystem.
- A novel stripper design developed by NSG with Dr. Rochelle and Dr. Chen at the University of Texas is incorporated into the CARE system in an attempt to minimize steam usage.

R&D challenges

- Ensuring optimal distribution of gas in the absorber and avoiding gas bypassing the jets in large-scale absorbers may be an issue which is addressed via CFD modeling.
- Results from tests on the design verification stand indicate that the specific surface area is not fully preserved with increasing jet length; this may lead to larger absorbers, increasing capital costs. It is possible this decrease is due to the wall effects that become more prevalent at longer jet lengths in the design verification test stand.

results to date/accomplishments

- Results from the Energy and Environmental Research Center (EERC) tests using a flue gas flow rate of 160 standard cubic feet per minute (SCFM) demonstrated high specific surface areas of $300 \text{ m}^2/\text{m}^3$ with low-system pressure-drop (0.25 kPa/m) with high CO_2 capture efficiencies (up to 83 percent).
- Techno-economic analysis of the NeuStream[®]-C by EERC indicated that the increase in LCOE over a subcritical power plant without CO_2 capture would be approximately 40 percent and the cost of CO_2 capture is at $\$25.73/\text{tonne}$.
- A design verification and testing (DVT) stand (300–2,200 SCFM gas flow rate) was used to validate the preliminary design of the 0.5-MW CARE unit (absorber, pumps, heat exchangers, strippers) and was completed by NSG.
- Investigations of the effects of jet length, gas velocity, nozzle spacing, and nozzle pressure on the CO_2 capture efficiency and the rate of CO_2 absorption in the DVT stand demonstrated high surface areas ($300\text{--}450 \text{ m}^2/\text{m}^3$) for 22- to 12-inch long jets, respectively.
- Prior to the turbine fire at the Martin Drake plant, shake-out and acceptance testing was completed, parametric testing was started and initial steady-state operation was achieved on coal flue gas. Lean and rich solvent loadings were measured to be 0.282 and 0.365 respectively compared to the design point of 0.28 and 0.38, and CO_2 capture efficiency was determined to be 89.9 percent as compared to the design point of 90 percent.
- Pilot-system location was moved to NSG (due to turbine fire at CSU's Martin Drake facility); construction of a simplified system with no FGD, no NO_x control, no flue gas heat integration, and only using three-quarters of the absorbers was completed.
- Extensive testing of the CARE system at NSG's facility included a one week continuous 24x7 run. At the 5 m/s gas velocity design point, CO_2 capture efficiency was about 75 percent (as expected due to 3 vs. 4 absorber units). As expected, reduced gas velocity of 3 m/s ($\approx 0.3 \text{ MW}$) increased the capture efficiency back to the 90 percent design point. Average specific surface area was measured to be $435 \text{ m}^2/\text{m}^3$ at 5 m/s, slightly higher than the $425 \text{ m}^2/\text{m}^3$ design value. See Figure 5 below.

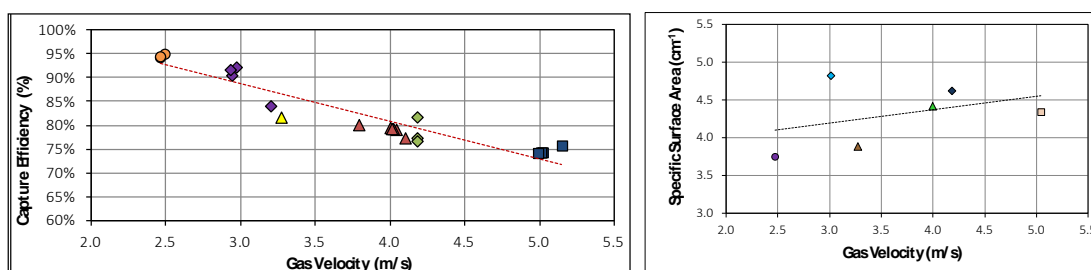

Figure 5: NeuStream[®] CARE capture efficiency (left) and specific surface area, a_s in cm^2/cm^3 (right)

next steps

Project complete as of January 31, 15.

available reports/technical papers/presentations

“Progress Update on the Carbon Dioxide Absorber Retrofit Equipment (CARE) Program,” 2014 NETL CO₂ Capture Technology Meeting, July 2014. <http://www.netl.doe.gov/File%20Library/Events/2014/2014%20NETL%20CO2%20Capture/A-Awtry-NSG-Progress-Update-On-NSGs-CARE.pdf>.

“Status of the Carbon Dioxide Absorber Retrofit Equipment (CARE) Program,” 2013 NETL CO₂ Capture Technology Meeting, July 2013. <http://www.netl.doe.gov/File%20Library/Events/2013/CO2%20Capture/A-Awtry-NSG-Status-of-the-CARE-Program.pdf>.

Brasseur, J., and Awtry, A., “Compact Absorber Retrofit Equipment (CARE),” presented at the 2012 NETL CO₂ Capture Technology Meeting, July 2012, Pittsburgh, PA.

<http://www.netl.doe.gov/publications/proceedings/12/CO2capture/presentations/2-Tuesday/2-Brasseur-NeumannSG.pdf>.

Awtry, A., Klein, E., and Brasseur, J., “NeuStream[®]-C: Carbon Capture Progress Update”, Air Quality IX, Arlington, VA, 2013.

Awtry, A., Klein, E., and Brasseur, J., “NeuStream[®]-C: Carbon Capture Progress Update”, Power-Gen XXV, Orlando, FL, 2013.

references

^[1]Dugas, Ross E., “CO₂ Absorption, Desorption, and Diffusion in Aqueous Piperazine and Monoethanolamine,” PhD Thesis, University of Texas, 2009.

^[2]Van Wagener, David H., “Stripper Modeling for CO₂ Removal Using Monoethanolamine and Piperazine Solvents,” PhD Thesis, University of Texas, 2011.

^[3]Bishnoi, S., and Rochelle, G. T., “Absorption of carbon dioxide into aqueous piperazine: reaction kinetics, mass transfer and solubility,” *Chemical Engineering Science* 55 (2000) 5531-5543.

^[4]Dombrowski, K., “Evaluation of Concentrated Piperazine for CO₂ Capture from Coal-Fired Flue Gas,” DOE-NETL Contractor’s Meeting, 2010.

DEVELOPMENT OF AN ENERGY-EFFICIENT, ENVIRONMENTALLY FRIENDLY SOLVENT FOR THE CAPTURE OF CO₂

primary project goals

This Babcock & Wilcox Power Generation Group, Inc., (B&W) project focuses on identifying concentrated piperazine (PZ)-based solvent formulations that improve overall solvent and system performance.

technical goals

- Improve system operability and reliability.
- Minimize environmental impacts.
- Reduce corrosion potential.
- Maximize solvent durability.

technical content

B&W is characterizing and optimizing the formulation of a novel solvent for the capture of carbon dioxide (CO₂) at coal-fired utility plants. The solvent of interest has been identified through a 5-year solvent development program conducted at B&W. The solvent formulations of interest comprise concentrated solutions of a cyclic diamine, PZ. Testing at B&W indicates that blends of concentrated PZ with other compounds have the potential to perform substantially better than PZ itself. The objective is to lower the total cost of solvent-based CO₂ capture systems by identifying formulations that improve overall solvent and system performance.

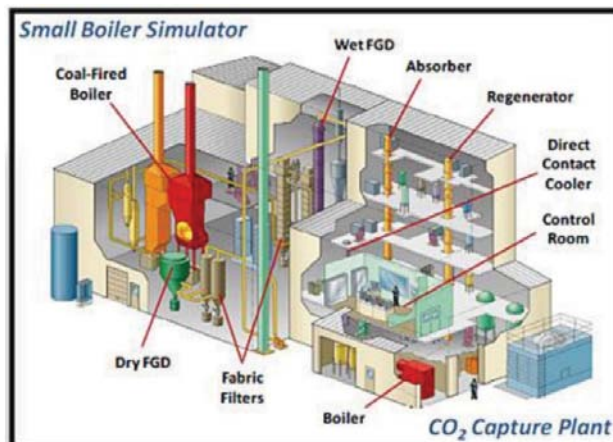

Figure 1: B&W 7-Ton/Day Pilot Facility

technology maturity:

Bench-Scale, Simulated and Actual Flue Gas

project focus:

Optimized Solvent Formulation

participant:

Babcock & Wilcox

project number:

FE0007716

NETL project manager:

Bruce Lani

bruce.lani@netl.doe.gov

principal investigator:

George Farthing

Babcock & Wilcox

gafarthing@babcock.com

partners:

University of Cincinnati,
First Energy

performance period:

10/1/11 – 4/30/14

Other Parameter Descriptions:

Chemical/Physical Solvent Mechanism – The CO₂-reactive species (there may be other non-reactive species) in the solvent formulation may include amines, carbonates, or amino acid salts in combination with concentrated PZ. Amine solvents are grouped according to their molecular structure. Carbonate and amine reactions with CO₂ can be summarized as follows:

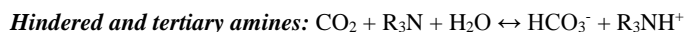

Solvent Contaminant Resistance – Amine solvents chemically degrade in a variety of ways (thermal degradation due to exposure to the high temperatures of the regeneration process, oxidative degradation due to the presence of oxygen in the flue gas, carbamate polymerization, etc.). Degradation reactions can be accelerated by the presence of degradation or corrosion products and heat-stable salts, and through the catalytic effects of various metals (possibly originating with the coal fly ash). Minimizing solvent degradation and the attendant production of potentially hazardous chemical species is a central objective of this project.

Flue Gas Pretreatment Requirements – Flue gas supplied to the CO₂ capture system must be cooled to approximately 40°C and relatively free of contaminants. Concentrations of sulfur dioxide (SO₂) and nitrogen dioxide (NO₂) must be less than about 10 parts per million (ppm)—preferably around 1 ppm.

Solvent Makeup Requirements – Solvent makeup is required to offset solvent losses due to volatility, degradation, the formation of heat stable salts, etc. PZ-based solvents are expected to minimize such losses due to the lower volatility and better resistance to thermal degradation exhibited by PZ relative to solvents such as monoethanolamine (MEA). This project is focused on minimizing solvent losses in the system.

Waste Streams Generated – Waste streams generated by the process will be similar to those generated by convention amine processes, including reclaimer waste solids, spent carbon and particulate filter cake from solvent filtration equipment, and potentially waste water. It is an objective of this project to minimize the environmental impact of these streams through careful selection of the solvent formulation and operating conditions.

Process Design Concept – The CO₂ capture process, illustrated in Figure 2, comprises a relatively conventional absorption/stripping process.

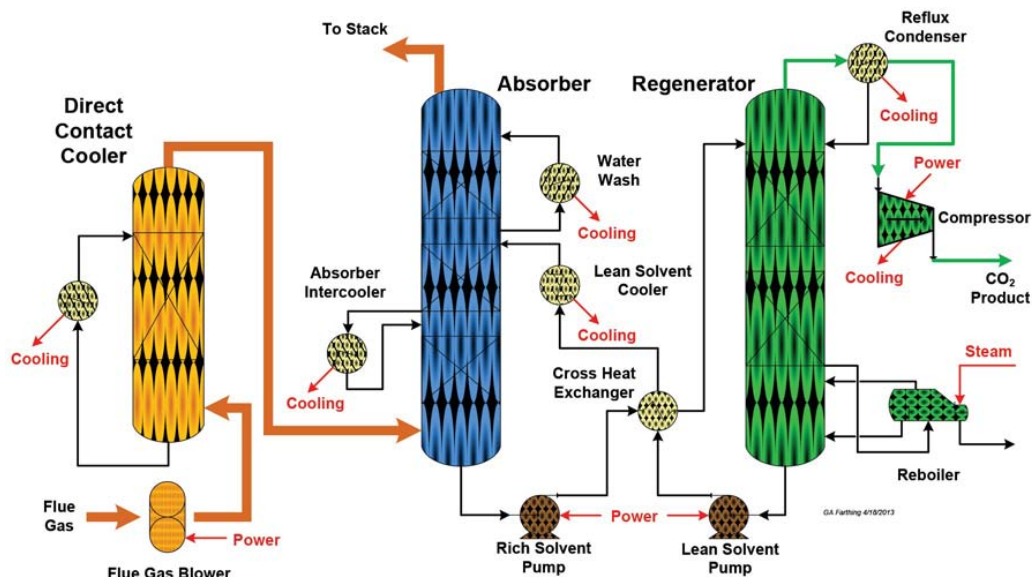

Figure 2: Schematic of Solvent-Based CO₂ Capture Process

technology advantages

Piperazine, used alone, has demonstrated high rates of absorption and low regeneration energy. Recent testing at B&W indicates that blends of concentrated PZ with other organic compounds may perform substantially better than PZ alone.

R&D challenges

- Selection of a solvent formulation involves compromises that seek to optimally balance competing effects. Using limited and potentially non-representative data generated in laboratory-scale equipment is extremely challenging. Previous solvent development work supports correlation of laboratory results with pilot-scale performance estimation to optimize solvent formulation.
- Goals include improved system operability and reliability, minimizing environmental impacts, reducing corrosion potential, and maximizing solvent durability.

results to date/accomplishments

- A list of candidate solvent formulations was developed and refined. This work comprised evaluations regarding overall solvent performance criteria, identification of primary active components, and verification of wet chemistry analytical techniques for CO₂ loading and alkalinity.
- Several modeling approaches were identified. Tools considered include equilibrium models, semi-empirical rate-based models, and rigorous rate-based models. Tools for the prediction of process economics were also evaluated.
- Characterization tests in B&W's wetted-wall column (WWC) were completed on a baseline concentrated PZ solvent and 12 candidate solvent formulations. The liquid film mass transfer coefficient (k_g), as well as equilibrium partial pressure of CO₂ ($P_{CO_2^*}$), were obtained from each WWC test. Other parameters, such as heat of absorption and CO₂ working capacity, were also derived from these experimental data. Preliminary solvent formulation performance was then estimated with in-house, semi-empirical models.
- Solvent volatility and solubility testing was performed on several candidate formulations of concentrated PZ solutions containing salts of amino acids, carbonates, and other amines. Also evaluated were organic additives designed to improve the solubility of PZ and its carbamates. In addition, it was found necessary to characterize candidate formulations with respect to their viscosities in order to ensure good mass transfer performance and acceptable operability.
- Installation of the bench-scale continuous solvent degradation system (CSDS) was completed. The CSDS will enable comprehensive investigations of proposed solvent formulation degradation under representative operating conditions. It is intended to simulate key features of industrial CO₂ capture processes, including cyclical absorption and regeneration process conditions. The CSDS is designed for continuous, unattended operation for tests lasting 100 to 1,000 hours or more.

next steps

This project ended on April 30, 2013.

available reports/technical papers/presentations

Final Report, "Optimized Solvent for Energy-Efficient, Environmentally Friendly Capture of CO₂ at Coal-Fired Power Plants," June 2014. <http://www.osti.gov/scitech/servlets/purl/1136527>.

Farthing, G., "Optimized Solvent for Energy-Efficient, Environmentally Friendly Capture of CO₂ at Coal-Fired Power Plants," presented at the 2012 NETL CO₂ Capture Technology Meeting, Pittsburgh, PA, July 2012.

BENCH-SCALE DEVELOPMENT OF A HOT CARBONATE ABSORPTION PROCESS WITH CRYSTALLIZATION-ENABLED HIGH-PRESSURE STRIPPING FOR POST-COMBUSTION CO₂ CAPTURE

primary project goals

The University of Illinois at Urbana-Champaign (UIUC) is performing a proof-of-concept study that will generate process engineering and scaleup data to optimize the Hot Carbonate Absorption Process (Hot-CAP) with crystallization-enabled, high-pressure stripping technology. The study seeks to demonstrate its capability to achieve the U.S. Department of Energy (DOE) goals of at least 90 percent carbon dioxide (CO₂) removal from coal-fired power plant flue gas with less than a 35 percent increase in the cost of electricity (COE), helping to advance the process to pilot-scale level within 3 years.

technical goals

- Perform laboratory- and bench-scale tests to measure thermodynamic and reaction engineering data that will be used to evaluate technical feasibility and cost-effectiveness, performance of scaleup, and commercial competitiveness of the Hot-CAP with monoethanolamine (MEA)-based processes and other emerging post-combustion CO₂ capture technologies.
- Perform a combination of experimental, modeling, process simulation, and technical and economic analysis studies.

technical content

UIUC and Carbon Capture Scientific, LLC are investigating a Hot-CAP to overcome the energy use disadvantage of MEA-based processes. A preliminary technical-economic evaluation shows that the energy use of the Hot-CAP is about 40 percent less than that of its MEA counterpart, and the process has the potential to meet or exceed DOE's technical and cost goals of greater than or equal to 90 percent CO₂ removal and less than or equal to a 35 percent increase in the COE.

The Hot-CAP is an absorption-based, post-combustion CO₂ technology that uses a carbonate salt (K₂CO₃ or Na₂CO₃) as a solvent. The process integrates a high-temperature (70–80 °C) CO₂ absorption column, a slurry-based high-pressure (up to 40 atm) CO₂ stripping column, a crystallization unit to separate bicarbonate and recover the carbonate solvent, and a reclaimer to recover CaSO₄ as the byproduct of the sulfur dioxide (SO₂) removal.

technology maturity:

Laboratory-Scale,
Simulated Flue Gas

project focus:

Hot Carbonate Absorption
with Crystallization-
Enabled High-Pressure
Stripping

participant:

University of Illinois at
Urbana-Champaign

project number:

FE0004360

NETL project manager:

Andrew Jones
andrew.jones@netl.doe.gov

principal investigator:

Yongqi Lu
University of Illinois at
Urbana-Champaign
yongqilu@illinois.edu

partners:

Carbon Capture
Scientific, LLC

performance period:

1/1/11 – 3/31/14

Project objectives include performing a proof-of-concept study aimed at generating process engineering and scaleup data to help advance the Hot-CAP technology to pilot-scale demonstration level. The project tasks employ lab- and bench-scale test facilities to measure thermodynamic and reaction engineering data that can help evaluate technical feasibility and cost-effectiveness, performance of scaleup, and commercial competitiveness of the Hot-CAP compared to the MEA-based processes and other emerging post-combustion CO₂ capture technologies.

To meet project objectives, lab- and bench-scale tests include measurement of the kinetics and phase equilibrium data associated with the major reactions and unit operations in the Hot-CAP, including CO₂ absorption, bicarbonate crystallization, sulfate recovery, and CO₂ stripping. The results from the lab- and bench-scale studies support development of a process flow diagram, equipment and process simulations, and a techno-economic study for a conceptual 550-MWe high-sulfur coal-fired power plant retrofitted with the Hot-CAP.

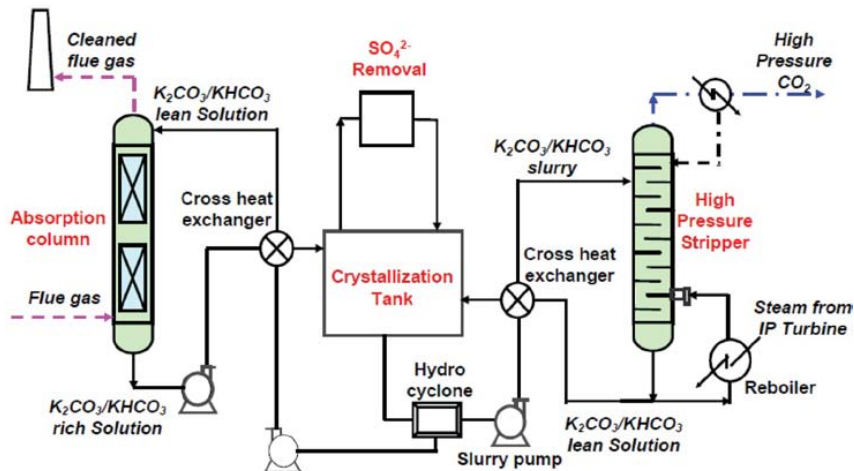

Figure 1: Hot Carbonate Absorption Process with High-Pressure Stripping Enabled by Crystallization (Hot-CAP)—Process Flow Diagram

TABLE 1: PROCESS PARAMETERS FOR CARBONATE SALT SOLVENT (based on 40 wt% [K₂CO₃ equivalent] K₂CO₃/KHCO₃ solution)

	Units	Current R&D Value	Target R&D Value
Pure Solvent			
Molecular Weight	mol ⁻¹	138 g/mol	N/A
Normal Boiling Point	°C	105–115 (depending on % K ₂ CO ₃ to KHCO ₃ conversion, i.e., CO ₂ loading)	N/A
Normal Freezing Point	°C	<0 (estimated)	N/A
Vapor Pressure at 15 °C	bar	N/A (not volatile)	N/A
Manufacturing Cost for Solvent	\$/kg	0.4–1.0 (dry, pure K ₂ CO ₃)	0.8
Working Solution			
Concentration	kg/kg	0.4	0.4
Specific Gravity (15 °C/15 °C)	—	1.42	N/A
Specific Heat Capacity at STP	kJ/kg-K	2.72	N/A
Viscosity at STP	cP	5.1	N/A
Absorption (Rich Solution at Bottom)			
Pressure (CO ₂ partial)	bar	0.09 (1.32 psia)	<0.1
Temperature	°C	60–80	60–80
Equilibrium CO ₂ Loading	mol/mol	0.4–0.45	0.4–0.45
Heat of Absorption	kJ/kg CO ₂	609	609
Solution Viscosity	cP	1.5	N/A

TABLE 1: PROCESS PARAMETERS FOR CARBONATE SALT SOLVENT
(based on 40wt% [K_2CO_3 equivalent] $K_2CO_3/KHCO_3$ solution)

	Units	Current R&D Value	Target R&D Value
Desorption (Lean Solution at Bottom)			
Pressure (CO_2 partial)	bar	0.3-1.7 (4-12 total pressure)	>0.6 (>6 total pressure and $CO_2/H_2O > 3:1$)
Temperature	$^{\circ}C$	140–200	<200
Equilibrium CO_2 Loading	mol/mol	0.20-0.40 (60 wt% slurry concentration)	0.20-0.40
Heat of Desorption	kJ/kg CO_2	600–1,500 (including heat of crystallization)	<1,500
Proposed Module Design		<i>(for equipment developers)</i>	
Flue Gas Flowrate	kg/hr	1,600,000	
CO_2 Recovery, Purity, and Pressure	%/%/bar	90%, 99%, 10 bar	
Absorber Pressure Drop	bar	0.07 (structured packing)	

Definitions:

STP – Standard Temperature and Pressure (15 $^{\circ}C$, 1 atm).

Pure Solvent – Chemical agent(s), working alone or as a component of a working solution, responsible for enhanced CO_2 absorption (e.g., the amine MEA in an aqueous solution).

Manufacturing Cost for Solvent – “Current” is market price of chemical, if applicable; “Target” is estimated manufacturing cost for new solvents, or the estimated cost of bulk manufacturing for existing solvents.

Working Solution – The solute-free (i.e., CO_2 -free) liquid solution used as the working solvent in the absorption/desorption process (e.g., the liquid mixture of MEA and water).

Absorption – The conditions of interest for absorption are those that prevail at maximum solvent loading, which typically occurs at the bottom of the absorption column. These may be assumed to be 1 atm total flue gas pressure (corresponding to a CO_2 partial pressure of 0.13 bar) and 40 $^{\circ}C$; however, measured data at other conditions are preferable to estimated data.

Desorption – The conditions of interest for desorption are those that prevail at minimum solvent loading, which typically occurs at the bottom of the desorption column. Operating pressure and temperature for the desorber/stripper are process-dependent (e.g., an MEA-based absorption system has a typical CO_2 partial pressure of 1.8 bar and a reboiler temperature of 120 $^{\circ}C$). Measured data at other conditions are preferable to estimated data.

Pressure – The pressure of CO_2 in equilibrium with the solution. If the vapor phase is pure CO_2 , this is the total pressure; if it is a mixture of gases, this is the partial pressure of CO_2 . Note that for a typical pulverized coal (PC) power plant, the total pressure of the flue gas is about 1 atm and the concentration of CO_2 is about 13.2 percent. Therefore, the partial pressure of CO_2 is roughly 0.132 atm or 0.130 bar.

Concentration – Mass fraction of pure solvent in working solution.

Loading – The basis for CO_2 loadings is moles of pure solvent.

Other Parameter Descriptions:

Chemical/Physical Solvent Mechanism –

The overall reaction for CO₂ absorption into potassium carbonate solution at 70–80 °C is:

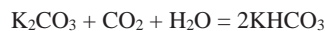

The CO₂-rich solution from the absorber is cooled to 30–35 °C to crystallize KHCO₃:

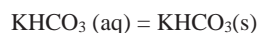

The overall reaction for CO₂ stripping using KHCO₃ slurry at 140–200 °C is:



Solvent Contaminant Resistance – K₂CO₃ reacts with the flue gas contaminants (e.g., SO₂, nitrogen oxide [NO_x], and hydrogen chloride [HCl]), to form K₂SO₄, KNO₃, and KCl, respectively, resulting in solvent losses if the salts are not reclaimed.

Solvent Foaming Tendency – K₂CO₃/KHCO₃ solution itself does not have a foaming problem. If an organic promoter is used, foaming may occur for the K₂CO₃/KHCO₃ + promoter solution. However, the foaming tendency is expected to be less severe than the conventional amine-based processes because the promoter concentration is generally low.

Flue Gas Pretreatment Requirements – If an organic promoter is used, pretreatment of the flue gas is required to reduce the concentration of SO₂ to below 30 parts per million by volume (ppmv). If an inorganic promoter or a catalyst is used, flue gas pretreatment can be eliminated by a K₂SO₄ reclamation process under development in this project.

Solvent Makeup Requirements – Stoichiometric loss of K₂CO₃ due to reactions with acidic gases in the flue gas (SO₂, NO_x, etc.) is estimated 1.46 kg K₂CO₃/tonne CO₂ captured based on the assumed 42 ppmv SO₂ and 74 ppmv NO_x in the flue gas exiting a wet flue gas desulfurization (FGD) unit.

If an organic promoter is used, the promoter has tendency to degrade. Since the promoter concentration is low and most of the promoter does not enter the Hot-CAP stripping column, nominal losses due to promoter degradation is estimated to be less than 10 percent of that in the conventional MEA-based processes.

Waste Streams Generated – Waste streams include sludge of inorganic salts (e.g., sulfate, nitrate, chloride, etc.) as a result of K₂CO₃/KHCO₃ reactions with acid gases in the flue gas and liquid blowdown from the process to avoid accumulation of chlorine, metals, etc.

Process Design Concept – Shown in Figure 2 below.

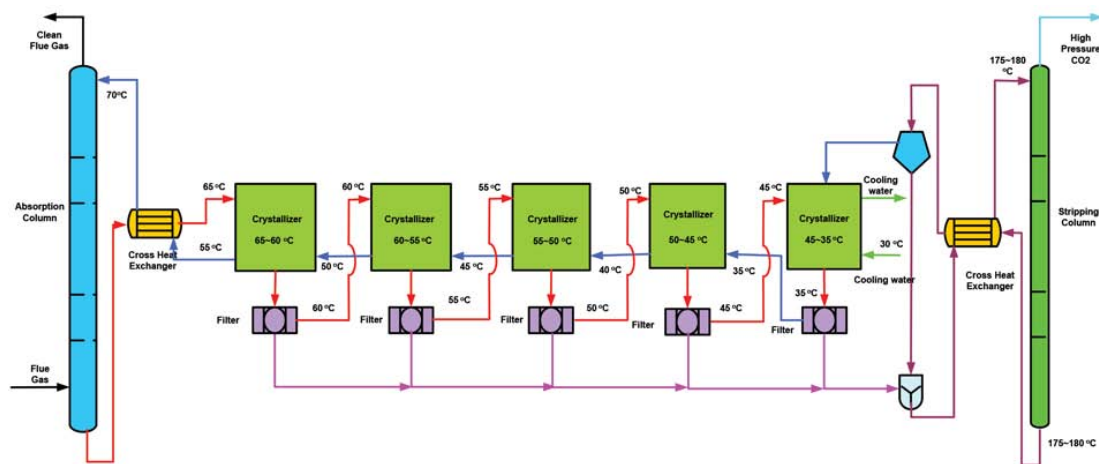

Figure 2: Process Design Concept

technology advantages

- High stripping pressure, which equates to low compression work and low stripping heat (high CO₂/H₂O ratio).
- Low sensible heat as a result of higher working capacity and lower Cp (1/2) compared with MEA.
- Low heat of absorption: 7–17 kcal/mol CO₂ (crystallization heat included) versus 21 kcal/mol for MEA.
- Increased absorption rate by employing high K₂CO₃ concentration and high absorption temperature.
- FGD may be eliminated.
- No degradation of the carbonate solution and low degradation of the promoter.
- Low-cost solvent.
- Less corrosiveness.

R&D challenges

- Identifying favorable process conditions and promoters/catalysts for achieving fast absorption kinetics in carbonate solution.
- Identifying process conditions and solution properties for achieving a fast crystallization rate and a desirable crystal size for solid separation.
- Identifying process conditions for potassium bicarbonate slurry to achieve stripping pressure ≥6 bar.
- Identifying process conditions for >95 percent SO₂ removal and continuous reclamation of the sulfate.
- Identifying risk mitigation strategies to prevent fouling on surfaces of heat exchangers and crystallizers due to bicarbonate crystallization.

results to date/accomplishments

- Three inorganic catalysts and five amine and three amino acid salt promoters were evaluated using a batch-stirred tank reactor.
- A bench-scale, packed-bed column was designed and fabricated to investigate the kinetics, mass transfer, and hydrodynamic performance of CO₂ absorption. Absorption column tests revealed that CO₂ removal efficiency by 40 wt% K₂CO₃/KHCO₃ solution promoted by either of two selected promoters at 70 °C was higher than that of the counterpart 5M MEA solution at 50 °C at the CO₂ loading levels typical of the two processes.
- Absorption column tests also showed that KHCO₃ precipitation could occur when the CO₂ loading reached a level equivalent to 40–45 percent of K₂CO₃ conversion. However, the accumulation of precipitates in the solution did not result in a pronounced decrease in CO₂ removal efficiency.
- Mixed suspension-mixed product removal (MSMPR) crystallization tests revealed that pure KHCO₃ crystals could be obtained and the crystallization of KHCO₃ was kinetically fast and a residence time of as few as 15 minutes was sufficient to obtain large crystal particles (>80 μm) required for efficient solid-liquid separation.
- Vapor Liquid Equilibrium (VLE) measurements for concentrated KHCO₃/K₂CO₃ aqueous systems with high levels of K₂CO₃ conversion at temperatures of 140–200 °C revealed the thermodynamic feasibility of high-pressure stripping (achieving both a high total pressure and a low H₂O/CO₂ pressure ratio).
- Parametric tests of reclaiming the potassium sulfate desulfurization byproduct were performed and results provided guidance for developing a modified process concept for the combined SO₂ removal and CO₂ capture. The feasibility of the modified process was preliminarily demonstrated. A bench-scale, packed-bed stripping column with a temperature rating of 200 °C and pressure rating of 500 pounds per square inch absolute (psia) was fabricated and installed at the UIUC laboratory.
- Parametric testing of high-pressure CO₂ stripping with concentrated bicarbonate-dominant slurries at high temperatures (≥140 °C) in the bench-scale stripping column demonstrated lower heat use than with MEA. For example, it was observed that compared with the 5 M MEA solution at 120 °C, the heat duty for CO₂ stripping at 160 °C from the 30 to 50 wt% KHCO₃/K₂CO₃ feed solutions with the CO₂ loading equivalent to 80 percent of carbonate conversion was two-to-three times lower.

- In addition to the experimental studies, the technical challenges pertinent to fouling of slurry-handling equipment and the design of the crystallizer and stripper were addressed through consultation with vendors and engineering analyses.
- A techno-economic analysis for the baseline Hot-CAP integrated with a 550-MWe power plant showed that the net power produced in the PC + Hot-CAP is 609 MWe, greater than the PC + MEA (550 MWe). The LCOE (levelized cost of electricity) increase for the Hot-CAP, including CO₂ transportation and storage, incurs a 60 percent increase over the base PC plant without CO₂ capture. The LCOE increase caused by the Hot-CAP is 29 percent lower than that for MEA.

next steps

This project ended on March 31, 2014.

available reports/technical papers/presentations

Shihan Zhang, Xinhui Ye, Yongqi Lu. Development of a Potassium Carbonate-based Absorption Process with Crystallization-enabled High-pressure Stripping for CO₂ Capture: Vapor-liquid Equilibrium Behavior and CO₂ Stripping Performance of Carbonate/Bicarbonate Aqueous Systems. *Energy Procedia* 2014, 63: 665-675.

Final Report, "Bench-Scale Development of a Hot Carbonate Absorption Process with Crystallization-Enabled High-Pressure Stripping for Post-Combustion CO₂ Capture," April 2014.

Final Project Review Presentation, May 2014.

Lu, Y., O'Brien K.; and Chen, S., "Bench-Scale Development of a Hot Carbonate Absorption Process with Crystallization-Enabled High Pressure Stripping for Post-Combustion CO₂ Capture," presented at the Project Review Meeting, Pittsburgh, PA, February 15, 2013. <http://www.netl.doe.gov/File%20Library/Research/Coal/ewr/co2/HotCAP-review-meeting-021513.pdf>.

Lu, Y., "Bench-Scale Development of a Hot Carbonate Absorption Process with Crystallization-Enabled High Pressure Stripping for Post-Combustion CO₂ Capture," 2012 NETL CO₂ Capture Technology Meeting, Pittsburgh, PA, July 2012. <http://www.netl.doe.gov/publications/proceedings/12/co2capture/presentations/2-Tuesday/Y%20Lu-ISGS-Hot%20CAP.pdf>.

Lu, Y., "Bench-Scale Development of a Hot Carbonate Absorption Process with Crystallization-Enabled High Pressure Stripping for Post-Combustion CO₂ Capture," 2011 NETL CO₂ Capture Technology Meeting, Pittsburgh, PA, August 2011.

DEVELOPMENT OF CHEMICAL ADDITIVES FOR CO₂ CAPTURE COST REDUCTION

primary project goals

Lawrence Berkeley National Laboratory (LBNL) is investigating a novel mixed solvent system that integrates amine-based, potassium-based, and ammonia-based solvents to provide benefits of three systems while avoiding many of their drawbacks.

technical goals

- Develop chemical additives for solvent systems to reduce the cost of post-combustion capture of carbon dioxide (CO₂).
- Determine the optimal process configuration and operating condition for the transfer of CO₂ in amine solvent to potassium carbonate (K₂CO₃), and then to an ammonium species, resulting in the production of NH₄HCO₃.

technical content

The new solvent system uses a novel solvent transfer approach after the capture of CO₂ from flue gas. Using this approach, the energy demand and the capital cost of solvent regeneration are expected to be significantly reduced compared to the monoethanolamine (MEA) system.

An aqueous solution of amine is used as an absorbent to facilitate favorable CO₂ absorption kinetics. The amine is chosen such that the CO₂ absorbed in an absorber can be readily transferred to potassium carbonate (K₂CO₃) in a recirculation tank to produce KHCO₃ solids. Subsequently, KHCO₃ solids enter into a regenerator by gravitation, where it reacts with an ammonia catalyst to regenerate K₂CO₃ for reuse and generate a concentrated CO₂ stream suitable for sequestration.

The approach contains the benefits of three solvent systems: amine, K₂CO₃ and ammonia systems. The benefits are: (1) amine's fast CO₂ absorption kinetics; (2) K₂CO₃ and ammonium species' low reagent cost, high chemical stability, and small heat capacity; and (3) ammonium bicarbonate's low decomposition temperature, fast decomposition kinetics, and amenable for high-pressure CO₂ production. The employment of solids significantly reduces the sensible and latent heat consumed by water in solvent regeneration. The low decomposition temperature of ammonium bicarbonate enables waste heat and/or low-quality steam to be used for the production of concentrated CO₂ gas.

technology maturity:

Bench-Scale, Simulated Flue Gas

project focus:

Chemical Additives for CO₂ Capture

participant:

Lawrence Berkeley National Laboratory

project number:

FWP-ED33EE

NETL project manager:

Elaine Everitt
elaine.everitt@netl.doe.gov

principal investigator:

Shih-Ger (Ted) Chang
LBNL
sgchang@lbl.gov

partners:

N/A

performance period:

6/1/08 – 5/31/13

TABLE 1: PROCESS PARAMETERS

	Units	Current R&D Value	Target R&D Value
Pure Solvent			
Molecular Weight	mol ⁻¹	100–212	100–212
Normal Boiling Point	°C	165–252	165–252
Normal Freezing Point	°C	(-50)–28	(-50)–28
Vapor Pressure at 15 °C	bar	0–0.0013	0–0.0013
Manufacturing Cost for Solvent	\$/kg	30–250	30–250
Working Solution			
Concentration	kg/kg	0.3–0.6	0.3–0.6
Specific Gravity (15 °C/15 °C)	-	0.9–1.7	0.9–1.7
Specific Heat Capacity at STP	kJ/kg-K	3–4	3–4
Viscosity at STP	cP	20–40	20–40
Absorption			
Pressure	bar	1.01	1–1.5
Temperature	°C	40–70	30–80
Equilibrium CO ₂ Loading	mol/mol	0.7–0.9	0.7–0.9
Heat of Absorption	kJ/mol CO ₂	65–75	65–75
Solution Viscosity	cP	10–15	10–15
Desorption			
Pressure	bar	2.7	1–75
Temperature	°C	80–120	80–300
Equilibrium CO ₂ Loading	mol/mol	0.4–0.6	0.4–0.6
Heat of Desorption	kJ/mol CO ₂	85–92	85–92
Proposed Module Design		<i>(for equipment developers)</i>	
Flue Gas Flowrate	kg/hr		
CO ₂ Recovery, Purity, and Pressure	%/%/bar	90%, 99%, 75 bar	
Absorber Pressure Drop	bar		

Definitions:

STP – Standard Temperature and Pressure (15 °C, 1 atm).

Pure Solvent – Chemical agent(s), working alone or as a component of a working solution, responsible for enhanced CO₂ absorption (e.g., the amine MEA in an aqueous solution).

Manufacturing Cost for Solvent – “Current” is market price of chemical, if applicable; “Target” is estimated manufacturing cost for new solvents, or the estimated cost of bulk manufacturing for existing solvents.

Working Solution – The solute-free (i.e., CO₂-free) liquid solution used as the working solvent in the absorption/desorption process (e.g., the liquid mixture of MEA and water).

Absorption – The conditions of interest for absorption are those that prevail at maximum solvent loading, which typically occurs at the bottom of the absorption column. These may be assumed to be 1 atm total flue gas pressure (corresponding to a CO₂ partial pressure of 0.13 bar) and 40 °C; however, measured data at other conditions are preferable to estimated data.

Desorption – The conditions of interest for desorption are those that prevail at minimum solvent loading, which typically occurs at the bottom of the desorption column. Operating pressure and temperature for the desorber/stripper are process-dependent (e.g., an MEA-based absorption system has a typical CO₂ partial pressure of 1.8 bar and a reboiler temperature of 120 °C). Measured data at other conditions are preferable to estimated data.

Pressure – The pressure of CO₂ in equilibrium with the solution. If the vapor phase is pure CO₂, this is the total pressure; if it is a mixture of gases, this is the partial pressure of CO₂. Note that for a typical pulverized coal (PC) power plant, the total pressure of the flue gas is about 1 atm and the concentration of CO₂ is about 13.2 percent. Therefore, the partial pressure of CO₂ is roughly 0.132 atm or 0.130 bar.

Concentration – Mass fraction of pure solvent in working solution.

Loading – The basis for CO₂ loadings is moles of pure solvent.

Other Parameter Descriptions:

Chemical/Physical Solvent Mechanism –

Absorber: Amine + CO₂ ↔ Amine-CO₂

Recirculation tank: Amine-CO₂ + K₂CO₃ + H₂O ↔ Amine + 2 KHCO₃↓

Regenerator: 2 KHCO₃ + (NH₄)⁺ → K₂CO₃ + H₂O + CO₂↑ + (NH₄)⁺

Solvent Contaminant Resistance – Sulfur dioxide (SO₂) has little impact to the amine. The amine is regenerated by chemical rather than thermal methods. The amine employed should be much more resistant to oxygen (O₂) and nitrogen oxides (NO_x) than MEA. Nevertheless, the reaction kinetics and products of O₂ and NO_x with amine need to be investigated.

Solvent Foaming Tendency – Solvent foaming was not observed in laboratory experiments.

Flue Gas Pretreatment Requirements – Flue gas from coal-fired power plants equipped with conventional pollution control systems does not require additional pretreatment. Residual SO₂ after dissolution can be separated from the liquid stream as K₂SO₃/K₂SO₄ precipitates. The formation of heat-stable salts with amine should not be an issue, as amine is regenerated by chemical rather than thermal methods involving steam.

Solvent Makeup Requirements – Amine is confined in the low-temperature absorber and recirculation tank loop. As a result, the thermal degradation, chemical degradation (due to the reactions with flue gas trace constituents), and emission loss (due to the volatility) are expected to be insignificant compared to the benchmark MEA process. Absorber is not expected to exhibit a plugging problem resulting in operation breakdown and reagent loss as KHCO₃ solid is produced in the recirculation tank located above the K₂CO₃ regeneration tank (i.e., the stripper). A long-term integration test that lasts a significant number of hours will be needed to determine the amine's makeup requirements. KHCO₃ and K₂CO₃ are stable chemicals and do not degrade under high-temperature operation in the regenerator.

Waste Streams Generated – Waste streams from the absorber/recirculation tank low-temperature loop may contain trace amount of fly ash, dissolved NO_x, and amine degradation products. Waste streams from the stripper are expected to contain K₂SO₃ and K₂SO₄, if SO₂ polishing is not equipped ahead of the CO₂ capture system.

Process Design Concept – Shown in Figure 1 below.

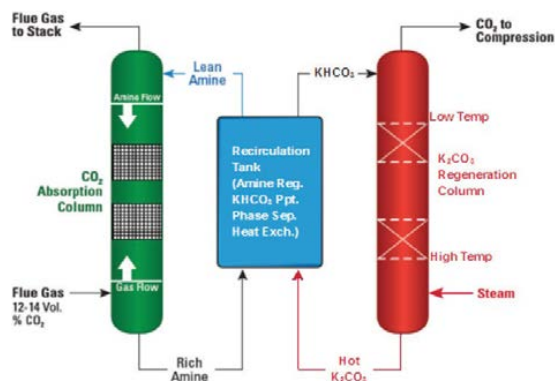

Figure 1: Process Design Concept

Proposed Module Design – Unless noted, flue gas feed pressure is 1.014 bar, temperature is 57 °C, and composition leaving the flue gas desulfurization (FGD) unit (wet basis) should be assumed:

Composition (% vol)					Composition (ppmv)	
CO ₂	H ₂ O	N ₂	O ₂	Ar	SO _x	NO _x
13.17	17.25	66.44	2.34	0.8	42	74

technology advantages

- Possession of high-CO₂ absorption kinetics, resulting in an acceptable absorber capital cost.
- Reduction of processing water, resulting in reduced solvent regeneration energy demands.
- Employment of low-heat capacity KHCO₃/K₂CO₃, resulting in reduced sensible heat demands.
- Reduction of reagent loss and equipment corrosion, resulting in reduced operation costs.
- Reduction of emission as KHCO₃ can be treated at high temperature without any emissions of heat degradable harmful products.
- Reduction of CO₂ compression ratio, resulting in reduced CO₂ compression energy and compressor capital costs.

R&D challenges

- Development of a new system for the transfer of KHCO₃ solid from the recirculation tank to the stripper by the gravitation method and with pressurized steam.
- Determination of the optimal operation condition to regenerate K₂CO₃ and to produce high pressure CO₂ gas for enhanced oil recovery (EOR) or methanol production.

results to date/accomplishments

- Evaluated more than 50 amines and amino acid salts for CO₂ absorption amenable for the new solvent regeneration approach.
- Compared relative CO₂ absorption efficiencies of various lean amines regenerated by chemical methods.

- Investigated conditions required for phase separation and determined phase diagrams following chemical regeneration of lean amine in the recirculation tank in attempt to understand its chemical and physical behaviors.
- Elucidated the kinetics and mechanisms of CO₂ absorption and chemical regeneration involved in the new solvent system.
- Constructed a stripper system equipped with a calorimeter for the determination of K₂CO₃ regeneration rates and energy demands. Preliminary results indicated that K₂CO₃ regeneration energy demand was 2,079 kJ/kg CO₂ at steady-state conditions, which is approximately 40 percent less than that of MEA.
- Performed a semi-continuous integration test encompassing CO₂ absorption in the absorber, amine regeneration in the recirculation tank, and K₂CO₃ regeneration and CO₂ production in the stripper.
- Performed mass and water balances, and developed a stream table of the bench-scale new solvent system.

next steps

Project completed May 31, 2013.

available reports/technical papers/presentations

“Developing Chemical Additives for Aqueous Ammonia to Reduce CO₂ Capture Cost,” presented at the Annual NETL CO₂ Capture Technology for Existing Plants Meeting, Pittsburgh, PA, March 2009.

“Development of Chemical Additives for CO₂ Capture Cost Reduction,” presented at the 2010 NETL CO₂ Capture Technology Meeting, Pittsburgh, PA, September 2010.

<http://www.netl.doe.gov/publications/proceedings/10/CO2capture/presentations/monday/Ted%20Chang-LBNL.pdf>.

“Development of Chemical Additives for CO₂ Capture Cost Reduction,” presented at the 2011 NETL CO₂ Capture Technology Meeting, Pittsburgh, PA, August 2011. <http://www.netl.doe.gov/publications/proceedings/11/CO2capture/presentations/2-Tuesday/23Aug11-Chang-LBNL-Additives%20for%20Reducing%20CO2%20Capture%20Costs.pdf>.

“Development of Chemical Additives for CO₂ Capture Cost Reduction,” presented at the 2012 NETL CO₂ Capture Technology Meeting, Pittsburgh, PA, August 2012. <http://www.netl.doe.gov/publications/proceedings/12/CO2capture/presentations/2-Tuesday/T%20Chang-LBNL-Additives.pdf>.

“Development of Chemical Additives for CO₂ Capture Cost Reduction,” presented at the 2013 NETL CO₂ Capture Technology Meeting, Pittsburgh, PA, July 2013. <http://www.netl.doe.gov/File%20Library/events/2013/CO2%20capture/Y-Li-LBNL-Additives-for-Reducing-CO2-Capture-Costs.pdf>.

POST-COMBUSTION CO₂ CAPTURE FOR EXISTING PC BOILERS BY SELF-CONCENTRATING AMINE ABSORBENT

primary project goals

3H Company set out to experimentally and analytically confirm the feasibility of the proposed Self-Concentrating Absorbent CO₂ Capture Process, with the goal of developing a sound engineering design, supported by laboratory data and economic justification, for a flue gas slipstream-testing unit.

technical goals

- Perform laboratory screening experiments to identify different absorbent/solvent combinations that can exhibit the “self-concentrating” carbon dioxide (CO₂) absorption effect, and conduct fundamental absorption/regeneration rates and physical and chemical property measurements to allow its process design and techno-economic feasibility to be evaluated.
- Conduct experiments to demonstrate the process under dynamic column testing conditions and to develop a process design package for a slipstream testing facility.

technical content

This project examined an innovative and proprietary CO₂ capture technology developed by 3H Company. The process is based on amine and/or other chemical absorbents in a non-aqueous solvent that can phase separate into a distinct CO₂-rich liquid phase upon reaction with CO₂. The process was demonstrated using commercially available amines and solvents. The technology has the potential of not only greatly reducing the energy penalty associated with regeneration compared to conventional monoethanolamine (MEA)-based processes, but it can also increase the amine CO₂ absorption rate. Preliminary experimental data shows that the proposed Self-Concentrating Amine Absorbent process has the potential of reducing the total regeneration energy by as much as 70 percent.

The technology removes CO₂ from power plant flue gas, using an absorbent (e.g., amine or special designed chemical species) and a matched solvent, which rapidly forms two immiscible liquid phases upon absorbing CO₂ (Figure 1). The process has been demonstrated in the laboratory for a number of specific amine/solvent pairs. The solvents employed are non-aqueous. The novelty of the concept rests on the dual hydrophobic/hydrophilic functionality of the CO₂ absorbents (e.g., amine), the stability of the “CO₂-rich” reaction product, and its solubility behavior within the non-aqueous solvent system employed. When an amine is used as the CO₂ absorbent, it is reasonable to assume that the chemistry follows that for an aqueous-based system. However, in the presence of a Self-Concentrating Solvent, the CO₂:amine reaction forms a stable product that can be solvated in higher concentration within the solvent system. The chemistry and mechanism of the process requires additional research and development (R&D).

technology maturity:

**Laboratory-Scale,
Simulated Flue Gas**

project focus:

CO₂ Capture with Self-Concentrating Amine Absorbent

participant:

3H Company

project number:

FE0004274

NETL project manager:

Morgan Mosser
morgan.mosser@netl.doe.gov

principal investigator:

Liang Hu
3H Company
lianghu59@yahoo.com

partners:

Nexant, Inc.
LG&E and KU Energy LLC
EPRI

performance period:

10/1/10 – 1/31/13

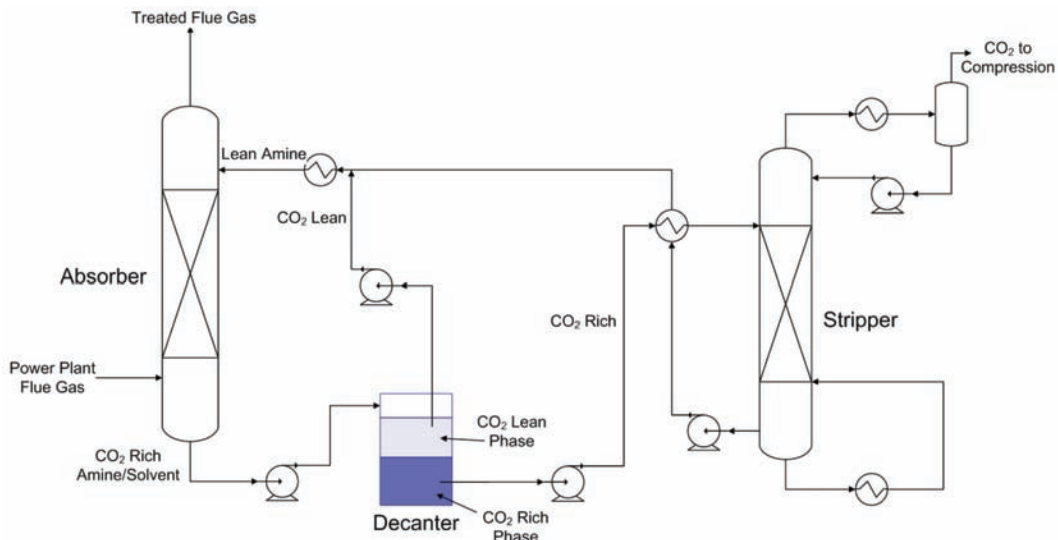

Figure 1: Concept of the Proposed Self-Concentrating Amine Absorbent Process

Conventional 30 wt% MEA-based CO₂ capture is considered to be the benchmark for performance. A typical heat of regeneration for a 30 percent MEA CO₂ capture process is about 1,934 Btu/lb CO₂, as cited in the literature, and only about 1/3 of the regeneration energy is used to break the amine:CO₂ bonds. Minimizing the overall heat of regeneration by using a unique absorbent/solvent system is the key to the Self-Concentrating Absorbent process. Figure 2 shows a flow scheme for the concept, using amine as the CO₂ absorbent. The flow scheme is similar to a conventional MEA process, with the exception that a decanter is incorporated downstream of the absorber to allow the “rich CO₂ liquid” to be fully phase separated before sending it onto the stripper. Only the “rich CO₂ liquid” is subjected to regeneration, at a significant reduced volume as compared to a conventional MEA process. Overall, a 70 percent reduction in heat of regeneration can be achieved with the Self-Concentrating Absorbent process, taking into consideration that (1) only the “rich CO₂/solvent liquid” will be sent onto regeneration with minimum excess solvent, and (2) the solvent has a lower heat capacity and heat of vaporization than water. Because the process uses a non-aqueous system, many of the problems associated with MEA, including degradation due to corrosion, oxygen degradation, and the formation of stable salts, are expected to be mitigated. These types of effects, along with the potential environmental emissions and health problems associated with the use of the non-aqueous process, will need to be investigated in more detail.

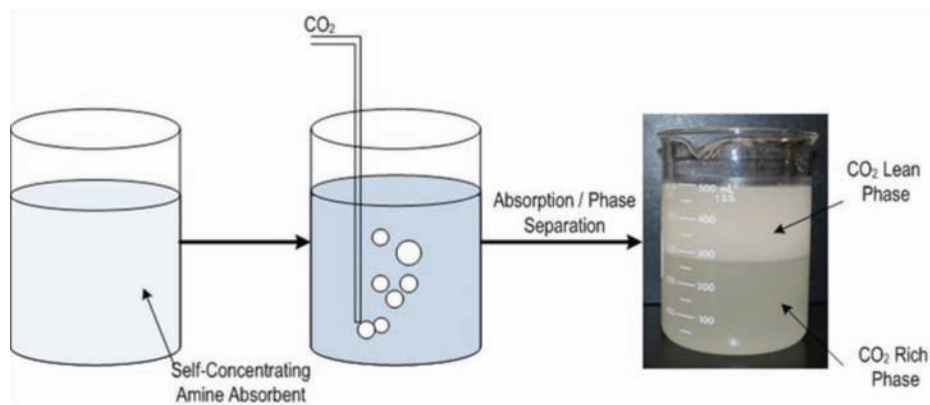

Figure 2: Simplified Flow Scheme of the Proposal Self-Concentrating Amine Absorbent Concept

technology advantages

- Lower regeneration energy requirements.
- Minimal degradation due to corrosion, oxygen degradation, and the formation of stable salts.

R&D challenges

- The chemistry, kinetics, and mass-transfer characteristics governing the diffusion of CO₂ into the liquid phase where it reacts with amine within the non-aqueous solvent, etc., are unknown.
- The self-concentrating process involves the phase separation of the “CO₂ rich” reaction product from the solvent system, of which its stability, composition, phase behavior, thermodynamic miscibility, and solubility limit are unknown.
- It is necessary to develop some basic theoretical and mechanistic understanding of the process so that R&D will not have to be based purely on an empirical approach.

results to date/accomplishments

- Completed preliminary system analysis and process design study comparing the 3H process to 30 percent MEA.
- Completed bench-scale screening, property measurement, and testing to identify all four promising Self-Concentrating Absorbent/Solvent pairs for more detailed characterization and evaluation.
- Completed down-selection to two promising Self-Concentrating Absorbent/Solvent pairs and commenced detailed characterization and analysis of these two final absorbent/solvent pairs.

next steps

This project ended on January 31, 2013.

available reports/technical papers/presentations

Hu, L., “Post-Combustion CO₂ Capture for Existing PC Boilers by Self-Concentrating Absorbent,” presented at the 2012 NETL CO₂ Capture Technology Meeting, Pittsburgh, Pennsylvania, July 2012. <http://www.netl.doe.gov/publications/proceedings/12/co-2capture/presentations/2-Tuesday/L%20Hu-%203H%20Company-Self-concentrating%20Absorbent.pdf>.

IONIC LIQUIDS: BREAKTHROUGH ABSORPTION TECHNOLOGY FOR POST-COMBUSTION CO₂ CAPTURE

primary project goals

The University of Notre Dame set out to develop a new ionic liquid (IL) solvent capture process resulting in a small increase in cost of electricity (COE) compared to currently available capture technologies by overcoming viscosity and capacity issues impacting cost and performance of ILs via “proof-of-concept” exploration and laboratory-/bench-scale testing of a variety of IL formulations.

technical goals

- Design and synthesize one or more IL absorbents tailored for post-combustion carbon dioxide (CO₂) capture.
- Perform atomistic-level classical and quantum calculations to engineer IL structures maximizing CO₂ carrying capacity with minimal regeneration costs.
- Measure or accurately estimate all physical solvent properties essential for detailed engineering and design calculations:
 - Gas solubility, viscosity, heat of absorption, heat capacity, mass transfer coefficients, thermal decomposition, chemical stability, and corrosivity.
- Complete detailed systems and economic analysis.
- Demonstrate CO₂ capture technology on a continuous lab-scale unit.

technical content

ILs are salts that are liquid at room temperature. They are known to have high intrinsic physical solubility for CO₂. Examples of ILs are illustrated in Figure 1.

technology maturity:

**Laboratory-Scale,
Simulated Flue Gas**

project focus:

Ionic Liquids

participant:

University of Notre Dame

project number:

FC26-07NT43091

NETL project manager:

David Lang
david.lang@netl.doe.gov

principal investigator:

Edward J. Maginn
University of Notre Dame
ed@nd.edu

partners:

Babcock and Wilcox
DTE
Trimeric Corporation
Koei Chemical

performance period:

2/28/07 – 9/30/12

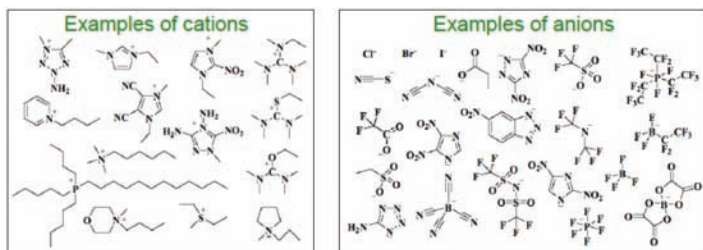

Figure 1: Examples of Ionic Liquids

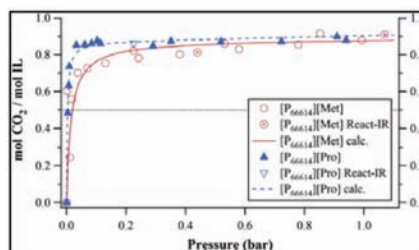

Figure 2: Isotherms confirming 1:1 binding

A close-to-conventional absorber/stripper process is assumed for process modeling and costing. Process simulation has been used to evaluate the sensitivity of a representative 500-MW (gross capacity), coal-fired power plant CO₂ capture process for the properties of ILs. The results were used to guide the development of the next generation of ILs. Salient project details include:

- Anion/cation functionalization: Notre Dame has developed both 1:1 and 2:1 (IL:CO₂) stoichiometries by adding chemical functionality to the anion and cation, respectively. Molecular modeling calculations were used to identify anion-functionalized ILs with minimal increase in solvent viscosity after CO₂ absorption. Two ILs (NDIL0046 and NDIL0157) were identified. NDIL0046 was used for lab-scale experimental tests, and data on NDIL0157 was used for techno-economic analysis.
- Enthalpy of reaction: Process modeling indicated that the binding strength of NDIL0046 needed to be improved, and a new IL (NDIL0157) with optimal enthalpy of reaction and lower heat capacity was identified. Optimal reaction enthalpy leads to higher CO₂ solvent capacities, reduced solvent circulation rate, and lowered sensible heating load.

Results show much lower parasitic energy compared with a monoethanolamine (MEA) system. From techno-economic analysis, it was estimated that the parasitic electricity losses in the reboiler are reduced by 36 percent, compression load increased by 14 percent, and the auxiliary losses in CO₂ capture are lowered by 34 percent. The best-case IL (NDIL0157) has almost the same increase in levelized cost of electricity (LCOE) compared with MEA due to higher capital costs for the CO₂ capture system.

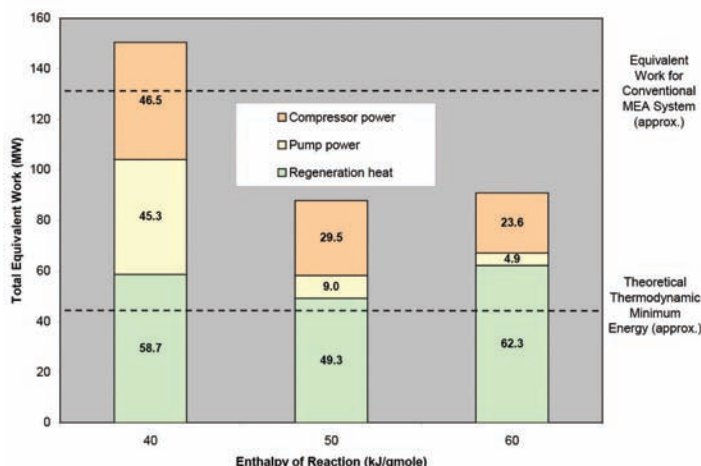

Figure 3: Results from Sensitivity Studies on the Parasitic Power Requirement of Ionic Liquid Solvents

TABLE 1: PROCESS PARAMETERS FOR IONIC LIQUID SOLVENTS

	Units	Current R&D Value	Target R&D Value
Pure Solvent			
Molecular Weight	mol ⁻¹	575	322
Normal Boiling Point	°C	N/A - does not boil	N/A - does not boil
Normal Freezing Point	°C	< -100C	< -100C
Vapor Pressure @ 15°C	bar	Essentially zero	Essentially zero
Manufacturing Cost for Solvent	\$/kg	\$20/kg	< \$15/kg
Working Solution			
Concentration	kg/kg	0.998	> 0.9
Specific Gravity (15°C/15°C)	-	0.907	≈1.0
Specific Heat Capacity @ STP	kJ/kg-K	2.25	<2.3
Viscosity @ STP	cP	158 @40 c	< 100
Absorption			
Pressure	bar	1.03	1
Temperature	°C	40-52	40-52
Equilibrium CO ₂ Loading	mol/mol	0.167	0.988
Heat of Absorption	kJ/mol CO ₂	43	54
Solution Viscosity	cP	129	< 100
Desorption			
Pressure	bar	1.3	1-3
Temperature	°C	120-188	120-204
Equilibrium CO ₂ Loading	mol/mol	0.041	0.51
Heat of Desorption	kJ/mol CO ₂	43	54
Proposed Module Design		<i>(for equipment developers)</i>	
Flue Gas Flowrate	kg/hr	N/A	
CO ₂ Recovery, Purity, and Pressure	% / % / bar	N/A	
Absorber Pressure Drop	bar	N/A	
Estimated Absorber/Stripper Cost of Manufacturing and Installation	$\frac{\$}{\text{kg/hr}}$	N/A	

Definitions:

STP – Standard Temperature and Pressure (15°C, 1 atm).

Pure Solvent – Chemical agent(s), working alone or as a component of a working solution, responsible for enhanced CO₂ absorption (e.g., the amine MEA in an aqueous solution).

Manufacturing Cost for Solvent – “Current” is market price of chemical, if applicable; “Target” is estimated manufacturing cost for new solvents, or the estimated cost of bulk manufacturing for existing solvents.

Working Solution – The solute-free (i.e., CO₂-free) liquid solution used as the working solvent in the absorption/desorption process (e.g., the liquid mixture of MEA and water).

Absorption – The conditions of interest for absorption are those that prevail at maximum solvent loading, which typically occurs at the bottom of the absorption column. These may be assumed to be 1 atm total flue-gas pressure (corresponding to a CO₂ partial pressure of 0.13 bar) and 40°C; however, measured data at other conditions are preferable to estimated data.

Desorption – The conditions of interest for desorption are those that prevail at minimum solvent loading, which typically occurs at the bottom of the desorption column. Operating pressure and temperature for the desorber/stripper are process-dependent (e.g., an MEA-based absorption system has a typical CO₂ partial pressure of 1.8 bar and a reboiler temperature of 120°C). Measured data at other conditions are preferable to estimated data.

Pressure – The pressure of CO₂ in equilibrium with the solution. If the vapor phase is pure CO₂, this is the total pressure; if it is a mixture of gases, this is the partial pressure of CO₂. Note that for a typical pulverized-coal power plant, the total pressure of the flue gas is about 1 atm and the concentration of CO₂ is about 13.2 percent. Therefore, the partial pressure of CO₂ is roughly 0.132 atm or 0.130 bar.

Concentration – Mass fraction of pure solvent in working solution.

Loading – The basis for CO₂ loadings is moles of pure solvent.

Estimated Cost – Basis is kg/hr of CO₂ in CO₂-rich product gas; assuming targets are met.

Other Parameter Descriptions:

Chemical/Physical Solvent Mechanism – A 1:1 reaction with CO₂ and the basic group on the anion of the IL.

Solvent Contaminant Resistance – Resistant to air; have not evaluated resistance to other contaminants.

Solvent Foaming Tendency – Low.

Flue Gas Pretreatment Requirements – Flue gas desulfurization (FGD) plus polishing column to get to 10 parts per million (ppm) sulfur oxide (SO_x).

Solvent Make-Up Requirements – 3.15 tons/day for a 550-MW net plant.

Waste Streams Generated – Degraded solvent waste; negligible vapor emissions.

Process Design Concept – Flowsheet/block flow diagram, if not included above.

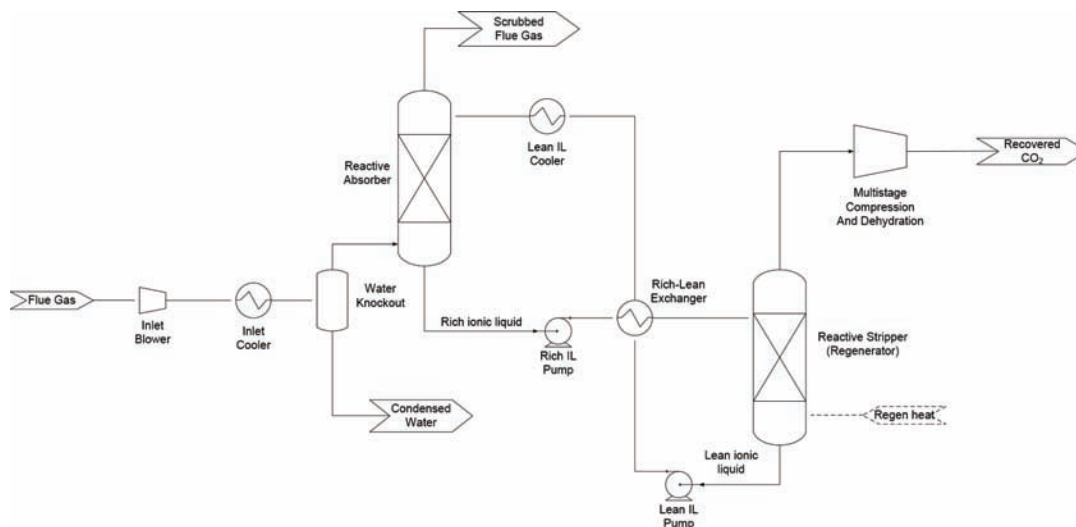

Figure 4: Schematic of Process Design Concept

Proposed Module Design – Unless noted, flue gas feed pressure is 1.014 bara, temperature is 57°C, and composition leaving the flue gas desulfurization (FGD) unit (wet basis) should be assumed:

Composition (% vol)					Composition (ppmv)	
CO ₂	H ₂ O	N ₂	O ₂	Ar	SO _x	NO _x
13.17	17.25	66.44	2.34	0.8	42	74

technology advantages

- Low volatility and good thermal stability.
- Wide liquidus range.
- Net-CO₂ uptake by solvent can be varied by tuning the enthalpy of CO₂ absorption (10 to 80 kJ/mol) through a combination of computational methods and experimental synthesis.
- Anhydrous absorption process.
- The viscosity of the current generation of ILs (NDIL0046) does not change significantly with CO₂ absorption.

R&D challenges

- The solvent CO₂ capacity (on a weight basis) should be higher than that for the best-case scenario (NDIL0157) to lower-solvent recirculation rates and reduce absorber costs.
- The effects of water on the corrosion behavior and CO₂ reactivity of the ILs need to be examined in greater detail, though preliminary results show negligible corrosion for NDIL0046 + carbon steel.
- The chemically functionalized IL solvent mass-transfer characteristics/viscosity need to be improved to lower capital and operating costs.
- Low-cost commercial synthesis routes for Generation III ILs are required to lower operating costs.

results to date/accomplishments

All project phases (I, II, and III) are complete. Key accomplishments to date include:

- Discovered and synthesized a new class of non-aqueous ILs reacting with 1:1 stoichiometry, and with no increase in viscosity following CO₂ absorption.
- Developed molecular modeling techniques that enabled the computation of key properties of ILs from first principles, and tuned the binding strength of ILs to optimize process economics.
- Demonstrated that the NDIL0046 IL had significantly lower corrosion rates compared to aqueous MEA, indicating that lower-cost materials could be used for absorber and heat exchangers.
- Techno-economic analysis on the best IL to date (NDIL0157) suggests favorable COE and significantly lower parasitic energy losses compared to aqueous MEA (U.S. Department of Energy [DOE]/National Energy Technology Laboratory [NETL] Baseline Case 12).
- Developed unique experimental techniques, including the ability to monitor the infrared spectrum of the IL as it absorbs CO₂, and then use this information to determine reaction rates and mechanisms.

next steps

The project ended on September 30, 2012. Recommendations for further steps include:

- Scale-up of experiments to the next level using synthetic flue gas and slipstream tests.
- The operating performance of ILs (mass-transfer characteristics, viscosity) would be improved.
- Process chemistry improvements needed to make ILs at tonne-scales for lower cost would be investigated.
- IL toxicity and long-term stability would also be examined.

available reports/technical papers/presentations

M. McCready et al., “Ionic Liquids: Breakthrough Absorption Technology for Post-Combustion CO₂ Capture,” presented at the 2012 NETL CO₂ Capture Technology Meeting, Pittsburgh, Pennsylvania, July, 2012. Available at: <http://www.netl.doe.gov/publications/proceedings/12/co2capture/presentations/2-Tuesday/M%20McCready-Notre%20Dame-Ionic%20Liquids.pdf>.

W. F. Schneider and E. Mindrup, “First-Principles Evaluation of CO₂ Complexation In Functionalized Ionic Liquids,” Symposium on Ionic Liquids: From Knowledge to Application, American Chemical Society National Meeting, Philadelphia, Pennsylvania, August 17-21, 2008.

K. E. Gutowski and E. J. Maginn, “Amine-Functionalized Task Specific Ionic Liquids for CO₂ Capture,” Symposium on Ionic Liquids: From Knowledge to Application, American Chemical Society National Meeting, Philadelphia, Pennsylvania, August 17-21, 2008.

Joan F. Brennecke, “CO₂ Capture – Challenges and Opportunities,” Energy, Citizens and Economic Transformation for Indiana and America, University of Notre Dame, July 7, 2008.

Joan F. Brennecke, Jessica L. Anderson, Alexandre Chapeaux, Devan E. Kestel, Zulema K. Lopez-Castillo, and Juan C. de la Fuente, “Carbon Dioxide Capture Using Ionic Liquids,” 236th ACS National Meeting, Philadelphia, Pennsylvania, August 17, 2008.

E. M. Mindrup and W. F. Schneider, “Comparison of Functionalized Amine Energetics for CO₂ Capture,” poster presented at the AIChE Annual Meeting, Philadelphia, Pennsylvania 2008.

Wei Shi and E. J. Maginn, “Molecular simulation of pure and mixture gases absorption in ionic liquids,” presented at the AIChE Annual Meeting, Philadelphia, Pennsylvania 2008.

Wei Shi and E. J. Maginn, “Molecular simulation and regulation solution theory modeling of pure and mixed gas absorption in the ionic liquid 1-n-butyl-3-methylimidazolium Bis(Trifluoromethylsulfanyl)amide ([hmim][Tf₂N]),” *Journal of Physical Chemistry B*, 112(51), 16710-16720.

Fisher, K.S., et al. Advanced Amine Solvent Formulations and Process Integration for Near-Term CO₂ Capture Success. Final Report to DOE/NETL. Grant No. DE-FG02-06ER84625, June 2007.

Christina Myers, Henry Pennline, David Luebke, Jeffery Ilconich, JaNeille Dixon, Edward J. Maginn, and Joan F. Brennecke, “High Temperature Separation of Carbon Dioxide/Hydrogen Mixtures Using Facilitated Supported Liquid Membranes,” *Journal of Membrane Science*, 2008, 322, 28-31.

Xiaochun Zhang, Feng Huo, Zhiping Liu, Wenchuan Wang, Edward Maginn and Wei Shi, “Absorption of CO₂ in the Ionic Liquid 1-n-hexyl-3-methylimidazolium tris(pentafluoroethyl)trifluorophosphate ([hmim][FEP]): A Molecular View by Computer Simulations,” *Journal of Physical Chemistry B*, 2009, 113, 7591-7598.

Keith Gutowski and Edward J. Maginn, “Amine-Functionalized Task-Specific Ionic Liquids: A Mechanistic Explanation for the Dramatic Increase in Viscosity Upon Complexation with CO₂ from Molecular Simulation,” *Journal of the American Chemical Society*, 2008, 130, 14690-14704.

E. J. Maginn, Developing New Ionic Liquids for CO₂ Capture: A Success Story for Thermodynamics and Computational Molecular Design, GE Global Research Symposium on Emissions and Aftertreatment, GE Global Research Center, Niskayuna, New York, Sept. 17, 2009.

Marcos Perez-Blanco and Edward J. Maginn, "Molecular Dynamics Simulations of CO₂ at an Ionic Liquid Interface: Adsorption, Ordering and Interfacial Crossing," *Journal of Physical Chemistry B* (cover article), 2010, 36, 11827.

W. F. Schneider, "Ionic Liquids for CO₂ Capture from First-Principles," CECAM workshop on Carbon Capture, Lausanne, Switzerland, July 26-28, 2010.

W. F. Schneider and E. Mindrup, "AHA! Computational design of aprotic heterocyclic anions for ionic-liquid-based CO₂ separations," Division of Fuel Chemistry, American Chemical Society National Meeting, Boston, Massachusetts, August 22-26, 2010.

Burcu E. Gurkan, Juan C. de la Fuente, Elaine M. Mindrup, Lindsay E. Ficke, Brett F. Goodrich, Erica A. Price, William F. Schneider, and Joan F. Brennecke, "Equimolar CO₂ absorption by anion-functionalized ionic liquids," *J. Am. Chem. Soc.*, 132, 2010, 2116-2117.

Burcu E. Gurkan, Juan de la Fuente, Elaine M. Mindrup, Lindsay E. Ficke, Brett F. Goodrich, Erica A. Price, William F. Schneider, Edward J. Maginn and Joan F. Brennecke, "Chemically Complexing Ionic Liquids for Post-Combustion CO₂ Capture," Clearwater Clean Coal Conference, Clearwater, FL, June 6-10, 2010.

Edward J. Maginn, "Molecular engineering of new ionic liquid sorbents for CO₂ capture" at the 9th Annual Carbon Capture and Sequestration Meeting, Pittsburgh, Pennsylvania, May 2010.

Edward J. Maginn, Joan F. Brennecke, William F. Schneider, and Mark J. McCreedy, "Ionic Liquids: Breakthrough Absorption Technology for Post-combustion CO₂ Capture," presented at the NETL CO₂ Capture Technology Meeting, Pittsburgh, Pennsylvania, September, 2010.

DEVELOPMENT AND EVALUATION OF A NOVEL INTEGRATED VACUUM CARBONATE ABSORPTION PROCESS

primary project goals

The Illinois State Geological Survey (ISGS) set out to prove the novel Integrated Vacuum Carbonate Absorption Process (IVCAP) concept and further improve the energy efficiency of the process for post-combustion carbon dioxide (CO₂) capture.

technical goals

- Test the proof-of-concept of the IVCAP.
- Identify an effective catalyst for accelerating CO₂ absorption.
- Identify an effective additive for reducing the stripping heat.
- Evaluate a modified IVCAP as a multi-pollutant control process for combined sulfur dioxide (SO₂) and CO₂ capture.

technical content

The proposed IVCAP employs a potassium carbonate (K₂CO₃) aqueous solution for CO₂ absorption. While the absorption takes place at atmospheric pressure, the stripper is operated under a vacuum condition. As seen in Figure 1 and Table 1, the low heat of reaction between CO₂ and K₂CO₃ favors a stripping process operated at a low temperature and the low-quality steam (close to the exhaust end of low-pressure turbine in the power plant) can be used as a heat source for the stripping process as a result.

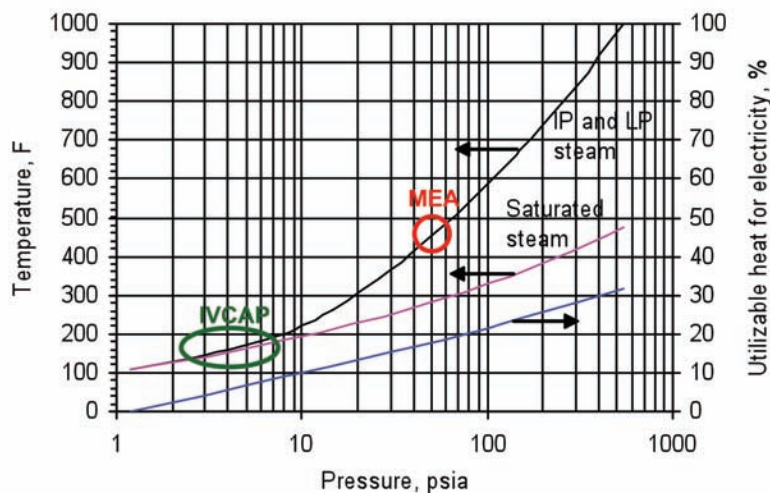

Figure 1: Steam Properties During Expansion in the Intermediate- and Low-Pressure Turbines

technology maturity:

**Laboratory-Scale,
Simulated Flue Gas**

project focus:

**Novel Integrated Vacuum
Carbonate Process**

participant:

**Illinois State Geological
Survey**

project number:

NT0005498

NETL project manager:

Andrew Jones
andrew.jones@netl.doe.gov

principal investigator:

Yongqi Lu
**Illinois State Geological
Survey**
yongqilu@illinois.edu

partners:

Calgon Carbon Corporation
Illinois Clean Coal Institute
University of Illinois

performance period:

10/1/08 – 4/30/12

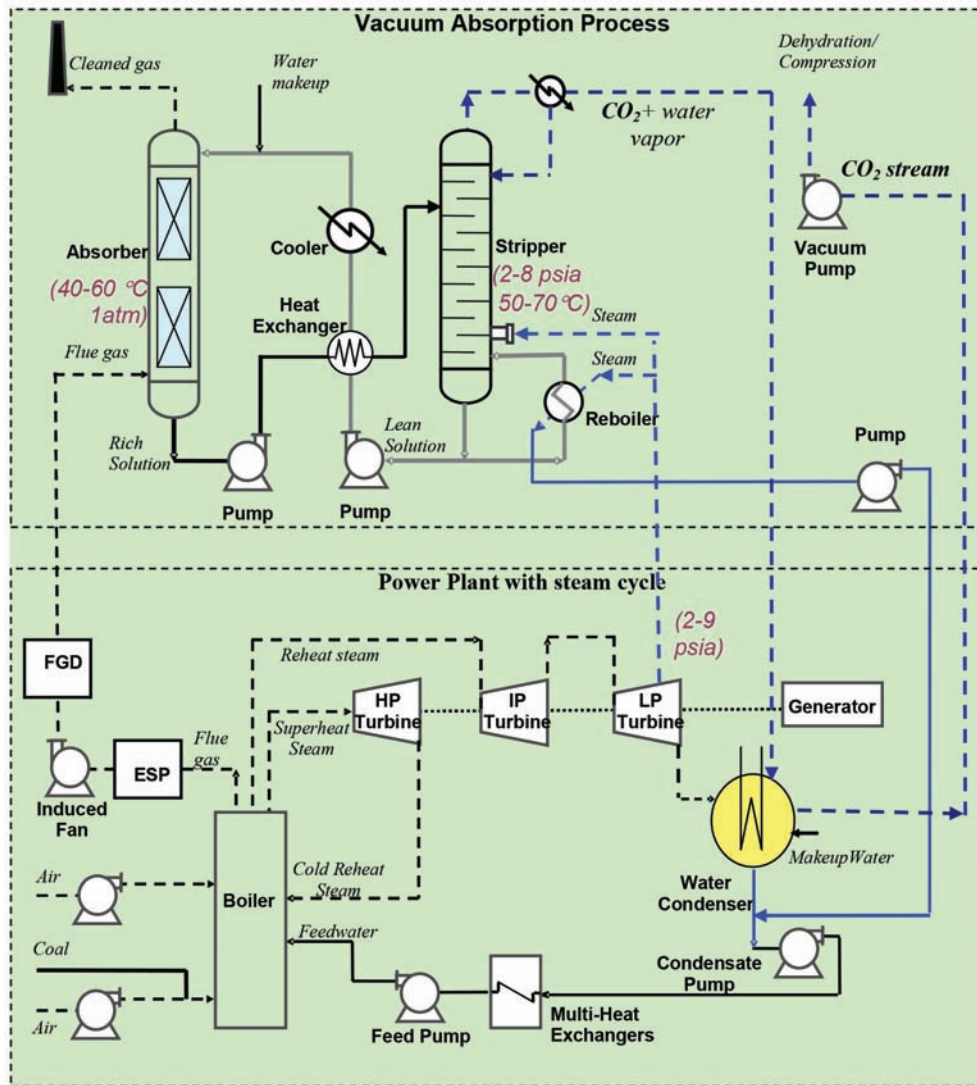

Figure 2: Vacuum Stripping in the IVCAP Allows for Use of Low-Quality Steam From the Power Plant

TABLE 1: A COMPARISON OF HEATS OF ABSORPTION FOR CO₂ SOLVENTS

Solvent	Main Reaction	Heat of Absorption
Primary/Secondary Amines	$2RR'NH + CO_2 = RR'NCOO^- + RR'NH_2^+$	MEA: 1,900 kJ/kg
Tertiary Amine	$RR'R''N + CO_2 + H_2O = HCO_3^- + RR'R''NH^+$	MDEA: 1,200 kJ/kg
Carbonate	$CO_3^{2-} + CO_2 + H_2O = 2 HCO_3^-$	600 kJ/kg

The intrinsic rate of CO₂ absorption into the K₂CO₃ solution is much slower than that in a monoethanolamine (MEA) solution; therefore, enzyme catalysts were developed to promote the absorption rate. Unlike the mixing of another solvent into a primary solvent, a catalyst accelerates the absorption rate without increasing the heat of absorption of the solvent.

The enzyme catalysts will need to be immobilized in order to:

- Reduce enzyme leakage in a flow system.
- Improve chemical stability of enzymes.
- Improve thermal stability of enzymes.

Three supportive matrices (i.e., carbon-, controlled pore glass [CPG]-, and silica-based materials) were evaluated for enzyme immobilization.

Since more than 60 to 70 percent of the process heat in the IVCAP is the stripping heat, an additive able to suppress water vaporization of the CO₂-loaded solution can reduce the stripping heat in the stripper. Successful screening and development of an additive can further reduce the heat use in the IVCAP.

The IVCAP has the flexibility to integrate SO₂ removal in the CO₂ capture process. In the amine-based and amine-promoted absorption processes, the flue gas must be treated to reduce the concentration of SO₂ and other acid gases to below 20 parts per million (ppm) to prevent/minimize the formation of heat-stable salts that are difficult to reclaim. In the IVCAP, SO₂ can be removed by the reaction with the solvent to form a sulfate salt that can be further processed to reclaim the solvent.

TABLE 2: PROCESS PARAMETERS FOR IVCAP PROCESS

	Units	Current R&D Value	Target R&D Value
Pure Solvent			
Molecular Weight	mol ⁻¹	138	N/A
Normal Boiling Point	°C	103	N/A
Normal Freezing Point	°C	≤0	N/A
Vapor Pressure @ 15°C	bar	Not volatile	N/A
Manufacturing Cost for Solvent	\$/kg	0.4-1.0	≤0.8
Working Solution			
Concentration	kg/kg	0.2	0.2
Specific Gravity (15°C/15°C)	-	1.24	N/A
Specific Heat Capacity @ STP	kJ/kg-K	3.34	N/A
Viscosity @ STP	cP	1.9	N/A
Absorption (Rich Solution at Bottom)			
Pressure	bar	0.06-0.08 (0.8-1.2 psia)	<0.1
Temperature	°C	40-60	40-60
Equilibrium CO ₂ Loading	mol/mol	0.5	0.5
Heat of Absorption	kJ/mol CO ₂	600	N/A
Solution Viscosity	cP	0.95 (at 50°C)	N/A
Desorption (Lean Solution at Bottom)			
Pressure (CO ₂ equilibrium pressure)	bar	0.007-0.02 (0.1-0.3 psia)	≥0.01
Temperature	°C	50-70	50-70
Equilibrium CO ₂ Loading	mol/mol	0.12-0.20	≤0.2
Heat of Desorption	kJ/mol CO ₂	600	N/A
Proposed Module Design		<i>(for equipment developers)</i>	
Flue Gas Flowrate	kg/hr	500,000 (100,000 kg/hr CO ₂)	
CO ₂ Recovery, Purity, and Pressure	% / % / bar	90%, 99%, 0.14–0.54 (prior to vacuum pump)	
Absorber Pressure Drop	bar	0.04 (structured packing)	
Estimated Absorber/Stripper Cost of Manufacturing and Installation	$\frac{\$}{\text{kg/hr}}$	N/A	

Definitions:

STP – Standard Temperature and Pressure (15°C, 1 atm).

Pure Solvent – Chemical agent(s), working alone or as a component of a working solution, responsible for enhanced CO₂ absorption (e.g., the amine MEA in an aqueous solution).

Manufacturing Cost for Solvent – “Current” is market price of chemical, if applicable; “Target” is estimated manufacturing cost for new solvents, or the estimated cost of bulk manufacturing for existing solvents.

Working Solution – The solute-free (i.e., CO₂-free) liquid solution used as the working solvent in the absorption/desorption process (e.g., the liquid mixture of MEA and water).

Absorption – The conditions of interest for absorption are those that prevail at maximum solvent loading, which typically occurs at the bottom of the absorption column. These may be assumed to be 1 atm total flue-gas pressure (corresponding to a CO₂ partial pressure of 0.13 bar) and 40°C; however, measured data at other conditions are preferable to estimated data.

Desorption – The conditions of interest for desorption are those that prevail at minimum solvent loading, which typically occurs at the bottom of the desorption column. Operating pressure and temperature for the desorber/stripper are process-dependent (e.g., an MEA-based absorption system has a typical CO₂ partial pressure of 1.8 bar and a reboiler temperature of 120°C). Measured data at other conditions are preferable to estimated data.

Pressure – The pressure of CO₂ in equilibrium with the solution. If the vapor phase is pure CO₂, this is the total pressure; if it is a mixture of gases, this is the partial pressure of CO₂. Note that for a typical pulverized coal (PC) power plant, the total pressure of the flue gas is about 1 atm and the concentration of CO₂ is about 13.2 percent. Therefore, the partial pressure of CO₂ is roughly 0.132 atm or 0.130 bar.

Concentration – Mass fraction of pure solvent in working solution.

Loading – The basis for CO₂ loadings is moles of pure solvent.

Estimated Cost – Basis is kg/hr of CO₂ in CO₂-rich product gas; assuming targets are met.

Other Parameter Descriptions:

Chemical/Physical Solvent Mechanism – The main reactions involving in the IVCAP include:

CO₂ absorption: $\text{CO}_2 + \text{H}_2\text{O} + \text{K}_2\text{CO}_3 = 2\text{KHCO}_3$

Solvent regeneration: $2\text{KHCO}_3 = \text{K}_2\text{CO}_3 + \text{H}_2\text{O} + \text{CO}_2$

Solvent Contaminant Resistance – Since the potassium carbonate solution is used as a solvent, no solvent degradation and little corrosion problems are expected. The K₂CO₃/KHCO₃ solution reacts with the flue gas contaminants (e.g., SO₂, nitrogen oxides [NO_x], hydrogen chloride [HCl], etc.). No SO₂ scrubbing pretreatment is needed prior to the IVCAP, since SO₂ removal can be combined with CO₂ capture and the potassium sulfate desulfurization product can be potentially reclaimed in the IVCAP.

Solvent Foaming Tendency – The K₂CO₃/KHCO₃ solution itself does not have a foaming problem. The addition of a carbonic anhydrase (CA) enzyme biocatalyst in the K₂CO₃/KHCO₃ solution will not incur a foaming tendency due to its low dosage (<3 g/l) and low contents of impurities.

Flue Gas Pretreatment Requirements – Sulfur dioxide removal can be combined with CO₂ capture in the IVCAP. The carbonate solution absorbs SO₂ to form a sulfate salt, which is reclaimable using a reclamation approach developed in this project. Therefore, a separate flue gas desulfurization (FGD) unit currently required in the power plant can be potentially downsized or even eliminated in the IVCAP. No other flue gas pretreatments (such as for particulate matter [PM], NO_x) are required either.

Solvent Make-Up Requirements – A thermophilic CA enzyme tested in the project demonstrated to be stable at 40°C. At 50°C, the enzyme had a half-life of approximately two months. After immobilization, the thermal stability of the enzyme has been significantly improved. The enzyme also demonstrated excellent chemical stability against the most abundant flue gas impurities. It is estimated that two to three replacements of the enzyme is required annually if the absorption operates at 50°C and 30 percent replacements is required at 40°C.

Waste Streams Generated – Waste streams mainly include the process blowdown streams, such as the carbonate/bicarbonate aqueous solution from the absorber/stripper and water condensate saturated with CO₂.

Proposed Module Design – Unless noted, flue gas feed pressure is 1.014 bara, temperature is 57°C, and composition leaving the flue gas desulfurization (FGD) unit (wet basis) should be assumed:

Composition (% vol)					Composition (ppmv)	
CO ₂	H ₂ O	N ₂	O ₂	Ar	SO _x	NO _x
13.17	17.25	66.44	2.34	0.8	42	74

technology advantages

- Uses lower-quality steam than amine-based processes (e.g., MEA), consequently increasing net power output.
- Lower heat of absorption.
- Less energy required for CO₂ stripping.
- Modified IVCAP may be able to remove SO₂ without an FGD unit.
- Approximately 25 percent lower electricity loss.

R&D challenges

- Slow kinetics of CO₂ absorption into the K₂CO₃ solution; thus, a high-activity catalyst is required.
- Potentially large capital and operating cost of the vacuum pump and vacuum stripper.
- Suppressing water vaporization in the stripper.
- Chemical and thermal stability of the absorption enzymes.

results to date/accomplishments

- Reactivity tests of two CA enzymes (ACA1 and ACA2) from a leading enzyme manufacturer and eight inorganic and organic catalysts commercially available were evaluated in a laboratory-stirred tank reactor (STR). The CA enzymes were identified to be the most-effective catalyst for promoting CO₂ absorption into K₂CO₃/KHCO₃ solution.
- Rates of CO₂ absorption into a 20 wt% K₂CO₃/KHCO₃ solution were increased by approximately three to nine times at temperatures between 25 and 50°C with the addition of 300 mg/l CA enzyme. Further increase in absorption rate was observed at higher CA concentrations (>300 mg/l CA). Absorption rates into CO₂-rich K₂CO₃/KHCO₃ solutions were comparable to those into CO₂-lean K₂CO₃/KHCO₃ solutions at the same CA dosage. Modeling predictions suggested that in a packed-bed column configuration, the IVCAP absorber at 2 g/l CA dosage was 23 to 40 percent larger than the equivalent equipment for the MEA process employing 5M MEA as a solvent.
- The CA enzymes demonstrated excellent chemical stability to resist flue gas impurities. Presence of flue gas impurities at their typical concentrations resulted in <11 percent loss of initial CA activity.
- The ACA1 enzyme had satisfactory stability at 25°C, but not at temperatures higher than 40°C. The ACA2 enzyme (a thermophilic CA) demonstrated excellent thermal stability at 40°C, losing only about 15 percent of its initial activity after six months. At 50°C, the ACA2 enzyme had a half-life of about two months.
- Covalent bonding methods were successfully developed to immobilize the CA enzymes onto different carbon-, CPG-, and silica-based support materials. All of the immobilized CA enzymes exhibited significantly improved thermal stability.
- Process simulation studies showed that the IVCAP integrated with a 528 MWe (gross) coal-fired, subcritical power plant at a baseline condition lowered parasitic power losses by 24 percent compared to the conventional MEA process.

- Techno-economic studies showed that the capital cost of the baseline IVCAP was about 33 percent higher than that for the MEA process due to the requirements for a vacuum pump and a larger stripper under a vacuum condition, but its operation and maintenance (O&M) cost was about 40 percent lower due to its lower solvent cost and reduced parasitic power losses. The levelized cost of electricity (LCOE, about \$46/MWh) of the baseline IVCAP was a 71 percent increase over the reference power plant without CO₂ capture, about 17 percent less than that of the MEA process.

next steps

This project ended on April 30, 2012.

available reports/technical papers/presentations

Zhang, S., et. al, "Catalytic Behavior of Carbonic Anhydrase Enzyme Immobilized onto Nonporous Silica Nanoparticles for Enhancing CO₂ Absorption into a Carbonate Solution," *Int. J. Greenhouse Gas Control* 2013, 13: 17-25.

Lu, Y., et. al, "Development and Evaluation of a Novel Integrated Vacuum Carbonate Absorption Process," Final Project Closeout Review, Pittsburgh, Pennsylvania, July 13, 2012. <http://www.netl.doe.gov/File%20Library/Research/Coal/ewr/co2/IVCAP-Closeout-Mtg-0713.pdf>.

Lu, Y., et al, "An Integrated Vacuum Carbonate Absorption Process Enabled with an Enzyme Biocatalyst for CO₂ Absorption," proceedings of the Clearwater Clean Coal Conference, Tampa, Florida, June 2012. <http://www.netl.doe.gov/File%20Library/Research/Coal/ewr/co2/Clearwater-IVCAP-YLu.pdf>.

Zhang S., et. al, "Activity and Stability of Immobilized Carbonic Anhydrase for Promoting CO₂ Absorption into A Carbonate Solution for Post-Combustion CO₂ Capture," *Bioresources Technology* 2011, 102(22): 10194-10201.

Lu, Y., et. al, "Development of a Carbonate Absorption-Based Process for Post-Combustion CO₂ Capture: The Role of Biocatalyst to Promote CO₂ Absorption Rate," *Energy Procedia* 2011, 4: 1286-1293.

Lu, Y., et. al, "Development and Evaluation of a Novel Integrated Vacuum Carbonate Absorption Process," presented at the 2011 NETL CO₂ Capture Technology Meeting, Pittsburgh, Pennsylvania, August 2011.

Lu, Y., et.al, "Development and Evaluation of a Novel Integrated Vacuum Carbonate Absorption Process," presented at the 2010 NETL CO₂ Capture Technology Meeting, Pittsburgh, Pennsylvania, September 2010.

Lu, Y., "Development and Evaluation of a Novel Integrated Vacuum Carbonate Absorption Process," presented at the Annual NETL CO₂ Capture Technology for Existing Plants R&D Meeting, Pittsburgh, Pennsylvania, March 2009.

SLIPSTREAM DEVELOPMENT AND TESTING OF SIEMENS POSTCAP CAPTURE AND SEPARATION TECHNOLOGY

primary project goals

Siemens Energy set out to design, install, and operate a pilot plant to treat a 2.5-megawatt (MW) flue gas slipstream from an operating coal-fired power plant to demonstrate the aqueous amino acid salt (AAS) solvent-based, post-combustion carbon dioxide (CO₂) gas capture technology.

technical goals

- Demonstrate the ability of Siemens Energy's POSTCAP technology to achieve 90 percent CO₂ removal while approaching a 35 percent increase in the cost of electricity (COE).
- Demonstrate the scalability and feasibility of developing the technology to a full-scale, commercial, post-combustion CO₂ capture (550 MW) application for coal-fired power plants and to full-scale commercial application for industrial sources of CO₂ emissions.

technical content

Siemens Energy worked to design, install, and operate an advanced CO₂ capture, solvent-based pilot plant. The Siemens POSTCAP CO₂ capture process utilizes an aqueous AAS solution as the solvent that offers cost and performance advantages when compared to state-of-the-art, amine-based solvents. The POSTCAP pilot plant was to be installed at Tampa Electric Company's (TECO) Big Bend Station and treat a flue gas slipstream equivalent to approximately 2.5 megawatt electric (MWe). Although the CO₂ source for this slipstream pilot-scale testing is from a coal-fired power plant flue gas, it would have provided an appropriate design and performance baseline for direct scale-up to many industrial applications.

The project encompassed the complete design, engineering, procurement, installation, operation, data analysis, and decommissioning of the CO₂ capture system and was to be completed in four phases. In Phase I, the engineering design and permitting for the project were completed. POSTCAP system mass and energy balances and pilot plant process flow diagrams were to be generated, and the host site was to be analyzed for integration of the pilot plant. Phase II was to encompass the equipment procurement, fabrication, delivery, and installation of the components at the host site with required tie-ins to plant interfaces. In Phase III, the pilot plant was to be commissioned and started up, the pilot program test campaigns were to be conducted, and the resulting data were to be analyzed. Phase IV was to cover the pilot plant decommissioning and disassembly.

technology maturity:

Pilot-Scale, Actual Flue Gas Slipstream

project focus:

POSTCAP Capture and Separation

participant:

Siemens Energy

project number:

FE0003714

NETL project manager:

David Lang
david.lang@netl.doe.gov

principal investigator:

John Winkler
Siemens Energy, Inc.
john.winkler@siemens.com

partners:

Siemens AG

performance period:

10/1/10 – 2/29/12



Figure 1: Siemens Lab Plant for CO₂ Capture Tests at Frankfurt Hoechst Industrial Park

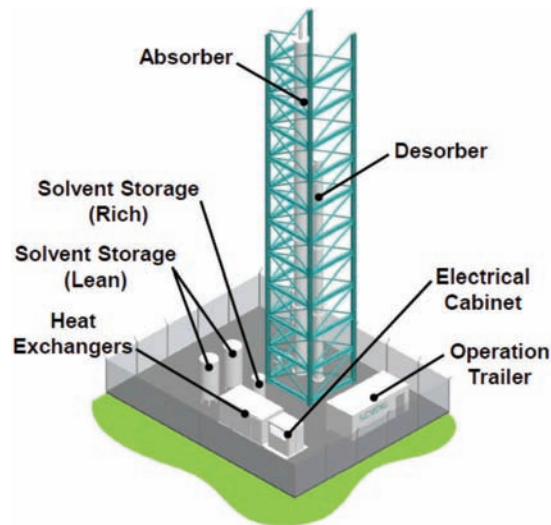

Figure 2: Basic POSTCAP Pilot Layout

technology advantages

- Lower energy consumption.
- Negligible solvent emission and degradation.
- High absorption capacity.
- Low environmental impact.

R&D challenges

- Developing solvent suppliers on a large, commercial scale.
- Minimize energy consumption.
- Available footprint for large-scale carbon capture retrofits.
- Combined cycle challenges to be overcome:
 - Low CO₂ concentration in flue gas.
 - High oxygen content in flue gas.
 - Operation with frequent load changes.
 - Fewer integration options for low-temperature heat from the capture plant.

results to date/accomplishments

Completed a preliminary design for a 2.5-MW POSTCAP pilot plant that was to be installed at the TECO Big Bend Power Station.

next steps

This project ended on February 29, 2012.

available reports/technical papers/presentations

Winkler, J.L., “Slipstream Development & Testing of Post Combustion CO₂ Capture and Separation Technology for Existing Coal-Fired Plants,” presented at 2011 NETL CO₂ Capture Technology Meeting, Pittsburgh, Pennsylvania, August 2011. <http://www.netl.doe.gov/publications/proceedings/11/co2capture/presentations/2-Tuesday/23Aug11-Winkler-Siemens-Technology%20Slipstream%20Testing.pdf>.

REVERSIBLE IONIC LIQUIDS AS DOUBLE-ACTION SOLVENTS FOR EFFICIENT CO₂ CAPTURE

primary project goals

The primary project goal was to develop a novel class of solvents for the recovery of carbon dioxide (CO₂) from post-combustion flue gases that would achieve a substantial increase in CO₂ working capacity with a reduction in cost.

technical goals

- Synthesis of silyl amine-based ionic liquids (ILs) with minimal viscosity.
- Measure heat of absorption and desorption.
- Measure rates of CO₂ absorption and desorption.
- Identify solvents that will consume the minimal amount of energy.
- Use simulation tools, such as ASPEN, to design an economic absorption/desorption process.

technical content

Reversible ionic liquids (RevILs) are neutral molecules that react with CO₂ to form an IL, which then dissolves additional CO₂ by a physisorption mechanism. Subsequently, modest elevations in temperature reverse the reaction and yield pure CO₂ for disposal; because of this dual mode, capacity can be large.

In a two-component RevIL, CO₂ at 1 atmosphere acts as a “switch,” as shown in Figure 1.

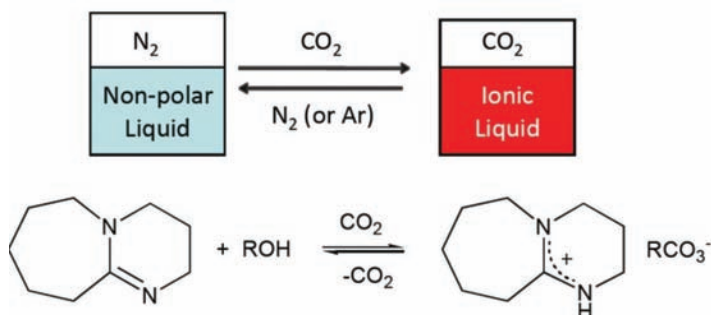

Figure 1: CO₂ Will Switch a Non-Polar Liquid to an Ionic Liquid

Two-component RevILs have the disadvantage of being too complex and requiring alcohol. Light alcohol would evaporate with the CO₂, while a heavy alcohol would have too much heat capacity. A single-component RevIL would eliminate the need for alcohol.

Figure 2 shows an example based on silylated amine. The chemistry must work well in the presence of water, considering that water is a component of flue gas. The RevILs will be tested for their chemical stability with 0 and 10 % water present. Stability will also be tested

technology maturity:

**Laboratory-Scale,
Simulated Flue Gas**

project focus:

Reversible Ionic Liquids

participant:

**Georgia Tech Research
Corporation**

project number:

NT0005287

NETL project manager:

David Lang
david.lang@netl.doe.gov

principal investigator:

Charles A. Eckert
**Georgia Tech Research
Corporation**
charles.eckert@chbe.gatech.edu

partners:

N/A

performance period:

10/1/08 – 9/30/11

at 4, 25, and 50°C. High viscosity could also be an issue; however, viscosity in RevILs is highly nonlinear (as shown in Figure 3) and can be reduced with impurities, such as water or dissolved gases.

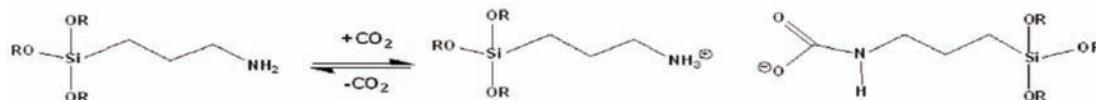

Figure 2: An Example of a Single-Component RevIL

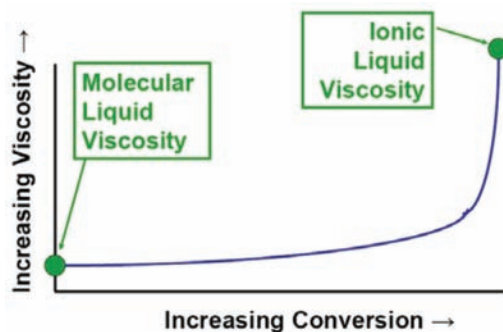

Figure 3: Ionic Liquids are More Viscous Than Their Respective Molecular Liquids

TABLE 1: PROCESS PARAMETERS FOR REVIL SOLVENTS

	Units	Current R&D Value	Target R&D Value
Pure Solvent			
Molecular Weight	mol ⁻¹	170-220	150
Normal Boiling Point	°C	150 or greater	200
Normal Freezing Point	°C	< -77	
Vapor Pressure @ 15°C	bar	0.5-1x10 ⁻³	
Manufacturing Cost for Solvent	\$/kg	TBD	
Working Solution			
Concentration	kg/kg	0.95	
Specific Gravity (15°C/15°C)	-	≈0.82	
Specific Heat Capacity @ STP	kJ/kg-K	2.2	<4.2
Viscosity @ STP	cP	>1,000	<80
Absorption			
Pressure	bar	1.2	1.2
Temperature	°C	25-40	>50
Equilibrium CO ₂ Loading	mol/mol	Avg. 0.63	
Heat of Absorption	kJ/mol CO ₂	80-90	
Solution Viscosity	cP	Variable (often <1,000)	<1,000
Desorption			
Pressure	bar	2	2
Temperature	°C	115	75
Equilibrium CO ₂ Loading	mol/mol	< 0.01	
Heat of Desorption	kJ/mol CO ₂	≈120	

TABLE 1: PROCESS PARAMETERS FOR REVIL SOLVENTS

	Units	Current R&D Value	Target R&D Value
Proposed Module Design		<i>(for equipment developers)</i>	
Flue Gas Flowrate	kg/hr		
CO ₂ Recovery, Purity, and Pressure	% / % / bar		
Absorber Pressure Drop	bar		
Estimated Absorber/Stripper Cost of Manufacturing and Installation	\$		
	kg/hr		

Definitions:

STP – Standard Temperature and Pressure (15°C, 1 atm).

Pure Solvent – Chemical agent(s), working alone or as a component of a working solution, responsible for enhanced CO₂ absorption (e.g., the amine monoethanolamine [MEA] in an aqueous solution).

Manufacturing Cost for Solvent – “Current” is market price of chemical, if applicable; “Target” is estimated manufacturing cost for new solvents, or the estimated cost of bulk manufacturing for existing solvents.

Working Solution – The solute-free (i.e., CO₂-free) liquid solution used as the working solvent in the absorption/desorption process (e.g., the liquid mixture of MEA and water).

Absorption – The conditions of interest for absorption are those that prevail at maximum solvent loading, which typically occurs at the bottom of the absorption column. These may be assumed to be 1 atm total flue-gas pressure (corresponding to a CO₂ partial pressure of 0.13 bar) and 40°C; however, measured data at other conditions are preferable to estimated data.

Desorption – The conditions of interest for desorption are those that prevail at minimum solvent loading, which typically occurs at the bottom of the desorption column. Operating pressure and temperature for the desorber/stripper are process-dependent (e.g., an MEA-based absorption system has a typical CO₂ partial pressure of 1.8 bar and a reboiler temperature of 120°C). Measured data at other conditions are preferable to estimated data.

Pressure – The pressure of CO₂ in equilibrium with the solution. If the vapor phase is pure CO₂, this is the total pressure; if it is a mixture of gases, this is the partial pressure of CO₂. Note that for a typical pulverized coal (PC) power plant, the total pressure of the flue gas is about 1 atm and the concentration of CO₂ is about 13.2 percent. Therefore, the partial pressure of CO₂ is roughly 0.132 atm or 0.130 bar.

Concentration – Mass fraction of pure solvent in working solution.

Loading – The basis for CO₂ loadings is moles of pure solvent.

Estimated Cost – Basis is kg/hr of CO₂ in CO₂-rich product gas; assuming targets are met.

Other Parameter Descriptions:

Chemical/Physical Solvent Mechanism – Chemical reaction for the CO₂ capture process is shown in Figure 2.

Solvent Contaminant Resistance – Since amine groups are involved in the reaction, sulfur oxides (SO_x) and nitrogen oxides (NO_x), as well as other acid gases, have to be removed. However, solvents have been shown to be stable in wet and oxygen-rich environments for a period of two months.

Solvent Foaming Tendency – No foaming observed.

Flue Gas Pretreatment Requirements – Flue gas pretreatment should be similar to the amine-based absorption processes since the RevIL is resistant to moisture.

Solvent Make-Up Requirements – Only required for process leakage in large plant.

Waste Streams Generated – None anticipated.

Proposed Module Design – Unless noted, flue gas feed pressure is 1.014 bara, temperature is 57°C, and composition leaving the flue gas desulfurization (FGD) unit (wet basis) should be assumed:

Composition (% vol)					Composition (ppmv)	
CO ₂	H ₂ O	N ₂	O ₂	Ar	SO _x	NO _x
13.17	17.25	66.44	2.34	0.8	42	74

technology advantages

- Use both physical absorption (dissolution in RevILs) and chemical absorption (reaction with RevILs); amines utilize only chemical absorption.
- Structure can be modified to optimize properties.
- Silylation will decrease viscosity.
- Function in the presence of water.
- Greater capacity than current solvents.
- Smaller energy penalty than current solvents.

R&D challenges

- New compounds must be designed, synthesized, and characterized.
- Optimum equilibria and heats must be achieved.
- Rapid reaction rates must be achieved.
- Favorable transport rates must be achieved.
- Results from new process must meet U.S. Department of Energy goals.

results to date/accomplishments

- Have demonstrated greater capacity than current solvents.
- Successful synthesis and chemical characterization of 10 precursors for novel RevILs:
 - (3-aminopropyl) trimethoxysilane.
 - (3-aminopropyl) triethoxysilane.
 - (3-aminopropyl) triethylsilane.
 - (3-aminopropyl) tripropylsilane.
 - (3-aminopropyl) trihexylsilane.
 - (3-aminopropyl) diisopropyl silane.
 - (3-aminopropyl) cyclohexyldimethyl silane.
 - (3-aminopropyl) phenyldimethyl silane.
 - (E)-3-(triethylsilyl) prop-2-en-1-amine.
 - 4-(triethylsilyl) butan-2-amine.
- Completed examination of the chemical and physical absorption of CO₂ in the six silyl-amine-based RevILs at operating pressures of up to 1,000 pounds per square inch (psi) and temperatures of 35, 50, 75, and 100°C.
- Established recyclability of silyl-amine-based reversible ILs.

next steps

This project ended on September 30, 2011.

available reports/technical papers/presentations

Rohan, A. L., et.al, "The Synthesis and the Chemical and Physical Properties of Non-Aqueous Silylamine Solvents for Carbon Dioxide Capture," *Chemsuschem* 2012, 5 (11), 2181-2187.

Eckert, C. A., and Liotta, C. L., "Reversible Ionic Liquids as Double-Action Solvents for Efficient CO₂ Capture," Final Report, December 2011. <http://www.osti.gov/bridge/servlets/purl/1048880/1048880.pdf>.

Eckert, C. A., and Liotta, C. L., "Reversible Ionic Liquids as Double-Action Solvents for Efficient CO₂ Capture," presented at 2010 NETL CO₂ Capture Technology Meeting, Pittsburgh, Pennsylvania, September 2010. <http://www.netl.doe.gov/publications/proceedings/10/co2capture/presentations/monday/Charles%20Eckert-NT0005287.pdf>.

Blasucci, V., et.al, "Single Component, Reversible Ionic Liquids for Energy Applications," *Fuel*, 89, 1315–1319, 2010.

Blasucci, V., et.al, "Reversible Ionic Liquids Designed for Facile Separations," *Fluid Phase Equilibria*, 294, 1-6, 2010.

Hart, R., et.al, "Benign Coupling of Reactions and Separations with Reversible Ionic Liquids," *Tetrahedron*, 66, 1082-1090, 2010.

Eckert, C. A., and Liotta, C. L., "Reversible Ionic Liquids as Double-Action Solvents for Efficient CO₂ Capture," presented at the Annual NETL CO₂ Capture Technology for Existing Plants R&D Meeting, Pittsburgh, Pennsylvania, March 2009. <http://www.netl.doe.gov/publications/proceedings/09/CO2/pdfs/5287%20Georgia%20Tech%20reversible%20IL%20solvent%20%28Eckert%29%20mar09.pdf>.

Blasucci, V., et.al, "One Component, Switchable, Neutral to Ionic Liquid Solvents Derived from Siloxylated Amines," *Chem Comm*, 116-119, 2009.

CO₂ CAPTURE FROM FLUE GAS BY PHASE TRANSITIONAL ABSORPTION

primary project goals

Hampton University set out to conduct the kinetic study for its novel technology, phase transitional absorption, which has the potential to reduce operation costs by at least half (possibly by 80%) and significantly cut capital investment (compared with current monoethanolamine [MEA]-carbon dioxide [CO₂] absorption technologies).

technical goals

To understand the mechanisms of phase transitional absorption by measuring absorption kinetics, regeneration rate, and loading capacity, as well as to further compare with other methods, such as the state-of-art MEA absorption.

technical content

The phase transitional absorption process is radically different from the conventional absorption processes. It uses an activated agent, which, when mixed with a special solvent, forms a special phase transitional absorbent for CO₂ capture. The absorbent, after absorbing CO₂ from flue gas in an absorber, flows into a settler where it is separated into two phases: a CO₂-rich phase and a CO₂-lean phase. The CO₂-rich solvent is then sent to a regenerator for regeneration. After regeneration, the solvent is cooled and mixed with the CO₂-lean phase and sent to an absorber to complete the cycle.

A schematic diagram of the process is shown in Figure 1. It may be noted that the process is similar to a conventional MEA process, except that a settler is added for separating the two phases.

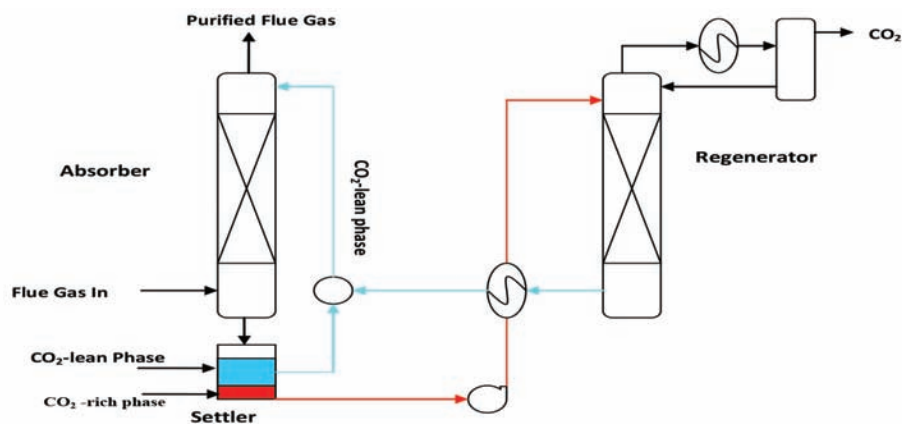

Figure 1: Concept Flow Diagram of Phase Transitional Absorption

In the conventional absorption process, such as an MEA process, the entire solvent is sent to the regenerator for regeneration, which necessitates a large circulation pump and a large amount of regeneration energy. In contrast, in the phase transitional absorption process, the

technology maturity:

Laboratory-Scale, Using Simulated Flue Gas

project focus:

Phase Transitional Absorption

participant:

Hampton University

project number:

FG26-05NT42488

NETL project manager:

Isaac Aurelio

isaac.aurelio@netl.doe.gov

principal investigator:

Liang Hu

Hampton University

lianghu59@yahoo.com

partners:

None

performance period:

6/15/05 – 6/30/09

absorbent separates into two phases, and only the CO₂-rich phase needs to be regenerated. The CO₂-rich phase is only approximately 20 percent of the total absorbent. Thus, the pumping and heating requirements are significantly less compared to the MEA process.

Another important feature of the phase transitional absorption is that the absorption rate of CO₂ will be enhanced by selecting the proper solvent, as shown in Figure 2.

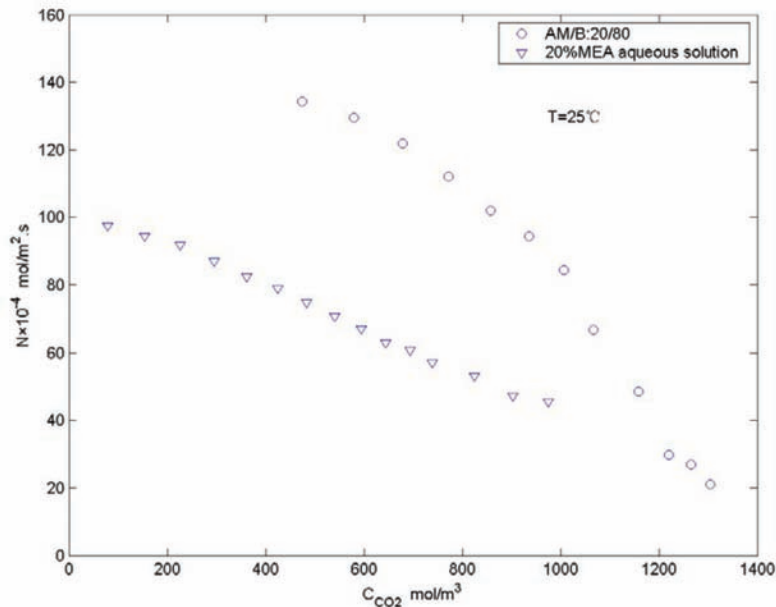

Figure 2: Absorption Rate Comparison (Phase Transitional Absorption vs. MEA Technology)

T = 25°C; P_{CO2} = 1 atm; N=60 rpm; VL = 900 ml.
 Phase Transitional Absorption: activated agent: AM 20 percent by volume; solvent: B 80 percent.
 MEA Technology: 20 percent (by volume) MEA aqueous solution.

Experimental results also showed that the temperature did not have strong impact on the absorption rate for the several absorbents studied. The small effect on the absorption rate by temperature could be attributed to the much smaller reaction heat.

The highest absorption rate is found when the activated agent was in the range of 30 to 40 percent by volume. The range may vary if the different activated agents and solvents are used. The range of activated agents with the highest absorption rate is highly related to the physical and chemical properties of the absorbent (i.e., activated agents and solvents), as well as the combination.

It was determined from these results that the mechanism of the absorption is a fast chemical reaction controlled by the liquid-side mass transfer. Therefore, an absorber with large gas-liquid interface and sufficient liquid turbulence is recommended in order to have a higher absorption rate, such as a packed column.

TABLE 1: PARAMETERS FOR PHASE TRANSITIONAL ABSORPTION PROCESSES

	Units	Current R&D Value	Target R&D Value
Pure Solvent			
Molecular Weight	mol ⁻¹	varies	
Normal Boiling Point	°C	varies	
Normal Freezing Point	°C	N/A	
Vapor Pressure @ 15°C	bar	N/A	
Manufacturing Cost for Solvent	\$/kg	N/A	

TABLE 1: PARAMETERS FOR PHASE TRANSITIONAL ABSORPTION PROCESSES

	Units	Current R&D Value	Target R&D Value
Working Solution			
Concentration	kg/kg	20/80 by volume	
Specific Gravity (15°C/15°C)	-	N/A	
Specific Heat Capacity @ STP	kJ/kg-K	N/A	
Viscosity @ STP	cP	N/A	
Absorption			
Pressure	bar	1	
Temperature	°C	25-50	
Equilibrium CO ₂ Loading	mol/mol	0.4 – 0.5	
Heat of Absorption	kJ/mol CO ₂	N/A	
Solution Viscosity	cP	N/A	
Desorption			
Pressure	bar	1	
Temperature	°C	90-120	
Equilibrium CO ₂ Loading	mol/mol	≈ 0	
Heat of Desorption	kJ/mol CO ₂	N/A	
Proposed Module Design		<i>(for equipment developers)</i>	
Flue Gas Flowrate	kg/hr		N/A
CO ₂ Recovery, Purity, and Pressure	% / % / bar		N/A
Absorber Pressure Drop	bar		N/A
Estimated Absorber/Stripper Cost of Manufacturing and Installation	$\frac{\$}{\text{kg/hr}}$		N/A

Definitions:

STP – Standard Temperature and Pressure (15°C, 1 atm).

Pure Solvent – Chemical agent(s), working alone or as a component of a working solution, responsible for enhanced CO₂ absorption (e.g., the amine MEA in an aqueous solution).

Manufacturing Cost for Solvent – “Current” is market price of chemical, if applicable; “Target” is estimated manufacturing cost for new solvents, or the estimated cost of bulk manufacturing for existing solvents.

Working Solution – The solute-free (i.e., CO₂-free) liquid solution used as the working solvent in the absorption/desorption process (e.g., the liquid mixture of MEA and water).

Absorption – The conditions of interest for absorption are those that prevail at maximum solvent loading, which typically occurs at the bottom of the absorption column. These may be assumed to be 1 atm total flue-gas pressure (corresponding to a CO₂ partial pressure of 0.13 bar) and 40°C; however, measured data at other conditions are preferable to estimated data.

Desorption – The conditions of interest for desorption are those that prevail at minimum solvent loading, which typically occurs at the bottom of the desorption column. Operating pressure and temperature for the desorber/stripper are process-dependent (e.g., an MEA-based absorption system has a typical CO₂ partial pressure of 1.8 bar and a reboiler temperature of 120°C). Measured data at other conditions are preferable to estimated data.

Pressure – The pressure of CO₂ in equilibrium with the solution. If the vapor phase is pure CO₂, this is the total pressure; if it is a mixture of gases, this is the partial pressure of CO₂. Note that for a typical PC power plant, the total pressure of the flue gas is about 1 atm and the concentration of CO₂ is about 13.2 percent. Therefore, the partial pressure of CO₂ is roughly 0.132 atm or 0.130 bar.

Concentration – Mass fraction of pure solvent in working solution.

Loading – The basis for CO₂ loadings is moles of pure solvent.

Estimated Cost – Basis is kg/hr of CO₂ in CO₂-rich product gas; assuming targets are met.

Other Parameter Descriptions:

Chemical/Physical Solvent Mechanism – The mechanism of the absorption is a fast chemical reaction controlled by the liquid-side mass transfer.

technology advantages

- Greatly reducing regeneration energy compared with the MEA process.
- Higher absorption rate, resulting in lower capital investment for absorption equipment.
- Higher CO₂ working capacity, which will reduce sensible heat and solvent volume in circulation.
- Low corrosion rate to carbon steel compared to the MEA process.
- Potentially less solvent loss.
- Non-toxic, environmentally safe.

R&D challenges

- Process exists only at the laboratory scale and needs to be scaled-up.
- Moisture in flue gas may have impact on the process.

results to date/accomplishments

- Measured the absorption rate at 15, 25, 35, 45, and 55 °C.
- Measured the effect of absorbent concentration in solution (from 10 to 50 percent by volume) on absorption rate and loading capacity.
- Measured the effect of solution agitation speed (30, 60, and 90 rpm) on absorption rate.
- Measured the absorption rate at 1 atm of CO₂ partial pressure.
- Conducted the regeneration tests; measured the regeneration rate at different temperature.
- Conducted the corrosion tests for carbon steel coupon.
- Conduct the initial process evaluation based on the lab results and made the comparison with MEA absorption.

next steps

This project ended on June 30, 2009.

available reports/technical papers/presentations

Hu, L., "CO₂ Capture from Flue Gas by Phase Transitional Absorption." Final Report June 2009. <http://www.netl.doe.gov/File%20Library/Research/Coal/ewr/co2/phase-transitional-absorption-final-report-june2009.pdf>.

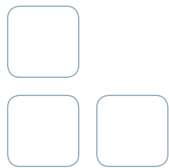

POST-COMBUSTION SORBENT TECHNOLOGIES



PILOT-SCALE EVALUATION OF AN ADVANCED CARBON SORBENT-BASED PROCESS FOR POST-COMBUSTION CARBON CAPTURE

primary project goals

SRI International is designing, building, and operating a slipstream 0.5-MWe pilot-scale test unit for post-combustion carbon dioxide (CO₂) capture to demonstrate their process using a novel low-cost, low-energy, and high-capacity carbon sorbent in a single column integrating both the absorber and desorber.

technical goals

- Operate SRI's 40-kWe sorbent test unit on actual flue gas at the National Carbon Capture Center (NCCC) to provide data for initial techno-economic assessment and for pilot plant design.
- Design 0.5-MWe slipstream pilot plant for post-combustion CO₂ capture using novel sorbent.
- Fabricate pilot plant and install onsite at NCCC.
- Parametric testing on steady state operation at pilot plant.
- Update techno-economic assessment and EH&S assessment based on data from pilot plant testing.
- Develop scaleup plan to implement technology at commercial-scale plant.
- Finalize sorbent formulation and method of manufacture.

technical content

SRI International is designing, building, and operating a slipstream 0.5-MWe pilot-scale process for post combustion CO₂ capture using their novel carbon sorbent. The technology is based on the sorbent developed on the bench-scale in a previously funded DOE project NT0005578. The novel sorbent developed for the project, manufactured by ATMI, Inc., is composed of carbon microbeads, as shown in Figure 1. These microbeads show excellent CO₂ capacity and selectivity, fast adsorption/desorption kinetics, and good resistance to agglomeration and attrition, allowing for reductions in both capital and operating expenses. Reduced steam regeneration requirements in the process can reduce the parasitic power load.

technology maturity:

Pilot-Scale, Actual Flue Gas Slipstream (0.5 MWe)

project focus:

Novel Solid Sorbent

participant:

SRI International

project number:

FE0013123, NT0005578

NETL project manager:

Andrew Jones
andrew.jones@netl.doe.gov

principal investigator:

Marc Hornbostel
SRI International
marc.hornbostel@sri.com

partners:

ATMI, Inc.
Linde, LLC
Electric Power Research Institute

performance period:

10/1/08– 3/31/18

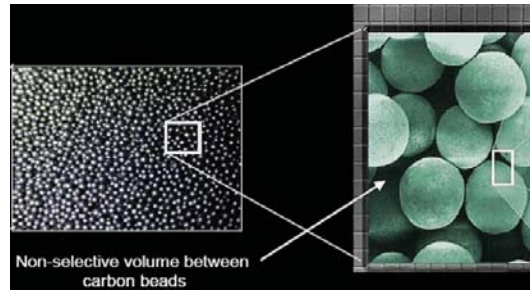

Figure 1: Graphic Displays of Novel Carbon Pellets Sorbent

Figure 2 depicts the proposed sorbent system for an existing coal-fired power plant. Flue gas first enters an existing flue gas desulfurization (FGD) system where most of the sulfur content is removed. The gas is then cooled before entering the Falling Bed adsorption reactor, which utilizes a high-capacity carbon sorbent (0.05–0.08 kg of CO₂ per kg of sorbent). As the gas stream passes over the lean sorbent, CO₂ is removed from the gas and adsorbed by the sorbent. The loaded sorbent cascades down the separation column and is heated by low-pressure steam, causing the sorbent to release the adsorbed CO₂. The CO₂ is siphoned off to a compressor where it can be prepared for sequestration. The sorbent is then dried, cooled, and sent back into the separation column for reuse and the cycle begins again.

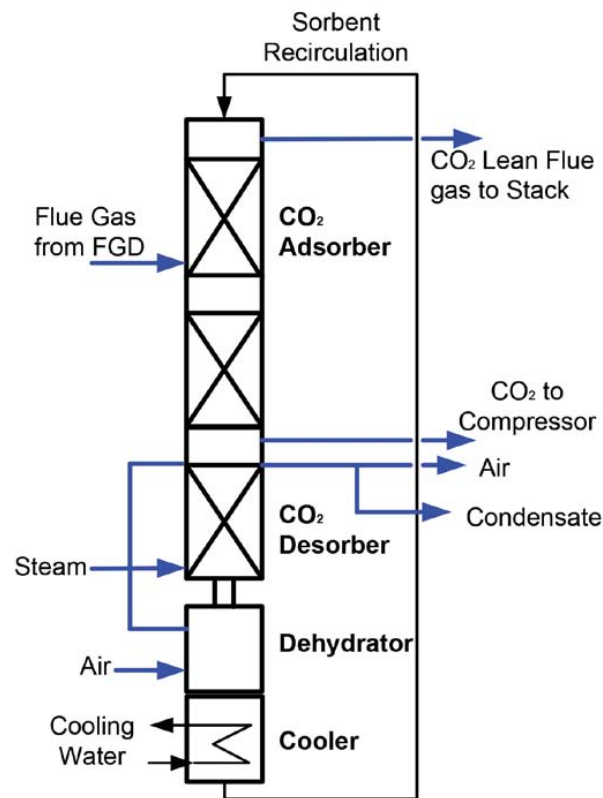

Figure 2: The Sorbent System

Testing on the 0.5-MWe pilot-scale system installed at NCCC site using carbon-fired flue gas provides data to perform a techno-economic assessment and scaleup strategy. The project aims to establish the technical and economic feasibility of using this novel carbon sorbent technology for post-combustion capture of CO₂ from coal-fired power plants with 90 percent capture efficiency and 95 percent CO₂ purity at a cost of \$40/tonne of CO₂ captured.

The sorbent and process parameters identified to date are provided in Table 1.

TABLE 1: PROCESS PARAMETERS FOR SRI SORBENT

	Units	Current R&D Value	Target R&D Value
Sorbent			
True Density at STP	kg/m ³	1,100	1,100
Bulk Density	kg/m ³	700	700
Average Particle Diameter	mm	0.2	0.2
Particle Void Fraction	m ³ /m ³	0.45	0.45
Packing Density	m ² /m ³	1.1 X 10 ⁹	1.1 X 10 ⁹
Solid Heat Capacity at STP	kJ/kg-K	1.0	1.0
Crush Strength	MPa	83	83
Manufacturing Cost for Sorbent	\$/kg	Proprietary	
Adsorption			
Pressure	bar	1	1
Temperature	°C	20	20
Equilibrium Loading	g mol CO ₂ /kg	4	4
Heat of Adsorption	kJ/mol CO ₂	27	27
Desorption			
Pressure	bar	1	1
Temperature	°C	100	100
Equilibrium Loading	g mol CO ₂ /kg	0.96	0.96
Heat of Desorption	kJ/mol CO ₂	27	27
Proposed Module Design		<i>(for equipment developers)</i>	
Flow Arrangement/Operation	—	continuous, moving bed	
Flue Gas Flowrate	kg/hr	1,860	
CO ₂ Recovery, Purity, and Pressure	%/%/bar	90/95/1	
Adsorber Pressure Drop	bar	0.005	

Definitions:

STP – Standard Temperature and Pressure (15°C, 1 atm).

Sorbent – Adsorbate-free (i.e., CO₂-free) and dry material as used in adsorption/desorption cycle.

Manufacturing Cost for Sorbent – “Current” is market price of material, if applicable; “Target” is estimated manufacturing cost for new materials, or the estimated cost of bulk manufacturing for existing materials.

Adsorption – The conditions of interest for adsorption are those that prevail at maximum sorbent loading, which typically occurs at the bottom of the adsorption column. These may be assumed to be 1 atm total flue-gas pressure (corresponding to a CO₂ partial pressure of 0.13 bar) and 40 °C; however, measured data at other conditions are preferable to estimated data.

Desorption – The conditions of interest for desorption are those that prevail at minimum sorbent loading, which typically occurs at the bottom of the desorption column. Operating pressure and temperature for the desorber/stripper are process-dependent. Measured data at other conditions are preferable to estimated data.

Pressure – The pressure of CO₂ in equilibrium with the sorbent. If the vapor phase is pure CO₂, this is the total pressure; if it is a mixture of gases, this is the partial pressure of CO₂. Note that for a typical PC power plant, the total pressure of the flue gas is about 1 atm and the concentration of CO₂ is about 13.2 percent. Therefore, the partial pressure of CO₂ is roughly 0.132 atm or 0.130 bar.

Packing Density – Ratio of the active sorbent area to the bulk sorbent volume.

Loading – The basis for CO₂ loadings is mass of dry, adsorbate-free sorbent.

Flow Arrangement/Operation – Gas-solid module designs include fixed, fluidized, and moving bed, which result in either continuous, cyclic, or semi-regenerative operation.

Other Parameter Descriptions:

Chemical/Physical Sorbent Mechanism – Rapid physical adsorption and desorption rates: The adsorption of CO₂ occurs on the micropores of the sorbent with low activation energy (<5 kJ/mole), allowing rapid equilibrium. Similarly, the adsorbed CO₂ is desorbed rapidly at the regeneration temperature (≈100 °C), and the sorbent performance can be predicted by equilibrium models.

Sorbent Contaminant Resistance – The sorbent is pure carbon and generally resistant to many contaminants. The sulfur dioxide (SO₂) needs to be reduced to <10 parts per million (ppm) levels, preferably to 1 ppm level. Nitrogen oxides (NO_x) can be present at ≈50 ppm levels. Fly-ash particles in flue gas downstream of an electrostatic precipitator do not appear to interfere with CO₂ adsorption.

Sorbent Attrition and Thermal/Hydrothermal Stability – The sorbent granules are hard and attrition-resistant. No observable attrition was noticed in a recent field test conducted over 7,000 cycles of adsorption and regeneration. The sorbent has a high hydro-thermal stability and direct heating with steam can be used for CO₂ desorption. The sorbent regenerated at the elevated temperature can be cooled by evaporative cooling of moisture adsorbed on the sorbent.

Flue Gas Pretreatment Requirements – Reduce SO₂ levels to <5 ppm. The flue gas needs to be cooled to ≈25°C.

Sorbent Makeup Requirements – Preliminary data suggest multi-year lifetime for sorbent makeup.

Waste Streams Generated – The sorbent particles are hard and attrition-resistant, and no fine sorbent particles are generated during operation. Steam condensate from the dehydrator may need to be treated before cycling back to the steam boiler.

Proposed Module Design – The module will be located between FGD and flue gas chimney.

technology advantages

- Low cost carbon sorbent.
- Low activation energy and rapid cycling for adsorption/desorption.
 - Reduced capital and operating costs.
- The sorbent has a high capacity for CO₂ adsorption (20 wt% at 1 atm CO₂) and good selectivity for CO₂ over other flue gas components (CO₂-N₂ separation factor >20).
- Low heat capacity minimizes thermal energy required to heat the sorbent to regeneration temperature.
- Carbon sorbent particles have excellent attrition resistance, minimal dust generation, and high resistance to agglomeration.
- High hydrothermal stability: Direct heating with steam can be used for CO₂ desorption. The sorbent regenerated at the elevated temperature can be cooled by evaporative cooling of moisture adsorbed on the sorbent.
- High thermal conductivity: The thermal conductivity of 0.8 W/m-K enables rapid thermal equilibrium between the surface and interior of the microbeads.
- The sorbent is essentially hydrophobic, indicating little interaction between the condensed water and the sorbent. The thermal energy required to desorb the condensed water is significantly less than that required to evaporate water from oxide surfaces such as those found in molecular sieves (zeolites), alumina, and silica.
- Continuous, falling microbead sorbent reactor geometry integrates the adsorber and stripper in a single vertical column.
 - Low pressure drop for gas flow.
 - Minimal physical handling of solvent.

R&D challenges

- Other elements of the flue gas, such as sulfur oxides (SO_x), may compete with CO₂ in being adsorbed by the sorbent, reducing the amount of CO₂ that is adsorbed as the gas passes through the reactor.
- A low temperature needs to be maintained for optimal adsorption conditions. The flue gas needs to be cooled to approximately 25°C.

results to date/accomplishments

- Completed the long-term, 1,000-cycle test to determine the durability of the sorbent.
- Completed bench-scale parametric tests and evaluation of optimum process conditions.
- Completed field testing with their bench-scale unit using flue gas from a coal-fired boiler at the University of Toledo. Testing ended after 135 hours (approximately 7,000 cycles of adsorption and desorption).
- Evaluated several physical, chemical, and mechanical properties of the sorbent in the context of the CO₂ capture system using a bench-scale, fixed-bed reactor.
- Demonstrated regeneration using direct contact steam producing relatively pure CO₂.
- Simulated CO₂ capture using novel carbon sorbent in a pulverized coal (PC)-fired boiler from coal to electricity and compressed CO₂.
- Determined several physical and chemical properties of the advanced carbon sorbent in the context of flue gas CO₂ capture.
- Field testing of a square cross section column design of the reactor was conducted at the NCCC using flue gas from a PC-fired power plant with a flow of 70 cfm (≈250 tons CO₂/year or 40-kWe); Results showed a capture efficiency of ≈65 percent and a CO₂ product gas purity above 90 percent.
- Completed 250 hours of testing on SRI's 40-kWe test unit at NCCC, with operational results providing insight to pilot plant design.
- Completed initial techno-economic assessment based on data from test unit operation. Initial TEA results indicate the advanced adsorption process increases the cost of electricity by approximately 46 percent, compared to the base case of no CO₂ capture, and results in a CO₂ capture cost of about \$45/tonne. Compared to the TEA benchmark case, the carbon microbead process offered several advantages: capital costs are reduced to 78 percent, fixed and variable O&M costs are reduced to 77 percent and 90 percent, respectively, and fuel costs are reduced to 81 percent.

next steps

- Complete design package for pilot plant.
- Fabricate and install pilot plant on-site at NCCC.
- Produce 1 ton of sorbent material for pilot scale commissioning and parametric testing.

available reports/technical papers/presentations

“Pilot-Scale Evaluation of an Advanced Carbon Sorbent-Based Process for Post-Combustion Carbon Capture,” Project Review Presentation, Pittsburgh, PA, October 2014. <http://www.netl.doe.gov/File%20Library/Research/Coal/carbon%20capture/post-combustion/FE0013123-Project-Review-Presentation-10-28-2014.pdf>

Krishnan, G. “Pilot-Scale Evaluation of an Advanced Carbon Sorbent-Based Process for Post-Combustion Carbon Capture,” presented at the 2014 NETL CO₂ Capture Technology Meeting, Pittsburgh, PA, July 2014. <http://www.netl.doe.gov/File%20Library/Events/2014/2014%20NETL%20CO2%20Capture/G-Krishnan-SRI-Pilot-Scale-Evaluation.pdf>

Krishnan, G., “Development of Novel Carbon Sorbents for CO₂ Capture,” Final Technical Report, March 2014. <http://www.osti.gov/scitech/servlets/purl/1132602>.

Krishnan, G. “Pilot-Scale Evaluation of an Advanced Carbon Sorbent-Based Process for Post-Combustion Carbon Capture”, presented at Project Kickoff Meeting, Pittsburgh, PA, December 2013. <http://www.netl.doe.gov/File%20Library/Research/Coal/ewr/co2/FE0013123-Kickoff-Presentation-12-04-2013.pdf>

Krishnan, G., “Development of Advanced Carbon Sorbents for CO₂ Capture,” presented at the 2013 NETL CO₂ Capture Technology Meeting, Pittsburgh, PA, July 2013. <http://www.netl.doe.gov/File%20Library/Events/2013/CO2%20Capture/G-Krishnan-SRI-Advanced-Carbon-Sorbents.pdf>.

Krishnan, G., “Development of Advanced Carbon Sorbents for CO₂ Capture,” presented at the 2012 NETL CO₂ Capture Technology Meeting, Pittsburgh, PA, July 2012. <http://www.netl.doe.gov/File%20Library/Research/Coal/ewr/CO2/development-of-advanced-carbon-sorbents-july2012.pdf>.

Hornbostel, M., “Development of Novel Carbon Sorbents for CO₂ Capture,” presented at the 2011 NETL CO₂ Capture Technology Meeting, Pittsburgh, PA, August 2011. <http://www.netl.doe.gov/File%20Library/research/coal/carbon%20capture/22Aug11-Hornbostel-SRI-Novel-Carbon-Sorbents.pdf>.

Krishnan, G., “Development of Novel Carbon Sorbents for CO₂ Capture,” presented at the 2010 NETL CO₂ Capture Technology Meeting, Pittsburgh, PA, September 2010. <http://www.netl.doe.gov/publications/proceedings/10/CO2capture/presentations/monday/Gopala%20Krishnan-NT0005578.pdf>.

Krishnan, G., “Development of Novel Carbon Sorbents for CO₂ Capture,” presented at the 9th Annual Conference on Carbon Capture and Sequestration, Pittsburgh, PA, May 2010.

Krishnan, G., “Development of Novel Carbon Sorbents for CO₂ Capture – Project Overview,” presented at the Annual NETL CO₂ Capture Technology for Existing Plants R&D Meeting, Pittsburgh, PA, March 2009. <http://www.netl.doe.gov/publications/proceedings/09/CO2/pdfs/5578%20SRI%20carbon%20sorbent%20%28Hornbostel%29%20mar09.pdf>.

SORBENT BASED POST-COMBUSTION CO₂ SLIPSTREAM TESTING

primary project goals

TDA Research is designing, constructing, and operating a slipstream 0.5-MWe pilot-scale process for post-combustion carbon dioxide (CO₂) capture using their low-cost alkalized alumina sorbent to conduct parametric and long-term, steady-state testing to demonstrate the effectiveness of the technology to reduce the cost of CO₂ capture and to develop scaleup conditions for the process.

technical goals

- Modify bench-scale CO₂ unit to mimic proposed pilot-plant configuration and conduct testing in bench unit to optimize process and collect data for pilot-plant design.
- Characterize breakthrough performance and pressure drop for different sorbent pellet sizes.
- Design pilot-plant unit based on developed low-cost alkalized alumina sorbent technology.
- Scaleup production of sorbent.
- Fabricate and install pilot-plant unit at the National Carbon Capture Center (NCCC).
- Parametric and steady-state testing on pilot plant using actual flue gas.
- Update EH&S study and techno-economic analysis based on pilot-plant testing results.

technical content

TDA Research is designing, constructing, and operating a slipstream 0.5-MWe pilot-scale process for post-combustion CO₂ capture. This technology is based on their novel sorbent developed previously in a Department of Energy (DOE)-funded project DE-NT0005497. TDA's CO₂ capture system uses a dry alkalized alumina sorbent. The regenerable sorbent acts as a physical adsorbent for CO₂. The CO₂ capture process runs near isothermally at around 140–160 °C in both adsorption and regeneration. No heating or cooling of the sorbent between absorption and regeneration steps is required. The sorbent is regenerated with low pressure (15.5 pounds per square inch absolute [psia]) steam. This regeneration is done at near the same temperature as adsorption. The sorbent shows excellent tolerance to contaminants, including SO₂ and NO_x. For this process, additional flue gas pretreatment upstream of the CO₂ capture unit may not be required beyond what is already in place with existing flue gas desulfurization (FGD) units.

An overall schematic of TDA's system is shown in Figure 1, consisting of two primary components: (1) the absorber/regenerator unit and (2) the CO₂ compression and purification unit. The process is designed for the sorbent to remove the CO₂ out of the flue gas at intermediate temperature and near ambient pressure, and then be regenerated with low-pressure superheated steam. Both the sorbent and the process are designed around that material.

technology maturity:

Pilot-Scale, Actual Flue Gas Slipstream (0.5 MWe)

project focus:

Alkalized Alumina Solid Sorbent

participant:

TDA Research, Inc.

project number:

FE0012870, NT0005497

NETL project manager:

Andrew O'Palko
andrew.opalko@netl.doe.gov

principal investigator:

Jeannine Elliott
TDA Research, Inc.
jelliott@tda.com

partners:

University of California at Irvine, Clariant, Babcock and Wilcox, Louisiana State University, Western Research Institute

performance period:

11/1/08 – 12/31/17

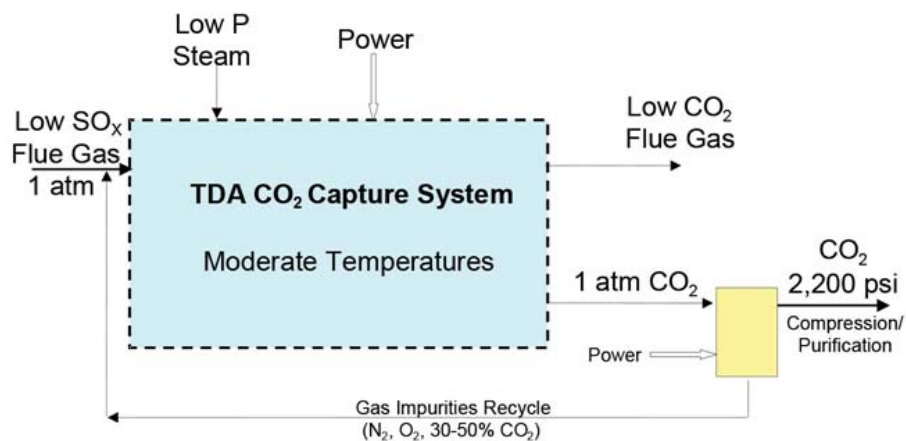

Figure 1: Schematic of TDA's CO₂ Capture System

The slipstream pilot plant is a 0.5-MWe skid mounted system to be installed at NCCC. The adsorber/regeneration system is made up of multiple fixed beds containing the alumina sorbent that switch between adsorption, regeneration, and purge operations. The complete slipstream pilot unit includes adsorber/regeneration beds, heat exchangers, and blowers.

Slipstream pilot-unit testing under both parametric and steady-state conditions using actual coal-fired flue gas provides data and recommended operating conditions to update the techno-economic analysis and EH&S assessment as well as for definition of recommended scale-up conditions. The project aims to demonstrate the novel system for reduction in carbon capture cost from coal-fired power plants.

The sorbent and process parameters identified to date are provided in Table 1.

TABLE 1: PROCESS PARAMETERS FOR TDA ALKALIZED ALUMINA SORBENT

	Units	Current R&D Value	Target R&D Value
Sorbent			
True Density at STP	kg/m ³	750	750
Bulk Density	kg/m ³	520	520
Average Particle Diameter	mm	1.3	3.175
Particle Void Fraction	m ³ /m ³	0.55	0.55
Packing Density	m ² /m ³	9.4E+07	9.4E+07
Solid Heat Capacity at STP	kJ/kg-K	0.72	0.72
Crush Strength	kgf	8	8
Manufacturing Cost for Sorbent	\$/kg	10	4.4
Adsorption			
Pressure	bar	1.12	1.12
Temperature	°C	150	140
Equilibrium Loading	g mol CO ₂ /kg	1.0	1.5
Heat of Absorption	kJ/mol CO ₂	-12.5 to -41.9	-12.5 to -41.9
Desorption			
Pressure	bar	1.17	1.17
Temperature	°C	160	150
Equilibrium Loading	mol/mol	0.93	1.0
Heat of Desorption	kJ/mol CO ₂	12.5 to 41.9	12.5 to 41.9

TABLE 1: PROCESS PARAMETERS FOR TDA ALKALIZED ALUMINA SORBENT

	Units	Current R&D Value	Target R&D Value
Proposed Module Design		<i>(for equipment developers)</i>	
Flow Arrangement/Operation	—	Multiple fixed bed	
Flue Gas Flowrate	kg/hr	2,273	
CO ₂ Recovery, Purity, and Pressure	%/%/bar	90/95/1.013 bar	
Adsorber Pressure Drop	bar	0.02	

Definitions:

STP – Standard Temperature and Pressure (15 °C, 1 atm).

Sorbent – Adsorbate-free (i.e., CO₂-free) and dry material as used in adsorption/desorption cycle.

Manufacturing Cost for Sorbent – “Current” is market price of material, if applicable; “Target” is estimated manufacturing cost for new materials, or the estimated cost of bulk manufacturing for existing materials.

Adsorption – The conditions of interest for adsorption are those that prevail at maximum sorbent loading, which typically occurs at the bottom of the adsorption column. These may be assumed to be 1 atm total flue-gas pressure (corresponding to a CO₂ partial pressure of 0.13 bar) and 40 °C; however, measured data at other conditions are preferable to estimated data.

Desorption – The conditions of interest for desorption are those that prevail at minimum sorbent loading, which typically occurs at the bottom of the desorption column. Operating pressure and temperature for the desorber/stripper are process-dependent. Measured data at other conditions are preferable to estimated data.

Pressure – The pressure of CO₂ in equilibrium with the sorbent. If the vapor phase is pure CO₂, this is the total pressure; if it is a mixture of gases, this is the partial pressure of CO₂. Note that for a typical PC power plant, the total pressure of the flue gas is about 1 atm and the concentration of CO₂ is about 13.2 percent. Therefore, the partial pressure of CO₂ is roughly 0.132 atm or 0.130 bar.

Packing Density – Ratio of the active sorbent area to the bulk sorbent volume.

Loading – The basis for CO₂ loadings is mass of dry, adsorbate-free sorbent.

Flow Arrangement/Operation – Gas-solid module designs include fixed, fluidized, and moving bed, which result in either continuous, cyclic, or semi-regenerative operation.

Other Parameter Descriptions:

Chemical/Physical Sorbent Mechanism – The sorbent is an adsorbent and is regenerated with steam.

Sorbent Contaminant Resistance – Based on extended cycling 1,500 hours with simulated flue gas with 13.8 percent CO₂, 104 parts per million (ppm) SO₂, 3 percent oxygen (O₂), and 9 percent H₂O, sorbent life was calculated to be 1 year with 5ppm of SO₂. No effect of NO_x on capacity was seen after 200 cycles with 739 ppm nitric oxide (NO) and 84 ppm nitrogen dioxide (NO₂).

Flue Gas Pretreatment Requirements – Flue gas should have <5 ppm SO_x.

Sorbent Makeup Requirements – 15 percent per year.

Process Design Concept – See Figure 1 above.

Proposed Module Design – Note the module location, as well as the pressure, temperature and composition of the gas entering the module. TDA’s CO₂ capture system is located downstream of the FGD unit. The adsorbent removes dilute CO₂ from the flue gas (10–14 percent CO₂, 8–10 percent H₂O, <5 ppm SO₂) at intermediate temperature (140 °C) and near ambient pressure.

technology advantages

- Inexpensive, durable sorbent.
- Low pressure (17 psi) steam for sorbent regeneration, low regeneration energy.
- Near isothermal operation.
- No heat recovery from solids required.
- Rapid adsorption/regeneration kinetics due to surface-only adsorption.
- Low heat of adsorption.
- Counter-current operation maximizes capture efficiency and sorbent loading.

R&D challenges

- Minimize the parasitic demands from the sorbent system.
- Effectively produce a sorbent from low-cost raw materials with extensive regenerative life.

results to date/accomplishments

- Demonstrated bench-scale unit at Western Research Institute on coal-derived flue gas.
- Completed lab-scale reactor testing.
- Completed design of the bench-scale unit.
- Performed TGA, BET, and crush strength analyses on a variety of sorbent materials.
- Determined alkalized alumina to be the optimum sorbent with a loading capacity of 0.7 wt%.
- Performed extended period testing up to 1,800 cycles and found the sorbent maintained its loading capacity at near-constant levels throughout.
- Optimized the sorbent composition and production process.
- Performed sorbent testing and characterization.
- Initiated 1,500-hour sorbent cycling test to evaluate the SO_x contamination of the sorbent and to complete wear and service assessments of the sorbent.
- Evaluated the effect of NO_x in simulated flue gas. No loss of CO₂ loading capacity observed after 180 cycles with 820 ppm of NO_x.
- Created a CO₂ capture process design and ASPEN model that includes steam source, CO₂ compression, and heat sources, and calculates efficiency.
- Evaluated improved sorbent material with 40 percent higher loading capacity.
- Process improvements included parallel flow in the adsorption beds rather than series to reduce pressure drop, and development of a recycle pattern to reduce steam usage. Results showed that 90 percent capture, with a lower pressure drop, could still be achieved.
- Sorbent pellets were produced in 1/20" to 1/8" diameter cylinders and quadrilobes. Kinetics of the various sized pellets were evaluated.
- Modified the 12-bed bench-scale test unit to mimic planned pilot-plant design.

next steps

- Testing on bench-scale unit to optimize process and to confirm design element choices for the pilot-scale unit.
- Detailed pilot-plant design and engineering.

available reports/technical papers/presentations

“Sorber Based Post-Combustion CO₂ Slipstream Testing,” presented by Jeannine Elliott, TDA Research, Inc., 2014 NETL CO₂ Capture Technology Meeting, Pittsburgh, PA, July 2014. [http://www.netl.doe.gov/File Library/Events/2014/2014 NETL CO₂ Capture/J-Elliott-TDA-Sorber-Based-Post-Combustion-CO₂-Slip-Stream.pdf](http://www.netl.doe.gov/File Library/Events/2014/2014 NETL CO2 Capture/J-Elliott-TDA-Sorber-Based-Post-Combustion-CO2-Slip-Stream.pdf).

“Sorber Based Post-Combustion CO₂ Slipstream Testing,” Project Kick-Off Meeting Presentation, Pittsburgh, PA, May 20, 2014. <http://www.netl.doe.gov/File Library/Research/Coal/carbon capture/post-combustion/FE0012870-Kickoff-Mtg-05-2014.pdf>.

Elliott, J.; and Copeland, R., “Low-Cost Solid Sorber for CO₂ Capture on Existing Coal-Fired Power Plants,” Final Report, November 15, 2013. <http://www.netl.doe.gov/File%20Library/Research/Coal/carbon%20capture/post-combustion/05497-Final-Report-083113.pdf>.

Elliott, J., and Srinivas, G., “Low-Cost Sorber for CO₂ Capture on Existing Plants,” presented at the 2012 NETL CO₂ Capture Technology Meeting, Pittsburgh, PA, July 2012.

Elliott, J., and Srinivas, G., “Post-Combustion CO₂ Capture with Alkalized Alumina,” presented at the 2011 NETL CO₂ Capture Technology Meeting, Pittsburgh, PA, August 2011.

<http://www.netl.doe.gov/publications/proceedings/09/CO2/pdfs/5497%20TDA%20sorber%20%28Elliott%29%20mar09.pdf>.

Elliott, J., Srinivas, G., and Copeland, R., “Low-Cost Sorber for Capturing CO₂ Emissions Generated by Existing Coal-Fired Power Plants,” presented at the 2010 NETL CO₂ Capture Technology Meeting, Pittsburgh, PA, September 2010.

<http://www.netl.doe.gov/publications/proceedings/10/cO2capture/presentations/monday/Jeanine%20Elliott-NT0005497.pdf>.

Elliott, J., Srinivas, G., and Copeland, R., “Low-Cost Solid Sorber for CO₂ Capture on Existing Coal-Fired Power Plants,” presented at the 26th Annual International Pittsburgh Coal Conference, Pittsburgh, PA, September 2009.

<http://www.tda.com/Library/docs/PCC%20Sept%202009%20v3.pdf>.

Elliott, J., and Srinivas, G., “Low-Cost Sorber for Capturing CO₂ Emissions Generated by Existing Coal-Fired Power Plants—Project Overview,” presented at the Annual NETL CO₂ Capture Technology for Existing Plants R&D Meeting, Pittsburgh, PA, March 2009.

BENCH-SCALE DEVELOPMENT AND TESTING OF AEROGEL SORBENTS FOR CO₂ CAPTURE

primary project goals

Aspen Aerogels is designing an innovative aerogel sorbent for carbon dioxide (CO₂) capture with improved CO₂ capacity, high adsorption/desorption cyclic stability, and resistance to contaminants in the flue gas to improve the performance and economics of CO₂ capture.

technical goals

- Optimize amine functional aerogel (AFA) for carbon adsorption to maximize CO₂ adsorption, decrease regeneration temperature, maintain kinetics for fluidized bed operation, and maintain high cyclic-adsorption stability.
- Develop optimum AFA pellet binder formulations.
- Develop aerogel production processes.
 - AFA powder pelletized by mixing with binder.
 - Direct formation of AFA beads.
- Develop a SO_x-resistant coating to minimize aerogel degradation due to flue gas contaminants.
- Test and evaluate aerogel sorbent technology at the bench scale to determine CO₂ capture performance and optimize operating conditions.
- Complete a techno-economic analysis of the system.

technical content

Aspen Aerogels is designing an aerogel sorbent (AFA) for CO₂ capture with improved CO₂ capacity, high adsorption/desorption cyclic stability, and resistance to contaminants in the flue gas to achieve an overall reduction in total carbon capture cost. The AFA contains amine groups bonded to the aerogel backbone. AFA benefits include high surface area/high porosity, hydrophobicity to enhance CO₂ adsorption selectivity, low specific heat for lower energy regeneration, and high temperature stability. The unique, specific aerogel structural morphology is shown in Figure 1, along with the AFA beads, shown in Figure 2.

technology maturity:

Bench-Scale, Simulated Flue Gas

project focus:

Advanced Aerogel Sorbents

participant:

Aspen Aerogels, Inc.

project number:

FE0013127

NETL project manager:

Isaac Aurelio
isaac.aurelio@netl.doe.gov

principal investigator:

Redouane Begag
Aspen Aerogels, Inc.
rbegag@aerogel.com

partners:

University of Akron,
ADA Environmental Solutions

performance period:

10/1/13 – 9/30/16

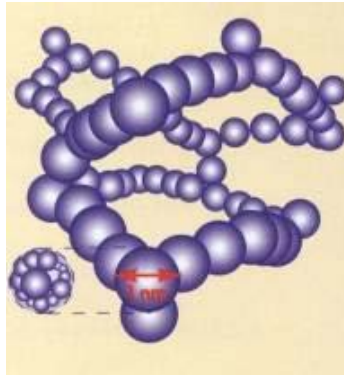

Figure 1: Structural Morphology of an Aerogel



Figure 2: Aerogel in Bead Form

The current project is aimed to maximize those benefits via bench-scale evaluation of the aerogel sorbents. Optimization of the initial sorbent formulations is aimed to increase CO₂ loading capacity, improve resistance to flue gas contaminants, maintain kinetics for fluidized bed operation, and maintain high cyclic stability. Initial testing on aerogel powders provides performance data to determine optimal formulations. For use in larger scale applications, the use of AFA pellets or beads is necessary instead of powders. The AFA pellets are formed by adding binder to the powder formulas. Therefore testing is also necessary on the fabricated AFA pellets. Finally, further process development is required to optimize the process of aerogel bead fabrication. Bead performance will be compared to AFA pellet performance, with not only the optimization of CO₂ capacity, cycle life, and stability to contaminants, but also for parameters important to high performance in a fluidized bed, including particle size, density, attrition index, and crush strength. Bench-scale cold-flow fluidized bed testing on the final AFA bead formulations provides hydrodynamic properties and heat transfer coefficients. The CO₂ system containing the adsorber unit and regenerator unit is shown in Figure 3.

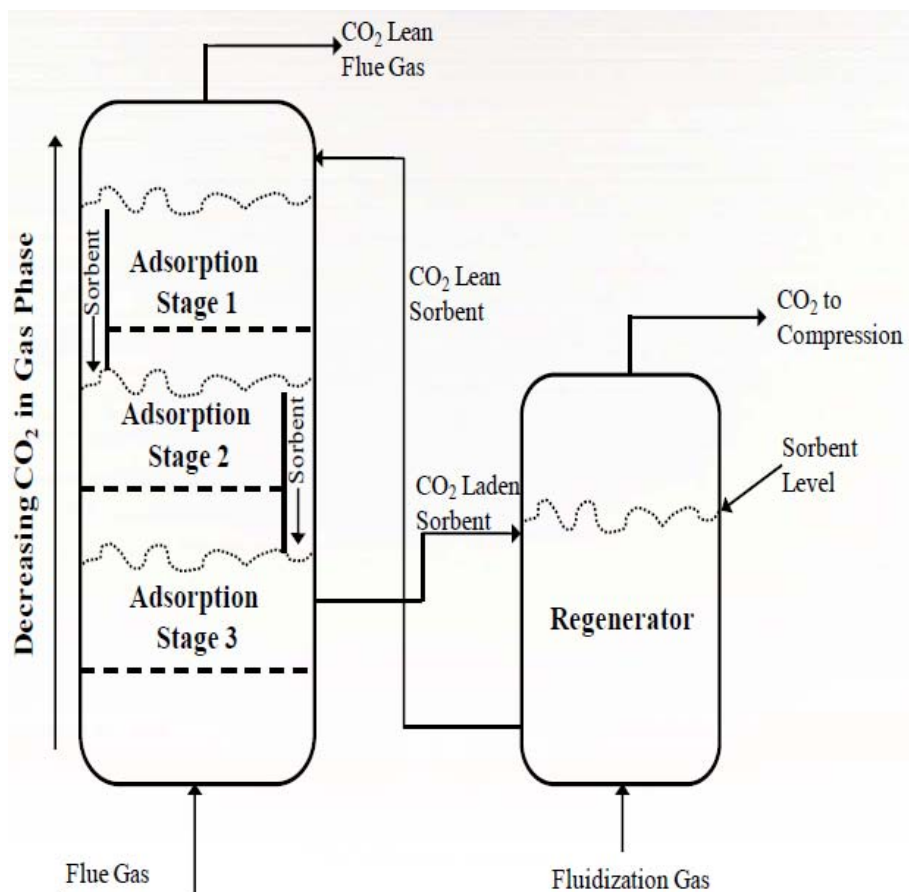

Figure 3: ADA-sorb™ Process

The sorbent and process parameters identified to date are provided in Table 1.

TABLE 1: ASPEN AEROGEL SORBENT PARAMETERS

	Units	Current R&D Value	Target R&D Value
Sorbent			
True Density at STP	kg/m ³	1,300	1,200–1,300
Bulk Density	kg/m ³	250–800	≈1,000
Average Particle Diameter	mm	0.2–1.0	0.3–0.6
Particle Void Fraction	m ³ /m ³	—	0.91–0.94
Packing Density	m ² /m ³	—	TBD
Solid Heat Capacity at STP	kJ/kg-K	≈1.3	<1
Crush Strength	kg _f	Not available yet	—
Manufacturing Cost for Sorbent	\$/kg	—	TBD
Adsorption			
Pressure	bar	0.8 (in Colorado)	1.0
Temperature	°C	40	<70
Equilibrium Loading	g CO ₂ /kg sorbent	100–200	>250
Heat of Adsorption	kJ/mol CO ₂	55–62	60

TABLE 1: ASPEN AEROGEL SORBENT PARAMETERS (CONTINUED)

	Units	Current R&D Value	Target R&D Value
Desorption			
Pressure	bar	0.8 (in Colorado)	1.0
Temperature	°C	100–120	<130
Equilibrium Loading*	g mol CO ₂ /kg	20–100	<100
Heat of Desorption	kJ/mol CO ₂	55–62	
Proposed Module Design		<i>(for equipment developers)</i>	
Flow Arrangement/Operation	—		
Flue Gas Flowrate	kg/hr		
CO ₂ Recovery, Purity, and Pressure	%/%/bar		
Adsorber Pressure Drop	bar		

*Under 100% CO₂

Definitions:

STP – Standard Temperature and Pressure (15 °C, 1 atm).

Sorbent – Adsorbate-free (i.e., CO₂-free) and dry material as used in adsorption/desorption cycle.

Manufacturing Cost for Sorbent – “Current” is market price of material, if applicable; “Target” is estimated manufacturing cost for new materials, or the estimated cost of bulk manufacturing for existing materials.

Adsorption – The conditions of interest for adsorption are those that prevail at maximum sorbent loading, which typically occurs at the bottom of the adsorption column. These may be assumed to be 1 atm total flue-gas pressure (corresponding to a CO₂ partial pressure of 0.13 bar) and 40 °C; however, measured data at other conditions are preferable to estimated data.

Desorption – The conditions of interest for desorption are those that prevail at minimum sorbent loading, which typically occurs at the bottom of the desorption column. Operating pressure and temperature for the desorber/stripper are process-dependent. Measured data at other conditions are preferable to estimated data.

Pressure – The pressure of CO₂ in equilibrium with the sorbent. If the vapor phase is pure CO₂, this is the total pressure; if it is a mixture of gases, this is the partial pressure of CO₂. Note that for a typical PC power plant, the total pressure of the flue gas is about 1 atm and the concentration of CO₂ is about 13.2 percent. Therefore, the partial pressure of CO₂ is roughly 0.132 atm or 0.130 bar.

Packing Density – Ratio of the active sorbent area to the bulk sorbent volume.

Loading – The basis for CO₂ loadings is mass of dry, adsorbate-free sorbent.

Flow Arrangement/Operation – Gas-solid module designs include fixed, fluidized, and moving bed, which result in either continuous, cyclic, or semi-regenerative operation.

Other Parameter Descriptions:

Chemical/Physical Sorbent Mechanism – The primary mechanism of CO₂ capture on AFA sorbents occurs by chemisorption. The homogenous distribution of amine grafted on the high surface area aerogel structure facilitates mass transfer of CO₂ to and from receptor sites. Adsorption/desorption of CO₂ occurs by temperature swing, between 40 °C and 100–120 °C.

Sorbent Contaminant Resistance – Development of a series SO₂ resistant coatings has been initiated. Preliminary studies of the performance of the coatings were carried out. These coatings reduced the effect of SO₂ poisoning on the AFA sorbent and increased the stability of the sorbent in the presence of SO₂. The effectiveness of the newly developed coatings shows a CO₂ capacity reduction of only 4 percent after 22 cycles versus 55–61 percent reduction with no coating on the sorbent.

Sorbent Attrition and Thermal/Hydrothermal Stability – Selected AFA pellets were subjected to ASTM D5757 (Standard Test Method for Determination of Attrition and Abrasion of Powdered Catalysts by Air Jets), to measure the attrition indices. The initial sizes of the tested pellets are above 500 μm . The mass percentages of the attrited components were weighed after 3 hours of attrition testing. The binder used to make the AFA pellets resulted in pellets with <2 percent attrition.

Flue Gas Pretreatment Requirements – Any flue gas pretreatment requirements depend on the sorbent tolerance to SO_2 . Success in the development of an SO_2 resistant coating will determine if a SO_2 polishing scrubber will be needed prior to the CO_2 capture process, based on the maximum SO_2 concentration that the sorbent can tolerate.

As for temperature of the flue gas entering the adsorber, for example for an adsorption temperature of 40 $^\circ\text{C}$, it is likely that some cooling will be required due to inevitable gas heating in the blower (to overcome the pressure drop of the sorbent bed in the adsorber).

Sorbent Makeup Requirements – This has not yet been determined.

Waste Streams Generated – None known.

Process Design Concept – See Figure 3.

technology advantages

- AFA sorbent has high CO_2 capacity and long life, reducing equipment size requirements and process costs.
- High sorbent selectivity allows for reduced sorbent cycling times, which allows for reductions in sorbent quantity, reactor size, and cost.
- Reduced delta T for adsorption/desorption.

R&D challenges

- Optimize pellet formulation to balance properties for optimum performance, including CO_2 capacity, attrition and SO_x resistance, thermal conductivity to improve kinetics, as well as selecting the optimal particle size and density for use in a fluidized bed.
- Optimize bead fabrication to match performance of the aerogel powder.
- Overcome the problem of reduced CO_2 capacity for AFA beads due to some amine leaching out during the fabrication process.

results to date/accomplishments

- Initial aerogel formulations were optimized. Aerogel sorbent Type #1 was identified with high CO_2 total capacity (≈ 20 percent) and working capacity (≈ 8 percent), with stability up to 250 adsorption/desorption cycles. Formulation has higher moisture uptake than the 1 percent desired.
- Optimized aerogels with reduced delta T for adsorption/desorption.
- Optimized pellet fabrication, retaining over 85 percent of the CO_2 capture capacity of the powder and minimizing attrition (less than 2 percent loss).
- SO_2 resistant coatings (SRE series) developed and tested on AFA powders.
- Double functionalized aerogel (aerogel sorbent Type #2) improved CO_2 capacity by more than 15 percent over aerogel sorbent Type #1, however an inert additive must be added to enhance thermal stability and kinetics.

next steps

- Optimize spherical bead fabrication process to maintain high CO_2 capacity, minimize amine loss during fabrication, and improve heat transfer and mechanical strength.
- Determine pellet and bead sorbent performance through repeated adsorption/desorption cycles with simulated flue gas.

available reports/technical papers/presentations

“Bench-Scale Development and Testing of Aerogel Sorbents,” Presented by George Gould, Aspen Aerogels, Inc., 2014 NETL CO₂ Capture Technology Meeting, Pittsburgh, PA, July 2014. [http://www.netl.doe.gov/File Library/Events/2014/2014 NETL CO₂ Capture/G-Gould-AAI-Bench-Scale-Development.pdf](http://www.netl.doe.gov/File Library/Events/2014/2014 NETL CO2 Capture/G-Gould-AAI-Bench-Scale-Development.pdf).

BP1 Review Meeting Presentation, July 2014. <http://www.netl.doe.gov/File Library/Research/Coal/carbon capture/post-combustion/BP1-NETL-presentation-Final-Rev-2-nonproprietary.pdf>.

“Bench-Scale Development and Testing of Aerogel Sorbent for CO₂ Capture,” Project Kick-Off Meeting Presentation, Pittsburgh, PA, November 8, 2013. <http://www.netl.doe.gov/File Library/Research/Coal/ewr/CO2/Aspen-Aerogels-NETL-DOE--Kick-Off-Final-Non-proprietary.pdf>.

BENCH-SCALE DEVELOPMENT AND TESTING OF RAPID PRESSURE SWING ABSORPTION FOR CARBON DIOXIDE CAPTURE

primary project goals

WR Grace and the University of South Carolina are developing a rapid pressure swing adsorption (PSA) process to evaluate concept cost and performance benefits by testing a bench-scale system using a low-cost, structured adsorbent with low-pressure drop, high mass-transfer rates, high capacity, and high availability that will enable large feed throughputs.

technical goals

- Develop an attrition-resistant and low-pressure drop structured adsorbent based on a commercial zeolite that is compatible with the high velocities associated with rapid PSA operation.
- Develop a rapid PSA cycle configuration in concert with the structured adsorbent so that the resulting rapid PSA process delivers an exceptional performance at reduced capital and operating costs.

technical content

PSA is attractive because it only requires electricity and not any of the power plant's steam. A PSA cycle has recently been developed for carbon dioxide (CO₂) capture that has a total separation energy of 25 kJ/mol compared to 39.0 kJ/mol for a monoethanolamine (MEA) system. This new PSA cycle achieves more than 90 percent CO₂ recovery and more than 95 vol% CO₂ purity using commercial zeolite pellets. Although it could be retrofitted to a coal-fired power plant today, the columns would be exceedingly large and thus capital-intensive. A rapid PSA process, taking advantage of a much shorter cycle time, could potentially solve this problem by reducing the cycle time from 300 seconds (conventional PSA cycle) to 30 seconds or less. This would increase the feed throughput, and thus decrease the size of the columns by a factor of 10 or more, significantly reducing both the capital and operating costs, as well as the plant footprint.

The key challenge to the success of this concept is two-fold: (1) an attrition-resistant and low-pressure drop structured adsorbent must be developed based on commercial zeolite that is compatible with the high velocities associated with rapid PSA operation; and (2) a rapid PSA cycle configuration must be developed in concert with the structured adsorbent so that the resulting rapid PSA process achieves necessary cost and performance metrics.

One advantage of a rapid PSA process over other CO₂ adsorption processes is simplified heat management. The rapid cycle times minimize temperature swings. Thus, the columns will heat up only slightly during adsorption and cool down only slightly during desorption, approaching nearly isothermal operation, which is optimal.

technology maturity:

Bench-Scale, Simulated
Flue Gas

project focus:

Rapid Pressure Swing
Adsorption

participant:

WR Grace

project number:

FE0007639

NETL project manager:

Bruce Lani
bruce.lani@netl.doe.gov

principal investigator:

James A. Ritter
University of South
Carolina
ritter@cec.sc.edu

partners:

University of South
Carolina,
Catacel Corporation,
Battelle Memorial Institute

performance period:

5/1/12 – 7/31/16

Management of water will provide some operational challenges. Degradation of the PSA process performance in the presence of water is well documented. It is anticipated that for a rapid PSA CO₂ removal process, up to 95 percent of the water in the flue gas will need to be removed using commercial desiccant technology. This will increase capital and operating costs; however, any increases are more than offset by cost savings in other parts of the process.

The structured adsorbent to be developed will consist of zeolite crystals coated on a metal support. This process has been successfully demonstrated using metal foil, as shown in Figure 1.

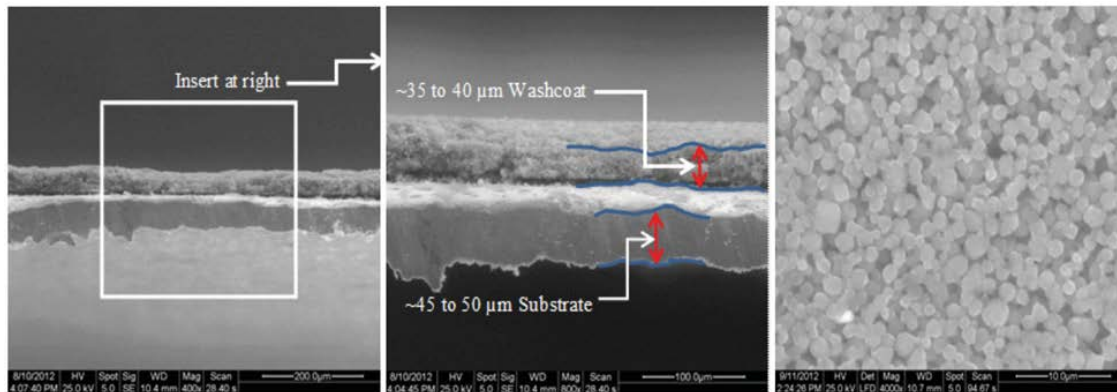

Figure 1: Edge View of Zeolite-Coated Metal Substrate at 400x Magnification (left); Edge View of Zeolite-Coated Metal Substrate at 800x Magnification Indicating Washcoat is 35–40 μm Thick (center); Top View of Zeolite-Coated Metal Foil Substrate at 4,000x Magnification (right)

Corrugated cores have been fabricated (Figure 2) to serve as the metal substrate for testing the rapid PSA process. These cores were tested to evaluate pressure drop, and coated with zeolite crystals for process testing.



Figure 2: Side View of 1.5" x 6" x 289 cpsi Corrugated Cores

In addition, a dynamic volumetric frequency response (DVFR) apparatus (Figure 3) that is being used to characterize adsorbate mass-transfer rates in various adsorbents at cycle times up to 10 Hz, as well as a single-column rapid pressure swing adsorption (S-C rPSA) system (Figure 4), is being used to study the effect of cycle time on the mass-transfer rates at step times as short as 0.25 seconds.



Figure 3: Photograph of Dynamic Volumetric Frequency Response (DVFR) Apparatus

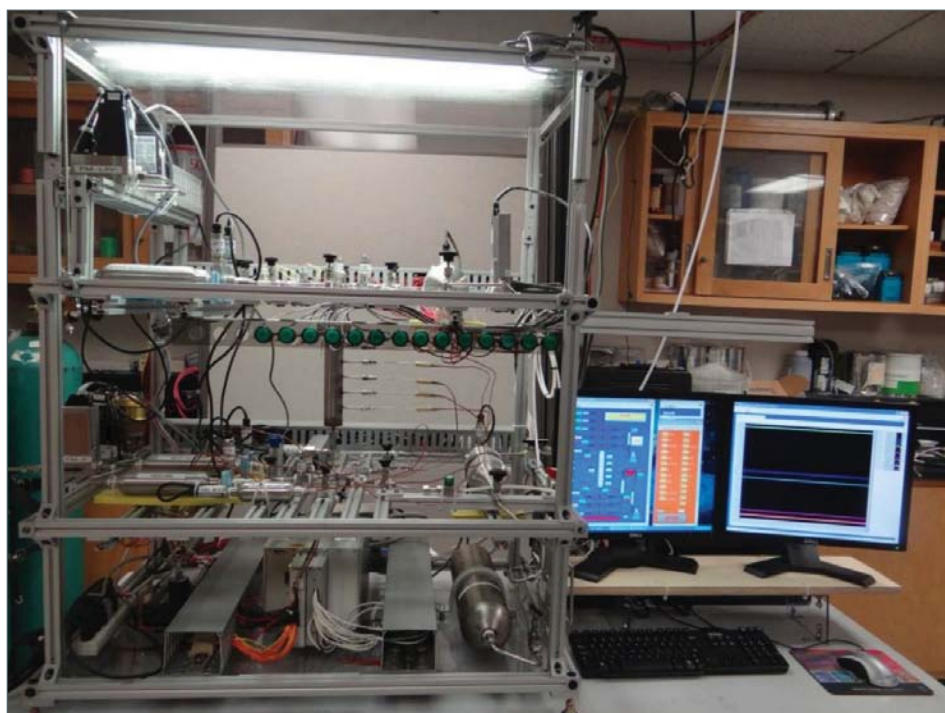

Figure 4: Photograph of S-C rPSA System

TABLE 1: ADSORPTION-BASED POST-COMBUSTION CO₂/N₂ SEPARATIONS¹

	Units	Current R&D Value	Target R&D Value
Sorbent			
True Density at STP ²	kg/m ³	1,090	2,518
Bulk Density ³	kg/m ³	688	400
Average Particle Diameter ⁴	mm	5.0	0.100
Particle Void Fraction	m ³ /m ³	0.47	0.47
Packing Density	m ² /m ³	750	6,070
Solid Heat Capacity at STP ²	kJ/kg-K	0.92	0.82
Crush Strength ⁵	kgf	3.6	N/A
Manufacturing Cost for Sorbent	\$/kg	20	37.4
Absorption⁶			
Pressure ⁷	bar	1.2/1.14	1.2/1.14
Temperature	°C	50	50
Equilibrium Loading ⁸	g mol CO ₂ /kg	4.18	4.18
Average Bed Loading at End of HR step	g mol CO ₂ /kg	2.46*	2.50
Heat of Absorption	kJ/mol CO ₂	37.5–46.0	37.5–46.0
Desorption			
Pressure ⁷	bar	0.05/0.00085	0.05/0.00085
Temperature	°C	50	50
Equilibrium Loading ⁹	g mol CO ₂ /kg	0.14	0.14
Average Bed Loading at End of LR step	g mol CO ₂ /kg	1.20*	1.20
Heat of Desorption	kJ/mol CO ₂	37.5–46.0	37.5–46.0
Proposed Module Design		<i>(for equipment developers)</i>	
Flow Arrangement/Operation	—	fixed bed/cyclic	fixed bed/cyclic
Flue Gas Flowrate	kg/hr	2.32 × 10 ⁶	2.32 × 10 ⁶
CO ₂ Recovery, Purity, and Pressure	%/%/bar	90%, 95%, 1.38 bar	
Adsorber Pressure Drop	bar	0.15	0.15
<p>1. For the Current R&D Value, the calculation is based on 5-mm 13X beads. For the Target R&D Value, the calculation is based on a 52-micron thick stainless steel support containing a 100-micron thick zeolite crystal coating at each side.</p> <p>2. The Target R&D Value includes the stainless steel support.</p> <p>3. The Target R&D Value corresponds to mass of adsorbent (zeolite) per volume of bed.</p> <p>4. The Target R&D Value corresponds to coating thickness.</p> <p>5. The structured support for the target will be unaffected by PSA dynamic stresses.</p> <p>6. The adsorption step is considered as the Heavy Reflux step, which follows the feed step in the PSA cycle and is highly enriched in CO₂ and obtained from another desorption step in the PSA cycle.</p> <p>7. First value is total pressure; second value is partial pressure of CO₂.</p> <p>8. The value corresponds to conditions of the heavy product gas.</p> <p>9. The value corresponds to conditions of the light product gas.</p>			

Definitions:

STP – Standard Temperature and Pressure (15 °C, 1 atm).

Sorbent – Adsorbate-free (i.e., CO₂-free) and dry material as used in adsorption/desorption cycle.

Manufacturing Cost for Sorbent – “Current” is market price of material, if applicable; “Target” is estimated manufacturing cost for new materials, or the estimated cost of bulk manufacturing for existing materials.

Adsorption – The conditions of interest for adsorption are those that prevail at maximum sorbent loading, which typically occurs at the bottom of the adsorption column. These may be assumed to be 1 atm total flue-gas pressure (corresponding to a CO₂ partial pressure of 0.13 bar) and 40 °C; however, measured data at other conditions are preferable to estimated data.

Desorption – The conditions of interest for desorption are those that prevail at minimum sorbent loading, which typically occurs at the bottom of the desorption column. Operating pressure and temperature for the desorber/stripper are process-dependent. Measured data at other conditions are preferable to estimated data.

Pressure – The pressure of CO₂ in equilibrium with the sorbent. If the vapor phase is pure CO₂, this is the total pressure; if it is a mixture of gases, this is the partial pressure of CO₂. Note that for a typical pulverized coal (PC) power plant, the total pressure of the flue gas is about 1 atm and the concentration of CO₂ is about 13.2 percent. Therefore, the partial pressure of CO₂ is roughly 0.132 atm or 0.130 bar.

Packing Density – Ratio of the active sorbent area to the bulk sorbent volume.

Loading – The basis for CO₂ loadings is mass of dry, adsorbate-free sorbent.

Flow Arrangement/Operation – Gas-solid module designs include fixed, fluidized, and moving bed, which result in either continuous, cyclic, or semi-regenerative operation.

Other Parameter Descriptions:

Chemical/Physical Sorbent Mechanism – The relative thermodynamic adsorption selectivity towards CO₂ over other gases such as nitrogen (N₂), oxygen (O₂), and argon (Ar) on a commercial zeolite at partial pressures of CO₂ at around or below 1.0 bar.

Sorbent Contaminant Resistance – The effect of the contaminant sulfur dioxide (SO₂) is not clear yet; tests are planned. It is expected, however, that the 42 parts per million (ppm) in the fresh flue gas will be significantly reduced at the condensing heat exchanger that will be located upstream of the PSA unit. It is not expected that the zeolite will be irreversibly affected by nitrogen oxides (NO_x).

Sorbent Attrition and Thermal/Hydrothermal Stability – The sorbent will be deposited on the surface of a metal structured support; thus, thermal or mechanical stresses present in pelletized/beaded systems will not be observed.

Flue Gas Pretreatment Requirements – The flue gas requires a blower to bring the pressure up to 120 kPa and then a condensing heat exchanger followed by a dryer to bring the content of water to less than 0.1 vol% prior to entering the PSA unit.

Sorbent Makeup Requirements – There are no sorbent makeup requirements in PSA units. The structured adsorbent is expected to last at least 5 years and possibly 10 years before it needs to be replaced. This is common in commercial PSA systems.

Waste Streams Generated – There are no waste streams generated in the flowsheet. All potential waste streams are recycled and used in the process somewhere. For example, the condensing heat exchanger will produce about 460,000 lb/h of condensed water that is recycled back as makeup water for the flue gas desulfurization (FGD) unit. It may contain up to 1,125 mg/L of dissolved SO₂ and no other contaminants. In addition, about 3.69 x 10⁶ lb/h of N₂-rich product at about 80 °C is vented into the air. This stream will contain, by volume, about 1.8 percent CO₂, 4.0 percent H₂O, 3.3 percent O₂, 1.09 percent Ar, and balance N₂.

Proposed Module Design – Note the module location, as well as the pressure, temperature, and composition of the gas entering the module. The table below shows all the stream compositions and conditions throughout the proprietary process flowsheet. Column 7 (i.e., stream 7) is the feed to the PSA unit, which comes after the FGD unit and the water removal units described above. In addition, it is expected that stream 7 will have less than 2 parts per million by volume (ppmv) of sulfur oxides (SO_x) and about 92 ppmv of NO_x.

TABLE 2: STREAM COMPOSITIONS AND CONDITIONS IN EACH OF THE STREAMS (# COLUMNS) IN THE PROPRIETARY PROCESS FLOWSHEET

	1	2	3	4	5	6	7	8	9	10
V-L Mass Fraction										
CO ₂	20.28%	20.28%	0.00%	22.28%			22.56%	2.60%	2.60%	2.81%
H ₂ O	10.87%	10.87%	100.00%	2.09%	100.00%	100.00%	0.06%	0.00%	0.00%	2.57%
N ₂	65.11%	65.11%	0.00%	71.52%			73.17%	92.06%	92.06%	89.44%
O ₂	2.62%	2.62%	0.00%	2.88%			2.95%	3.74%	3.74%	3.63%
Ar	1.12%	1.12%	0.00%	1.23%			1.26%	1.60%	1.60%	1.55%
V-L Mole Fraction										
CO ₂	13.17%	13.17%	0.00%	15.36%			15.77%	1.69%	1.69%	1.80%
H ₂ O	17.25%	17.25%	100.00%	3.52%	100.00%	100.00%	0.10%	0.00%	0.00%	4.01%
N ₂	66.44%	66.44%	0.00%	77.46%			80.34%	93.83%	93.83%	89.90%
O ₂	2.34%	2.34%	0.00%	2.73%			2.83%	3.34%	3.34%	3.20%
Ar	80.00%	80.00%	0.00%	93.00%			0.97%	1.14%	1.14%	1.09%
V-L Mole Fraction (Dry Basis)										
CO ₂	15.92%	15.92%	0.00%	15.92%			15.78%	1.69%	1.69%	1.87%
N ₂	80.29%	80.29%	0.00%	80.29%			80.42%	93.83%	93.83%	93.66%
O ₂	2.83%	2.83%	0.00%	2.83%			2.83%	3.34%	3.34%	3.33%
Ar	97.00%	97.00%	0.00%	97.00%			0.97%	1.14%	1.14%	1.14%
V-L Flowrate (10 ³ lb/hr)	5.12	5.12	0.46	4.66	29.38	29.38	4.55	3.59	3.59	3.69
V-L Flowrate (10 ³ lb mol/hr)	17.91	17.91	2.55	15.36	163.22	163.22	14.82	12.57	12.57	13.11
V-L Flowrate (10 ³ SLPM)	3,039.38	3,039.38	432.62	2,607.36	27,698.57	27,698.57	2,514.09	2,132.28	2,132.28	2,225.55
Temperature (°F)	135.00	135.00	86.00	86.00	60.00	80.00	122.00	122.00	219.36	175.60
Pressure (psia)	14.70	14.70	14.70	17.38	20.00	19.00	17.24	15.06	14.86	14.72
	11	12	13	14	15	16	17	18	19	
V-L Mass Fraction										
CO ₂	96.49%	96.49%	96.49%	96.49%					96.74%	
H ₂ O	0.28%	0.28%	0.28%	0.28%	100.00%	100.00%	100.00%	100.00%	2.00%	
N ₂	3.23%	3.23%	3.23%	3.23%					3.24%	
O ₂	0.00%	0.00%	0.00%	0.00%					0.00%	
Ar	0.00%	0.00%	0.00%	0.00%					0.00%	
V-L Mole Fraction										
CO ₂	94.37%	94.37%	94.37%	94.37%					94.95%	
H ₂ O	66.00%	66.00%	66.00%	66.00%	100.00%	100.00%	100.00%	100.00%	5.00%	
N ₂	4.97%	4.97%	4.97%	4.97%					5.00%	
O ₂	0.00%	0.00%	0.00%	0.00%					0.00%	
Ar	0.00%	0.00%	0.00%	0.00%					0.00%	
V-L Mole Fraction (Dry Basis)										
CO ₂	95.00%	95.00%	95.00%	95.00%					95.00%	
N ₂	5.00%	5.00%	5.00%	5.00%					5.00%	
O ₂	0.00%	0.00%	0.00%	0.00%					0.00%	
Ar	0.00%	0.00%	0.00%	0.00%					0.00%	
V-L Flowrate (10 ³ lb/hr)	1.28	1.28	0.97	0.31	7.18	7.18	0.87	0.87	0.97	
V-L Flowrate (10 ³ lb mol/hr)	2.97	2.97	2.25	0.72	55.66	39.91	4.85	4.85	2.24	
V-L Flowrate (10 ³ SLPM)	504.34	504.34	381.81	122.53	9,445.33	6,772.09	823.84	823.84	379.48	
Temperature (°F)	122.00	122.00	122.00	122.00	60.00	80.00	60.00	80.00	104.00	
Pressure (psia)	1.20	20.00	20.00	20.00	20.00	19.00	20.00	19.00	2,215.00	

technology advantages

- Established large-scale technology for other applications.
- Needs no steam or water, only electricity.
- Tolerant to trace contaminants; possibly with use of guard or layered beds.
- Zeolite adsorbent commercial and widely available.
- Increase in cost of electricity (COE) lower than other capture technologies.
- If research and development (R&D) is successful, beds can be installed under a parking lot.

R&D challenges

- Energy-intensive, but better than current amines.
- Large beds required; implies large pressure drop, using more power.
- Large footprint.
- High capital cost.

results to date/accomplishments

- The PSA cycle was developed via process simulation that indicates a total separation energy of 24.6 kJ/mol (18.5 kJ/mol CO₂ removed for the PSA unit) and requires a small footprint (approximately 15 percent of a football field).
- A metal foil was successfully coated with commercial zeolite crystals, with the coating comprising approximately 85 percent zeolite and 15 percent inorganic binder, and having a nominal loading of 141 mg/in².
- Several commercial zeolite crystals have been screened for CO₂ working capacity (using thermo gravimetric analysis [TGA]), and some candidate materials have been identified.
- A volumetric frequency response system was constructed to measure mass-transfer rates in various commercial adsorbents up to 10 Hz.
- Demonstrated a limit of <20 kPa/m pressure drop through 400 cells per square inch core at very high velocities up to 25 m/s.
- A computational fluid dynamics (CFD) model for a geometry characteristic of a typical structured sorbent material has been developed and is being refined.
- The PSA cycle was refined using process simulation and continuously measured thermodynamic/mass-transfer data to reduce energy consumption.
- Adsorbent materials were characterized for optimum CO₂ loading and mass-transfer.
- The S-C rPSA was tested to study the role of cycle time on the mass-transfer rates.
- Developed new coating and rolling methods and produced structured adsorbent for zeolite-coated core structures.

next steps

- Two, S-C rPSA bench-scale systems are in operation and will continue to be tested.
- Technical and economic feasibility study to be further developed and refined.

available reports/technical papers/presentations

Ritter, James A., “Bench-Scale Development and Testing of Rapid PSA for CO₂ Capture,” presented at the 2014 NETL CO₂ Capture Technology Meeting, Pittsburgh, PA, July 2014, <http://www.netl.doe.gov/File%20Library/Events/2014/2014%20NETL%20CO2%20Capture/J-Ritter-USCarolina-Rapid-Pressure-Swing-Adsorption.pdf>.

Ritter, James A., “Bench-Scale Development and Testing of Rapid PSA for CO₂ Capture,” presented at the 2013 NETL CO₂ Capture Technology Meeting, Pittsburgh, PA, July 2013. <http://www.netl.doe.gov/File%20Library/Events/2013/CO2%20Capture/J-Ritter-USC-Rapid-Pressure-Swing-Adsorption.pdf>.

Ritter, James A., “Bench-Scale Development and Testing of Rapid PSA for CO₂ Capture,” presented at the 2012 NETL CO₂ Capture Technology Meeting, Pittsburgh, PA, July 2012.

BENCH-SCALE DEVELOPMENT OF AN ADVANCED SOLID SORBENT-BASED CO₂ CAPTURE PROCESS FOR COAL-FIRED POWER PLANTS

primary project goals

The goal of this project is to address the technical and economic hurdles to developing a sorbent-based carbon dioxide (CO₂) capture process by transitioning a promising sorbent chemistry, based on molecular basket sorbent (MBS) materials, to a low-cost sorbent suitable for use in a fluidized-bed process and developing a scalable circulating fluidized, moving-bed reactor (FMBR) process arrangement.

technical goals

- Improve the thermal and chemical stability of the base polyethyleneimine (PEI) reactant while transitioning the current fixed-bed form MBS material into a fluidizable form.
- Collect critical process engineering data using bench-scale testing equipment to allow for a detailed design of a CO₂ capture prototype system based on improved MBS materials.
- Improve reactor design, optimize operability, and optimize heat integration strategies for the FMBR system.
- Scaleup advanced MBS materials to roughly 1,000 lbs production for use in the CO₂ capture prototype system.
- Demonstrate the technical and economic feasibility of a commercial embodiment of the MBS-based CO₂ capture process through a detailed technology feasibility study.

technical content

The project team is developing an advanced sorbent process that utilizes a polymeric amine-based CO₂ sorbent developed by Pennsylvania State University (PSU) under a previous project (DE-FE-0000458) to capture CO₂ from coal-fired power plant flue gas. The solid sorbent consists of a high-surface area support, such as silica, impregnated with branched PEI polymer, as exhibited in Figure 1.

technology maturity:

Laboratory-Scale,
Simulated Flue Gas

project focus:

Advanced Solid Sorbents
and Processes for CO₂
Capture

participant:

RTI International

project number:

FE0007707

NETL project manager:

Bruce Lani
bruce.lani@netl.doe.gov

principal investigator:

Thomas Nelson
RTI International
tnelson@rti.org

partners:

Pennsylvania State
University,
Masdar New Ventures,
Masdar Institute,
Clariant,
Foster Wheeler
Corporation

performance period:

10/1/11 – 12/31/15

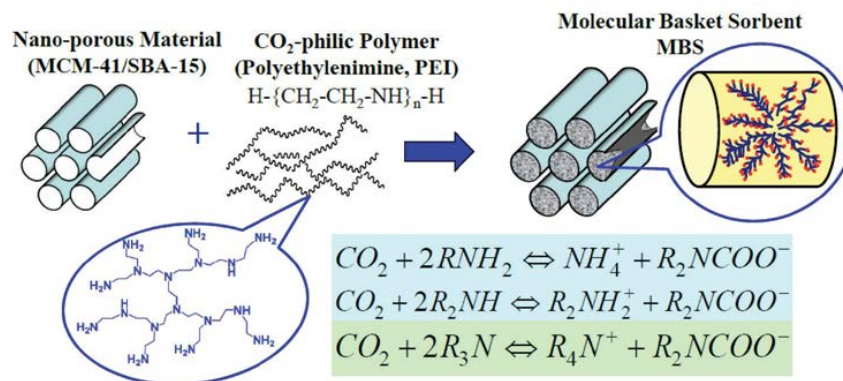

Figure 1: Molecular Basket Sorbent Concept

The branched polymer contains primary, secondary, and tertiary amine sites that absorb CO₂. Carbon dioxide adsorption is favored between 50 and 90 °C (122 and 194 °F), with a heat of reaction of $\Delta H_{abs} = 66 \text{ kJ/mol CO}_2$ (645 Btu/lb CO₂). At temperatures greater than 110 °C (230 °F), the reverse reactions predominate and the sorbent releases CO₂.

This advanced sorbent CO₂ capture process operates as a cyclic absorption-regeneration thermal swing process where the solid sorbent is continuously circulated between two FMBRs—a CO₂ absorber and a sorbent regenerator. A basic block flow diagram of this process, installed within a pulverized coal (PC)-fired power plant, is provided in Figure 2.

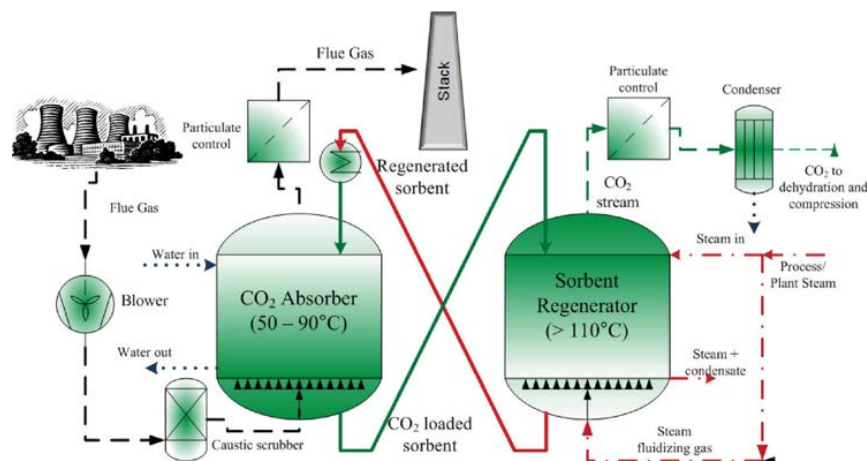

Figure 2: Block Flow Diagram of Advanced Solid Sorbent CO₂ Capture Process

Carbon dioxide-rich flue gas from the PC power plant goes through a caustic scrubbing system to remove strong acid gases prior to entering the CO₂ absorber. The CO₂ absorber is designed as an FMBR. Within the absorber, flue gas comes in contact with lean sorbent that is fed to the absorber from the sorbent regenerator. The sorbent selectively removes CO₂ and generates heat due to the heat of reaction for CO₂ removal. In order to control the sorbent bed temperature, cooling water is used to cool the sorbent through indirect contact. Treated flue gas exits the CO₂ absorber and enters a baghouse filter for removal of particulates, primarily attrited sorbent particles. Following particulate removal, the flue gas is then directed to the stack and vented.

The CO₂-rich sorbent exits the absorber and is transported to the sorbent regenerator. The sorbent regenerator design and operation is similar to the CO₂ absorber, except that the sorbent bed is indirectly heated with condensing steam in order to strip the sorbent of the absorbed CO₂. The regenerated sorbent produces a concentrated CO₂ gas stream that is swept out of the sorbent regenerator with a CO₂ sweep gas. The concentrated CO₂ gas stream is then sent to a dehydration and compression unit, and the sorbent is transferred through a sorbent cooling unit and on to the CO₂ absorber for continued CO₂ removal. Fresh sorbent is added to this stream to make up for attrited sorbent and diminished sorbent performance.

RTI will lead an effort to conduct process evaluations in a bench-scale, single-stage, fluidized-bed unit capable of sustained CO₂ capture and sorbent regeneration. A bench-scale, continuous-flow CO₂ capture prototype system will then be designed and fabricated. This system will be integrated and commissioned at the University of North Carolina at Chapel Hill's (UNCH-CH) coal-fired power plant, where extensive parametric and long-term flue gas testing will be performed.

TABLE 1: ADSORPTION-BASED POST-COMBUSTION CO₂/N₂ SEPARATIONS

	Units	Current R&D Value	Target R&D Value
Sorbent			
True Density at STP	kg/m ³	N/A	N/A
Bulk Density	kg/m ³	≈500	≈1,000
Average Particle Diameter	mm	≈0.1	0.05 to 0.2
Particle Void Fraction	m ³ /m ³	not measured	TBD
Packing Density	m ² /m ³	not measured	TBD
Solid Heat Capacity at STP	kJ/kg-K	1.53	1.1 to 1.5 (1.2)
Crush Strength	kg _f	N/A	N/A
Manufacturing Cost for Sorbent	\$/kg	N/A	<\$10/kg
Absorption			
Pressure	bar	1.01	1.01
Temperature	°C	75	60 to 90
Equilibrium CO ₂ Loading	g mol CO ₂ /kg	2.27	3.18
Heat of Absorption	kJ/mol CO ₂	66	60 to 70
Desorption			
Pressure	bar	1.01	1.01
Temperature	°C	100	>110
Equilibrium CO ₂ Loading	mol/mol	0.68	0.45
Heat of Desorption	kJ/mol CO ₂	78	70 to 80
Proposed Module Design		<i>(for equipment developers)</i>	
Flow Arrangement/Operation	—	—	
Flue Gas Flowrate	kg/hr	—	
CO ₂ Recovery, Purity, and Pressure	%/%/bar	—	
Adsorber Pressure Drop	bar	—	

Definitions:

STP – Standard Temperature and Pressure (15 °C, 1 atm).

Sorbent – Adsorbate-free (i.e., CO₂-free) and dry material as used in adsorption/desorption cycle.

Manufacturing Cost for Sorbent – “Current” is market price of material, if applicable; “Target” is estimated manufacturing cost for new materials, or the estimated cost of bulk manufacturing for existing materials.

Absorption – The conditions of interest for adsorption are those that prevail at maximum sorbent loading, which typically occurs at the bottom of the adsorption column. These may be assumed to be 1 atm total flue-gas pressure (corresponding to a CO₂ partial pressure of 0.13 bar) and 40 °C; however, measured data at other conditions are preferable to estimated data.

Desorption – The conditions of interest for desorption are those that prevail at minimum sorbent loading, which typically occurs at the bottom of the desorption column. Operating pressure and temperature for the desorber/stripper are process-dependent. Measured data at other conditions are preferable to estimated data.

Pressure – The pressure of CO₂ in equilibrium with the sorbent. If the vapor phase is pure CO₂, this is the total pressure; if it is a mixture of gases, this is the partial pressure of CO₂. Note that for a typical PC power plant, the total pressure of the flue gas is about 1 atm and the concentration of CO₂ is about 13.2 percent. Therefore, the partial pressure of CO₂ is roughly 0.132 atm or 0.130 bar.

Packing Density – Ratio of the active sorbent area to the bulk sorbent volume.

Loading – The basis for CO₂ loadings is mass of dry, adsorbate-free sorbent.

Flow Arrangement/Operation – Gas-solid module designs include fixed, fluidized, and moving bed, which result in either continuous, cyclic, or semi-regenerative operation.

Other Parameter Descriptions:

Sorbent Contaminant Resistance – Most, if not all materials used for CO₂ capture, including aqueous amine solvents, alkaline and alkali-based solvents and sorbents, and the amine-based sorbents being developed in this project, have a high affinity for strong acid gases, including sulfur oxide (SO_x), nitrogen oxide (NO_x), and hydrogen chloride (HCl). Considerations have been made regarding how to implement contaminant control within the overall CO₂ capture system. Resistance to trace metal contaminants is unknown at this point.

Sorbent Attrition and Thermal/Hydrothermal Stability – Sorbent attrition will be a function of the process operating environment and physical strength of the sorbent. These will be measured and observed during larger-scale testing campaigns. The base PEI reagent suffers from performance instability at temperatures greater than 110 °C. One of the focuses of this project is to improve the sorbent performance stability.

Flue Gas Pretreatment Requirements – Most likely, the flue gas will require a scrubbing of acid gases prior to entering the CO₂ absorber containing the sorbent being developed in this project.

Sorbent Makeup Requirements – Continuous sorbent makeup will be required during operation of a commercial system in order to replenish sorbent lost to attrition, entrainment, and deactivation by reaction with contaminants.

Waste Streams Generated – As a whole, the process generates few waste streams. It is expected that a continuous purge of sorbent will be required to maintain a desired level of CO₂ removal within the sorbent bed. In addition, sorbent will be lost from the process through attrition and entrainment. The sorbent can either be treated and reused, or disposed of following minimal treatment.

technology advantages

- Potential for reduced parasitic loads and lower capital and operating costs than conventional technology.
- High CO₂ loading capacity.
- Relatively low heat of absorption.
- Reactor design offers superior gas-solid heat and mass transfer characteristics.
- Counter current gas-solids flow maximizes CO₂ driving force.
- Needed process equipment exists and is used industrially.

R&D challenges

- Performance stability above 100 °C is not ideal.
- Further sorbent cost reduction is needed.
- Heat management and novel heat integration strategies are critical to reduce parasitic power losses.
- Water management is critical to avoid condensation.
- Novel process design has not been tested/evaluated at commercial-scale for CO₂ capture.

results to date/accomplishments

- Screened and tested more than 20 commercially available, low-cost support materials using an automated, packed-bed absorption system.
- Identified a low-cost support material yielding a sorbent with comparable performance to expensive, mesoporous silica.
- Demonstrated that adding a small amount of moisture to the regeneration gas dramatically improves the multicycle performance stability of the MBS material.
- Significant sorbent stability improvement demonstrated at 120 °C through process condition selection, sorbent complexation, and cross-linking pathways.
- Sorbent has been prepared through spray drying to make fluidizable particles.
- Demonstrated that water can replace methanol (or any alcohol) as the amine impregnation solvent.
- Developed a fluidized-bed reactor model.
- Completed a preliminary technology feasibility study projecting capture costs of \$36 to \$42/tonne CO₂ captured.
- Bench-scale prototype designed, built, and tested.
- Stable sorbent circulation was tested at various sorbent circulation rates spanning 75–300 kg/h with over 100 hours achieved.
- Heat management tests within the CO₂ absorber of the bench-scale unit confirmed that higher CO₂ capture rates can be achieved through effective heat management.
- The design package for a new staged sorbent regenerator has been completed.

next steps

- Conduct parametric studies of economic/process variables for the bench-scale FMBR system.
- Scaleup novel MBS materials to 1,000 lbs.
- Conduct long-term testing of the prototype system flue gas from a fossil fuel-fired facility.
- Conduct a detailed techno-economic study that results in a high confidence level that the technology can meet U.S. Department of Energy goals.

available reports/technical papers/presentations

Nelson, T., et al., “Advanced Solid Sorbents and Process Designs for Post-Combustion CO₂ Capture,” presented at the 2014 NETL CO₂ Capture Technology Meeting, Pittsburgh, PA, July 2014.

<http://www.netl.doe.gov/File%20Library/Events/2014/2014%20NETL%20CO2%20Capture/T-Nelson-RTI-Advanced-Solid-Sorbents-and-Process-Designs.pdf>.

Nelson, T., et al., “Advanced Solid Sorbents and Process Designs for Post-Combustion CO₂ Capture,” presented at the 2013 NETL CO₂ Capture Technology Meeting, Pittsburgh, PA, July 2013.

<http://www.netl.doe.gov/File%20Library/Events/2013/CO2%20Capture/T-Nelson-RTI-Advanced-Solid-Sorbents.pdf>.

Nelson, T., et al., “Advanced Solid Sorbents and Process Designs for Post-Combustion CO₂ Capture,” presented at the 2012 NETL CO₂ Capture Technology Meeting, Pittsburgh, PA, July 2012.

LOW-COST HIGH-CAPACITY REGENERABLE SORBENT FOR CARBON DIOXIDE CAPTURE FROM EXISTING COAL-FIRED POWER PLANTS

primary project goals

TDA Research, Inc. (TDA) is developing a low-cost, high-capacity carbon dioxide (CO₂) adsorbent to demonstrate its technical and economic viability through sorbent evaluation and optimization, development of sorbent production techniques, and bench-scale testing of the process using actual flue gas.

technical goals

- Optimize chemical composition.
- Optimize physical properties and mechanical integrity of the sorbent to meet the specific requirements of the process.
- Identify optimum operating conditions and process parameters for design calculations.
- Assess the economic viability of the new carbon capture process.

technical content

TDA is developing a low-cost, high-capacity CO₂ adsorbent and demonstrating its technical and economic viability for post-combustion CO₂ capture for existing pulverized coal (PC)-fired power plants. The sorbent consists of a carbon material modified with surface functional groups that remove CO₂ via physical adsorption. It exhibits a much higher affinity to adsorb CO₂ than nitrogen, water, or oxygen, enabling effective CO₂ separation from the flue gas. The sorbent binds CO₂ more strongly than common adsorbents, providing the chemical potential needed to remove the CO₂. However, because CO₂ does not form a true covalent bond with the surface sites, regeneration can be carried out with only a small energy input. The heat input to regenerate the sorbent is only 4.9 kcal/mol of CO₂ (Figure 1), which is much lower than that for chemical absorbents (e.g., 29.9 kcal/mol CO₂ for sodium carbonate) or amine-based solvents (e.g., 14.2 kcal/mol CO₂ for monoethanolamine [MEA]).

technology maturity:

Bench-Scale, Actual Flue Gas

project focus:

Low-Cost, High-Capacity Regenerable Sorbent

participant:

TDA Research, Inc.

project number:

FE0007580

NETL project manager:

Andrew O'Palko
andrew.opalko@netl.doe.gov

principal investigator:

Gokhan Alptekin
TDA Research
galptekin@tda.com

partners:

Babcock & Wilcox,
Gas Technology
Institute, University of
California, Irvine

performance period:

10/1/11 – 9/30/15

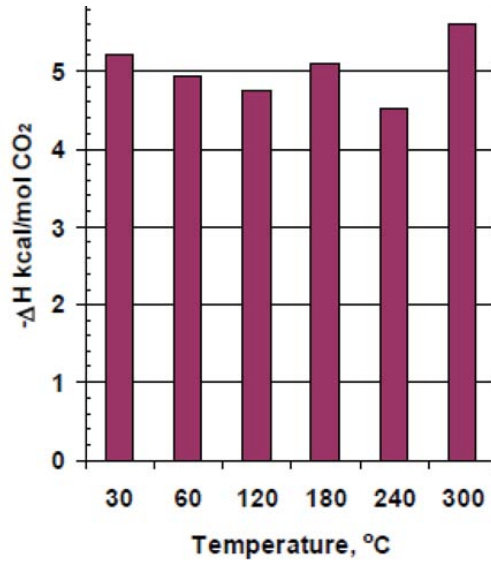

Figure 1: Heat of Adsorption Measurements ($\Delta H_{ads} = 4.9 \pm 0.4$ kcal/mol)

Initial sorbent testing under conditions simulating the environment downstream of a wet flue gas desulfurization unit showed stable CO₂ capacity for more than 220 cycles with no sign of degradation (Figure 2).

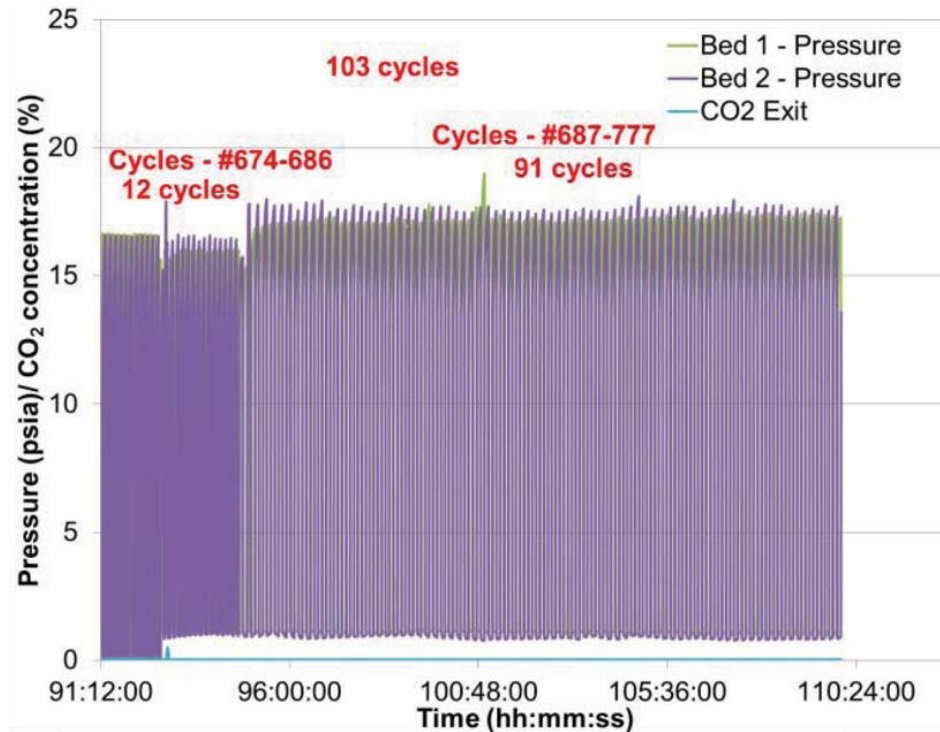

Figure 2: Capacity Testing Under Multiple VSA Cycles—Capacity Maintained Over 770 Cycles (T = 22 °C; half-cycle time = 4–8 min.; P_{ads} = 16 psia; P_{des} = 1 psia; simulated flue gas, 17 vol% CO₂, H₂O = 1.2 vol%)

The presence of acid gases, such as sulfur dioxide (SO₂) and nitrogen oxide (NO_x), and water vapor up to 15 vol% caused no adverse effect on the CO₂ capacity (Figure 3).

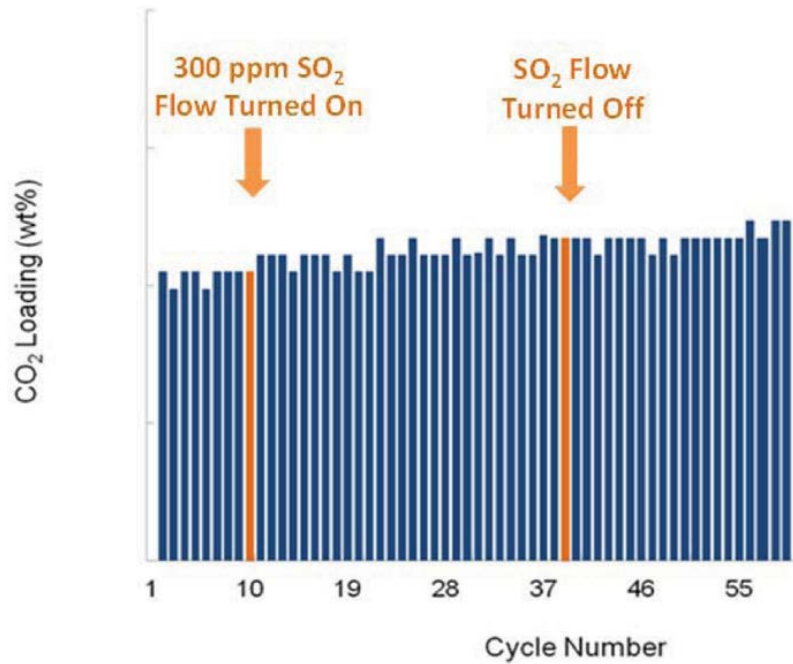

Figure 3: Capacity Analysis in Presence of SO₂ and Water
(adsorption T = 62 °C, 15.2 percent CO₂, 2.8 percent O₂, bal. N₂, sat. with H₂O, 300 ppmv SO₂)

The regeneration of the sorbent and the recovery of CO₂ and its pressurization can then be achieved by several approaches, including temperature swing and vacuum swing. Figure 4 shows a schematic diagram of the process under temperature-swing operation.

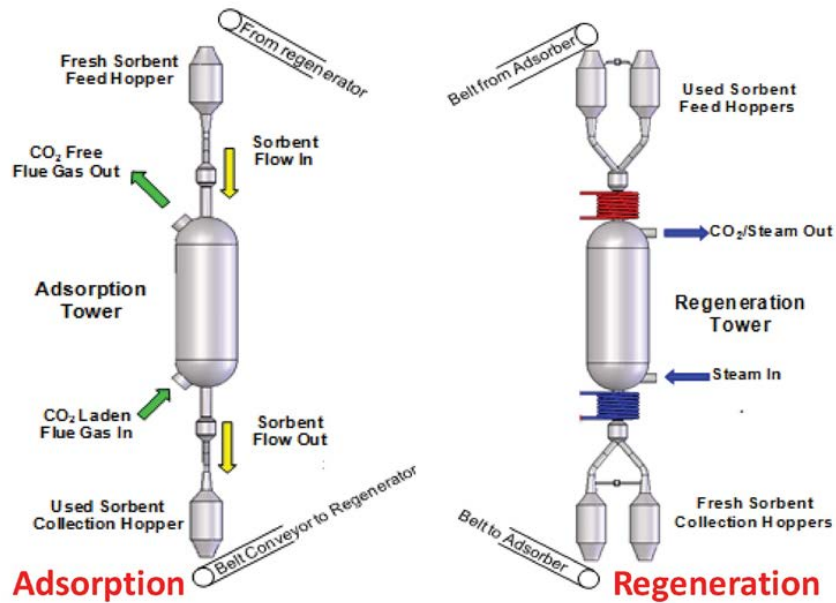

Figure 4: TSA Process Schematic

TABLE 1: ADSORPTION-BASED POST-COMBUSTION CO₂ /N₂ SEPARATIONS

	Units	Current R&D Value	Target R&D Value
Sorbent			
True Density at STP	kg/m ³		
Bulk Density	kg/m ³		
Average Particle Diameter	mm		
Particle Void Fraction	m ³ /m ³		
Packing Density	m ² /m ³		
Solid Heat Capacity at STP	kJ/kg-K	0.93	0.93
Crush Strength	kg _f		
Manufacturing Cost for Solvent	\$/kg		
Absorption			
Pressure	bar	1.02	1.02
Temperature	°C	70	58
Equilibrium CO ₂ Loading	g mol CO ₂ /kg	0.3	0.4
Heat of Absorption	kJ/mol CO ₂	-20.5	-20.5
Desorption			
Pressure	bar	0.204	0.15–0.2
Temperature	°C	70	58
Equilibrium CO ₂ Loading	mol/mol		
Heat of Desorption	kJ/mol CO ₂		
Proposed Module Design		<i>(for equipment developers)</i>	
Flow Arrangement/Operation	—		
Flue Gas Flowrate	kg/hr		
CO ₂ Recovery, Purity, and Pressure	%%/bar	96–97%	
Adsorber Pressure Drop	bar		

Definitions:

STP – Standard Temperature and Pressure (15 °C, 1 atm).

Sorbent – Adsorbate-free (i.e., CO₂-free) and dry material as used in adsorption/desorption cycle.

Manufacturing Cost for Sorbent – “Current” is market price of material, if applicable; “Target” is estimated manufacturing cost for new materials, or the estimated cost of bulk manufacturing for existing materials.

Adsorption – The conditions of interest for adsorption are those that prevail at maximum sorbent loading, which typically occurs at the bottom of the adsorption column. These may be assumed to be 1 atm total flue-gas pressure (corresponding to a CO₂ partial pressure of 0.13 bar) and 40 °C; however, measured data at other conditions are preferable to estimated data.

Desorption – The conditions of interest for desorption are those that prevail at minimum sorbent loading, which typically occurs at the bottom of the desorption column. Operating pressure and temperature for the desorber/stripper are process-dependent. Measured data at other conditions are preferable to estimated data.

Pressure – The pressure of CO₂ in equilibrium with the sorbent. If the vapor phase is pure CO₂, this is the total pressure; if it is a mixture of gases, this is the partial pressure of CO₂. Note that for a typical PC power plant, the total pressure of the flue gas is about 1 atm and the concentration of CO₂ is about 13.2 percent. Therefore, the partial pressure of CO₂ is roughly 0.132 atm or 0.130 bar.

Packing Density – Ratio of the active sorbent area to the bulk sorbent volume.

Loading – The basis for CO₂ loadings is mass of dry, adsorbate-free sorbent.

Flow Arrangement/Operation – Gas-solid module designs include fixed, fluidized, and moving bed, which result in either continuous, cyclic, or semi-regenerative operation.

technology advantages

- The sorbent does competitively adsorb CO₂ over water.
- The heat of adsorption of CO₂ is low (much lower than amine-based solvents; comparable to that of Selexol).
- The net energy loss in sorbent regeneration is expected to be lower than amine scrubbers.

R&D challenges

- Mechanical integrity of the sorbent material at the conditions of use must be demonstrated.
- The gas-solid contactor design must be proven with full capabilities to be demonstrated.

results to date/accomplishments

- The evaluation and optimization of sorbent chemical composition has been completed.
- A low-fidelity process design and system optimization to provide a basis for future experimental and system design work has been developed.
- Optimization of moving-bed and fixed-bed systems underway.
- Long-term sorbent cycling conducted.
- Design of a breadboard prototype test unit in progress.

next steps

- High-fidelity process optimization and design.
- Fabrication of the prototype test unit.
- Concept demonstration.
- System analysis, economic evaluation, and environmental health and safety assessment.

available reports/technical papers/presentations

Alptekin, G., Jayaraman, A., Copeland, R., “Post-Combustion CO₂ Capture System for Existing Coal-Fired Power Plant,” presented at the 2014 NETL CO₂ Capture Technology Meeting, Pittsburgh, PA, July 2014.
<http://www.netl.doe.gov/File%20Library/Events/2014/2014%20NETL%20CO2%20Capture/G-Alptekin-TDA-A-New-Sorbent-For-Post-Combustion.pdf>.

Alptekin, G., Jayaraman, A., Copeland, R., “Post-Combustion CO₂ Capture System for Existing Coal-Fired Power Plant,” presented at the 2013 NETL CO₂ Capture Technology Meeting, Pittsburgh, PA, July 2013.
<http://www.netl.doe.gov/File%20Library/Events/2013/CO2%20Capture/G-Alptekin-TDA-New-Sorbent-for-Post-Combustion.pdf>.

Alptekin, G., Jayaraman, A., Copeland, R., “Post-Combustion CO₂ Capture System for Existing Coal-fired Power Plant,” presented at the 2012 NETL CO₂ Capture Technology Meeting, Pittsburgh, PA, July 2012.

Power Plant Air Pollutant Control “MEGA” Symposium, August 20–23, 2012. Baltimore, MD.

EVALUATION OF SOLID SORBENTS AS A RETROFIT TECHNOLOGY FOR CO₂ CAPTURE FROM COAL-FIRED POWER PLANTS

primary project goals

ADA Environmental Solutions (ADA-ES) is designing and constructing a 1-megawatt (MW) pilot plant to demonstrate solid sorbent-based post-combustion carbon dioxide (CO₂) capture technology to reduce uncertainty of scaleup and accelerate the path to commercialization.

technical goals

Validate and optimize a solid sorbent-based post-combustion CO₂ capture technology through 1-MW slipstream pilot testing and process modeling to enable the conceptual development and techno-economic analysis of a 550-megawatt electric (MWe) facility.

technical content

ADA-ES is developing a post-combustion CO₂ capture process using solid sorbents. The viability assessment included laboratory-scale and 1-kilowatt (kW) pilot-scale sorbent screening and a commercial-scale equipment study in a separate U.S. Department of Energy (DOE) project (DE-NT0005649). The specific work completed under the viability assessment included:

Evaluated more than 100 potential CO₂ sorbents, which were procured from various CO₂ solid sorbent developers worldwide. Sorbents were evaluated on the basis of cyclic stability, CO₂ capacity, working CO₂ capacity, availability, cost of raw materials, production process, manageable disposal costs (low toxicity), interaction with flue gas constituents, adequate physical strength, and theoretical regeneration energy. The CO₂ sorbents were investigated in such a way to assess their respective performances in a temperature swing adsorption (TSA) process. Table 1 displays the key properties used to evaluate CO₂ sorbents.

technology maturity:

Pilot-Scale, 1-MW
Slipstream of Actual Flue
Gas

project focus:

Solid Sorbents as Retrofit
Technology

participant:

ADA-ES

project number:

NT0004343
NT0005649

NETL project manager:

Bruce Lani
bruce.lani@netl.doe.gov

principal investigator:

Sharon M. Sjoström
ADA-ES, Inc.
sharons@adaes.com

partners:

Electric Power Research
Institute Southern
Company
Stantec Consulting, Ltd.

performance period:

9/30/08 – 9/30/15

TABLE 1: KEY PROPERTIES USED TO EVALUATE CO₂ SORBENTS

	Current Range	Goal
True Density at Sorbent Particle Size (mm)	highly varied and controllable	≈0.1–5
Sorbent Surface Area (m ² /g)	0.5–3,000	0.5–1,500
Sorbent Active Component Concentration (wt%)	5–60	10–100
Shape of Sorbent	varied	spherical
Density of Sorbent (g/cm ³ [lb/ft ³])	0.2–0.6 [15–40]	dependent on process design
Mechanical Strength	not reported	dependent on process design
Attrition Fines: Form, Processing, and Fate	not reported	low attrition, potential for reuse desired, non-volatile, non-hazardous disposal

- The lab-scale tests typically consisted of <3 grams of the adsorbents exposed to simulated flue gas and then regenerated by a temperature swing with a humid nitrogen sweep gas. For the adsorption step, the simulated flue gas was 55 °C (130 °F) with oxygen and CO₂ concentrations of 4 percent and 12 percent, respectively. The moisture level was varied (0 percent, 50 percent, or 90 percent relative humidity). The regeneration temperature was varied between 65 and 250 °C (150 and 480 °F).
- A 1-kW pilot was constructed to more thoroughly investigate the most positively rated adsorbents tested at the laboratory scale. More than 90 percent CO₂ removal was achieved repeatedly in batch mode with one supported amine sorbent at two field sites.
- In a concurrent effort to the sorbent evaluation, a technology survey was completed to identify potential commercial and conceptual processes and equipment options for use in retrofitting the existing fleet of coal-fired power plants for post-combustion CO₂ capture. Different equipment options were selected for the adsorption, regeneration, and cooling sections and pieced together to form the conceptual design of the commercial-scale process. The technologies selected were proven the most reliable, cost-effective, and versatile options available.

The current project (DE-FE0004343) includes development of a commercial-scale (550 MWe) conceptual process and validation using a 1 MWe-scale pilot. The information gained from the 1-MW pilot operation will be used to complete a technical and economic analysis of the commercial-scale process. Three project phases were planned:

- In Phase I, a 550-MW conceptual design was developed and a 1-MW pilot plant was designed. A simplified sketch of the commercial concept integrated into an existing coal-fired power plant is presented in Figure 1. The sorbent-based CO₂ capture process is implemented immediately upstream of the stack. Based on the properties of one promising sorbent, four adsorption/regeneration trains are required to remove 90 percent of the CO₂ being exhausted from a 550-MWe subcritical coal-fired power plant.

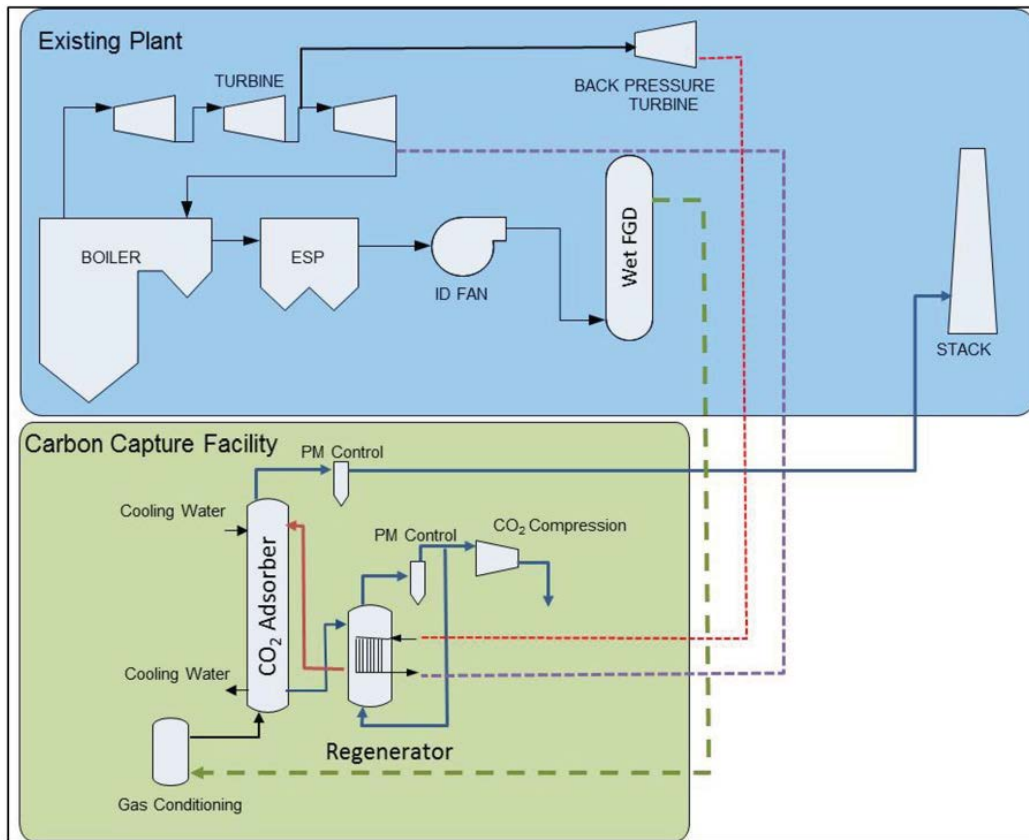

Figure 1: Process Flow Diagram of a Subcritical PC Power Plant Retrofitted with a Solid-Based CO₂ Capture Process

The process was designed to minimize CO₂ capture costs, primarily by providing the sorbent with the conditions necessary to achieve the highest possible CO₂ working capacity. This is accomplished through two important process characteristics: (1) isothermal operation and (2) approaching counter-current gas/solids contacting in the adsorber. Note that in Figure 1, the regenerator is shown as a single stage, but multiple stages could also be used if it was economically advantageous to use steam to drive off more CO₂ during regeneration. Improvements in sorbent CO₂ capture performance or altered operating conditions could decrease the overall process costs, but for all sorbents it is important to evaluate whether the process can be improved further by incorporating heat integration.

- Phase II includes 1-MWe detailed engineering, construction, installation, and tie-in of the pilot plant at a coal-fired power plant site. A 3-D model of the pilot is shown in Figure 2.



Figure 2: 3-D Model of 1-MWe Pilot of CO₂ Capture Process

- Phase III will include field-testing with the 1-MWe pilot, system analysis, and a techno-economic assessment of the full-scale process. Planned field-testing includes parametric studies and up to 2 months of continuous pilot operation to validate pilot plant performance.

Specific objectives for the current project include:

- Demonstrate the technical, economic, and energy benefits of a promising CO₂ capture technology.
- Develop performance data through the operation of the system on flue gas, including temperature control and optimized system heat recovery.
- Measure process conditions, including sorbent heat of reaction, sorbent working capacity, sorbent attrition, system pressure drop, and CO₂ capture.
- Assess sorbent performance sensitivity to flue gas constituents.
- Operate continuously for at least 2 months to identify operating and maintenance issues and system reliability.
- Remove at least 90 percent of the incoming CO₂ from the flue gas.
- Produce high-purity CO₂ that will be capable of meeting pipeline standards.
- Conduct a techno-economic analysis of the commercial design.

The sorbent and process properties identified to date are provided in Table 2.

TABLE 2: PROCESS PARAMETERS FOR SOLID SORBENT

	Units	Current R&D Value	Target R&D Value
Sorbent			
True Density at STP	kg/m ³	646	646
Bulk Density	kg/m ³	453	453
Average Particle Diameter	mm	0.1	0.1
Particle Void Fraction	m ³ /m ³	0.418	0.418
Packing Density	m ² /m ³	N/A	N/A
Solid Heat Capacity at STP	kJ/kg-K	1.05	1.05
Crush Strength	kgf	2.2	2.2
Manufacturing Cost for Sorbent	\$/kg	≈\$150	<\$10
Adsorption			
Pressure	bar	1	1
Temperature	°C	40	40
Equilibrium CO ₂ Loading	g mol CO ₂ /kg	2.4	6 to 7
Heat of Adsorption	kJ/mol CO ₂	-60	-60
Desorption			
Pressure	bar	1	1
Temperature	°C	120	<100
Equilibrium CO ₂ Loading	mol/mol	0.8	0.8
Heat of Desorption	kJ/mol CO ₂	60	60
Proposed Module Design		<i>(for equipment developers)</i>	
Flow Arrangement/Operation	—	fluidized bed, temperature swing adsorption	
Flue Gas Flowrate	kg/hr	3,500	
CO ₂ Recovery, Purity, and Pressure	%/%/bar	90%, 85% CO ₂ , 15% H ₂ O, ambient	
Adsorber Pressure Drop	bar	0.55	

Definitions:

STP – Standard Temperature and Pressure (15 °C, 1 atm).

Sorbent – Adsorbate-free (i.e., CO₂-free) and dry material as used in adsorption/desorption cycle.

Manufacturing Cost for Sorbent – “Current” is market price of material, if applicable; “Target” is estimated manufacturing cost for new materials, or the estimated cost of bulk manufacturing for existing materials.

Adsorption – The conditions of interest for adsorption are those that prevail at maximum sorbent loading, which typically occurs at the bottom of the adsorption column. These may be assumed to be 1 atm total flue-gas pressure (corresponding to a CO₂ partial pressure of 0.13 bar) and 40 °C; however, measured data at other conditions are preferable to estimated data.

Desorption – The conditions of interest for desorption are those that prevail at minimum sorbent loading, which typically occurs at the bottom of the desorption column. Operating pressure and temperature for the desorber/stripper are process-dependent. Measured data at other conditions are preferable to estimated data.

Pressure – The pressure of CO₂ in equilibrium with the sorbent. If the vapor phase is pure CO₂, this is the total pressure; if it is a mixture of gases, this is the partial pressure of CO₂. Note that for a typical pulverized coal (PC) power plant, the total pressure of the flue gas is about 1 atm and the concentration of CO₂ is about 13.2 percent. Therefore, the partial pressure of CO₂ is roughly 0.132 atm or 0.130 bar.

Packing Density – Ratio of the active sorbent area to the bulk sorbent volume.

Loading – The basis for CO₂ loadings is mass of dry, adsorbate-free sorbent.

Flow Arrangement/Operation – Gas-solid module designs include fixed, fluidized, and moving bed, which result in either continuous, cyclic, or semi-regenerative operation.

Estimated Cost – Basis is kg/hr of CO₂ in CO₂-rich product gas; assuming targets are met.

Other Parameter Descriptions:

Chemical/Physical Sorbent Mechanism – The sorbent selected for this project is an ion exchange resin with a primary benzyl amine that removes CO₂ in a TSA process. It is important to note that other supported amine sorbents with similar enthalpy of adsorption and physical properties could also be used in the same process without major equipment changes.

One of the most important sorbent properties for post-combustion CO₂ capture is the CO₂ working capacity. Isotherms were generated using experimental data and the Langmuir isotherm model, which are provided in Figure 3. To calculate the CO₂ working capacity of this sorbent, the adsorption conditions are assumed to be 40 °C and PCO₂ = 0.15 bar, while the regeneration conditions are assumed to be 120 °C and 0.81 bar (note that the CO₂ in the regenerator exhaust will be slightly diluted with desorbing moisture). Using the isotherms provided in Figure 3, the CO₂ loading under adsorption conditions is approximately 10.5 g CO₂/100 g fresh sorbent, while the CO₂ loading under the regeneration conditions is approximately 3.5 g CO₂/100 g fresh sorbent; the CO₂ working capacity is approximately 7 g CO₂/100 g fresh sorbent, which is nearly an 80 percent improvement versus the working capacity of aqueous monoethanolamine provided in the 2010 version of the DOE baseline report.

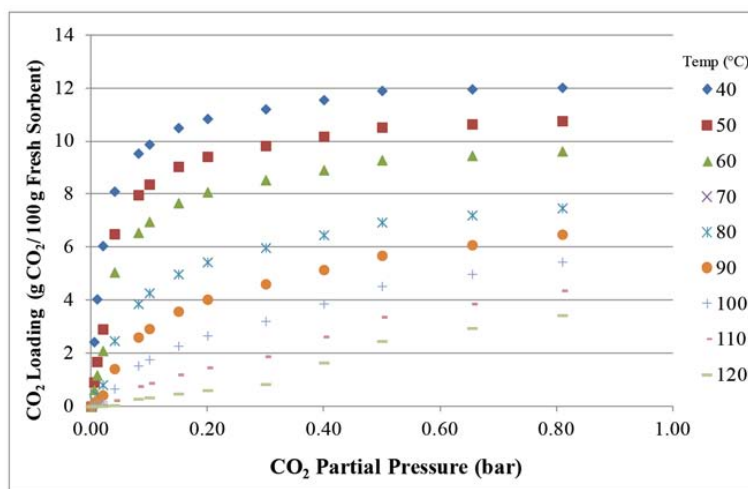

Figure 3: Sorbent Isotherms

Sorbent Contaminant Resistance – Amines will react with sulfur dioxide (SO₂) in the flue gas. The selected sorbent will react with SO₂ and, as a result, the overall working capacity for CO₂ will decrease. However, this is a reversible reaction and the sorbent can be regenerated to recover CO₂ capture effectiveness.

Sorbent Attrition and Thermal/Hydrothermal Stability – Based on laboratory testing, the selected sorbent is expected to have low mechanical attrition. Comparisons to fluid catalytic cracking (FCC) catalyst attrition are favorable. The moisture uptake on the sorbent is important because it results in an increase in the regenerator heat duty due to the enthalpy of vaporization/condensation (assuming that the H₂O is physically adsorbed). In addition, in the regenerator, the released H₂O will necessitate the addition of condensers to separate the H₂O from the CO₂ exhaust. This sorbent demonstrates a small (≈ 0.9 g H₂O/100 g fresh sorbent under expected 1-MWe pilot operating conditions) H₂O working capacity.

Flue Gas Pretreatment Requirements – A secondary scrubber has been incorporated into the pilot design to reduce the flue gas SO₂. An assessment of the cost-benefit of scrubbing SO₂ versus regenerating the sorbent that has reacted with SO₂ to recover CO₂ capture effectiveness must be conducted to determine the commercial process design and operating details.

Sorbent Makeup Requirements – Current estimates used in cost projections are to replace the sorbent nominally once per year. Further testing is required, including pilot testing to refine the makeup requirements.

Waste Streams Generated – Waste streams will include spent sorbent, flue gas scrubber blow-down, and flue gas cooler condensate.

Process Design Concept – A simple schematic of the design of the 1-MWe pilot being designed and constructed is provided in Figure 4. In the schematic, three fluidized beds are shown for adsorption, but the actual number of fluidized beds must be selected based on the sorbent. However, while the number of beds may change, it is important to remember that the heat transfer surface area is based on the sensible heat that must be removed, the enthalpy of adsorption, and the amount of CO₂ being adsorbed. The regenerator is a single fluidized bed. Only one stage is necessary because the goal of the regenerator is to generate high partial pressure CO₂ and no stripping steam is used.

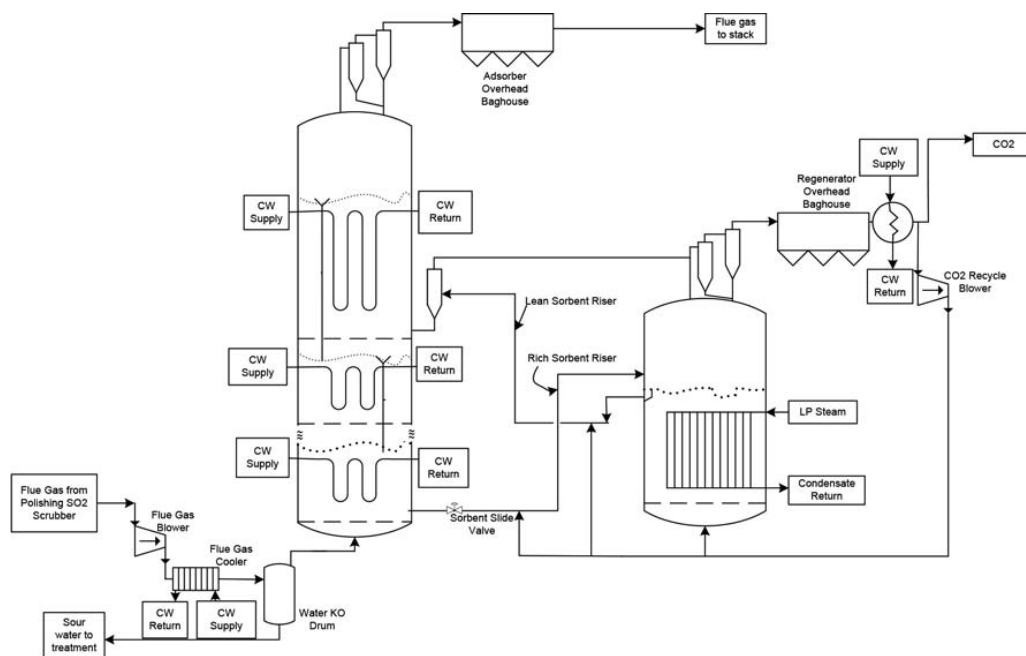

Figure 4: Schematic of ADA's CO₂ Capture Temperature Swing Adsorption System

Proposed Module Design – The CO₂ capture module will be located downstream of the plant's existing SO₂ scrubber. The gas stream from which CO₂ will be removed is representative of that from a coal-fired power plant with nominal conditions of PCO₂ = 0.13 bar and T = 55 °C. The adsorber is designed to operate isothermally at 40 °C. The exhaust pressure for regeneration is approximately ambient pressure. The minimum superficial velocity of the flue gas will be limited to 1.2 m/s (4.0 ft/s) to minimize the number and footprint of reactors, and thus capital costs. Pneumatic conveying will be utilized for all required material conveying to increase reliability, decrease O&M costs, and increase technology acceptance. Because the sorbent and flue gas are contacted in a system that approaches counter-current flow, CO₂ working capacity can be maximized. In addition, the heat transfer has been optimized through the use of bubbling fluidized beds. The optimal mixing that is characteristic of bubbling fluidized beds also translates into effective gas/solids contacting. The design of the system employed established methods and principles used for gas-solid systems, including gas distribution, in-bed heat transfer, risers, standpipes, cyclones, and diplegs. Large-scale, two-stage fluidized beds have been used commercially for FCC processes. However, not all aspects of the design are commercially available. Wherever necessary, novel and innovative components, such as the trays used to support the fluidized beds, have been developed.

technology advantages

- Compared to an aqueous amine system:
 - No corrosion inhibitors are required.
 - Less water waste will be generated.
 - No process makeup water will be required.
 - Amine volatilization will be reduced or eliminated (indicated during laboratory testing and will be evaluated during 1-MWe pilot testing).
- Reduction in the regeneration energy requirements by minimizing heat input:
 - The heat capacity of solids is nominally 25 percent of liquids (heat recovery for solids has not been developed for this application).
 - The latent heat of vaporization is minimized (no liquid solvent is involved).
- High sorbent CO₂ capacities have been demonstrated (lab scale).
- Fundamental sorbent chemistry is well known (e.g., amine).
- Components of process equipment are mature (e.g., circulating fluidized bed).

R&D challenges

- Similar to aqueous amines, long-term stability of sorbents when exposed to flue gas is of concern. Laboratory tests indicate sorbent performance can be recovered using a secondary system.
- Availability of sorbents including the number of suppliers. Many developers are currently materials and several show promise in laboratory testing. Multiple suppliers are expected to emerge with a commercial market.
- Ability to scale up sorbent manufacturing without impacting performance. Although the specific recipe is unique, the current sorbent is produced using a commercial-scale ion exchange resin manufacturing process. Larger-scale production lines should not be an issue for this material. Cost controls will be realized by developing a manufacturing process specific to this recipe.
- Ability to design a process that can control sorbent temperatures and counteract changes resulting from the heat of reaction, potential erosion, and/or corrosion of process equipment.

results to date/accomplishments

- Selected supported amines as the sorbent family for the 1-MW pilot. Selected an ion exchange resin with optimal physical and chemical characteristics for this application.
- Selected a staged fluidized bed for the adsorber design and a single fluidized bed for the regenerator design.
- Completed a 550-MWe conceptual design.
- 1-MWe pilot plant detailed engineering design, fabrication and installation was completed.
- Sorbent has been manufactured.

next steps

- Complete operating, commissioning/startup, and testing procedures.
- Demonstrate pilot-plant operation.
- Complete techno-economic assessment of technology.

available reports/technical papers/presentations

Sjostrom, S., “Evaluation of Solid Sorbents as a Retrofit Technology for CO₂ Capture,” presented at the 2014 NETL CO₂ Capture Technology Meeting, Pittsburgh, PA, July 2014.

<http://www.netl.doe.gov/File%20Library/Events/2014/2014%20NETL%20CO2%20Capture/S-Sjostrom-ADA-Evaluation-of-Solid-Sorbents.pdf>.

Sjostrom, S., “Evaluation of Solid Sorbents as a Retrofit Technology for CO₂ Capture,” presented at the 2013 NETL CO₂ Capture Technology Meeting, Pittsburgh, PA, July 2013. <http://www.netl.doe.gov/File%20Library/Events/2013/CO2%20Capture/S-Sjostrom-ADA-Solid-Sorbents-as-Retrofit-Technology.pdf>.

Starns, T.; Sjostrom, S.; Krutka, H.; Wilson, C.; and Ivie, M., “Solid Sorbents as a Retrofit CO₂ Capture Technology: Update on 1-MWe Pilot Progress,” presented at the MEGA Conference, Baltimore, MD, August 2012.

Krutka, H.; Starns, T.; and Sjostrom, S., “Solid Sorbents as a Retrofit CO₂ Capture Technology: 1-MW Pilot Design,” papers #527, Air & Waste Management Association Annual Conference, San Antonio, TX, June, 2012.

Krutka, H.; Sjostrom, S.; Krutka, H.; Starns, T.; Dillon, M.; and Silverman, R., “Post-Combustion CO₂ Capture Using Solid Sorbents: 1-MWe Pilot Evaluation,” Energy Procedia, 2012, accepted.

Sjostrom, S., “Evaluation of Solid Sorbents as a Retrofit Technology for CO₂ Capture,” presented at the 2012 NETL CO₂ Capture Technology Meeting, Pittsburgh, PA, July 2012.

Sjostrom, S., “Evaluation of Solid Sorbents as a Retrofit Technology for CO₂ Capture,” presented at the 2011 NETL CO₂ Capture Technology Meeting, Pittsburgh, PA, August 2011.

<https://www.netl.doe.gov/File%20Library/research/coal/carbon%20capture/22Aug11-Starns-ADAES-Solid-Sorbents-Retrofit.pdf>

Sjostrom, S.; Krutka, H.; Starns, T.; and Campbell, T., “Pilot Test Results of Post-Combustion CO₂ Capture Using Solid Sorbents,” Energy Procedia, 2011, 4, 1584-1592.

Sjostrom, S., and Krutka, H., “Evaluation of Solid Sorbents as a Retrofit Technology for CO₂ Capture,” Fuel, 2010, 89, 1298-1306. <http://www.sciencedirect.com/science/article/pii/S0016236109005286>.

Sjostrom, S., “Evaluation of Solid Sorbents as a Retrofit Technology for CO₂ Capture from Coal-Fired Power Plants,” presented at the 2010 NETL CO₂ Capture Technology Meeting, Pittsburgh, PA, September 2010.

<http://www.netl.doe.gov/File%20Library/research/coal/carbon%20capture/Sharon-Sjostrom---ADA-Environmental-Solutions.pdf>.

Sjostrom, S.; Krutka, H.; Campbell, T.; and Starns, T., “Solid Sorbents as a Retrofit CO₂ Capture Technology: Results from Field Testing,” presented at the Power Plant Air Pollutant Control “MEGA” Symposium, Baltimore, MD, August 30–September 2, 2010.

Sjostrom, S.; Campbell, T.; Krutka, H.; and Starns, T., “Solid Sorbents as a Retrofit CO₂ Capture Technology: Results from Field Testing,” Paper #2010-A-131 submitted for presentation at the Power Plant Air Pollutant Control “MEGA” Symposium, Baltimore, MD, August 30–September 2, 2010.

Martin, C.; Sjostrom, S.; Krutka, H.; Richard, M.; and Cameron, D., Topical Report 1, 2, and 3: Technology Survey, Screening, and Final Selection, Reporting Period: October 1, 2008–January 31, 2010 for U.S. Department of Energy Contract No. DE-NT0005649, July 2010.

Sjostrom, S., and Krutka, H., “Evaluation of Solid Sorbents as a Retrofit Technology for CO₂ Capture,” Fuel, Volume 89, Issue 6, Advanced Fossil Energy Utilization, June 2010, Pages 1298-1306.

<http://www.sciencedirect.com/science/article/pii/S0016236109005286>.

Sjostrom, S.; Campbell, T.; Krutka, H.; and Starns, T., “Post-Combustion CO₂ Control Using Solid Sorbents: Results from 1-kW Pilot Tests,” presented at the Ninth Annual Conference on Carbon Capture and Sequestration, May 2010.

Sjostrom, S.; Campbell, T.; Krutka, H.; and O’Palko, A., “Solid Sorbents as a Retrofit CO₂ Capture Technology: Results from Pre-Pilot Field Testing,” presented at the Air Quality VII Conference, Arlington, VA, October 2009.

Sjostrom, S., “Evaluation of Solid Sorbents as a Retrofit Technology for CO₂ Capture from Coal-Fired Power Plants – Project Overview,” presented at the Annual NETL CO₂ Capture Technology for Existing Plants R&D Meeting, PA, Pennsylvania, March 2009.

Krutka, H.; Sjostrom, S.; and Bustard, C.J., "Results from Lab and Field Testing of Novel CO₂ Sorbents for Existing Coal-Fired Power Plants," Power Plant Air Pollutant Control "Mega" Symposium, Baltimore, MD, August 2008.

Summary of Post-Combustion CO₂ Capture Technologies for Existing Coal-Fired Power Plants, Air & Waste Management Association Annual Conference, paper #808, Portland, OR, June 2008.

OPTIMIZING THE COSTS OF SOLID SORBENT-BASED CO₂ CAPTURE PROCESS THROUGH HEAT INTEGRATION

primary project goals

ADA Environmental Solutions (ADA-ES) is investigating heat recovery for a temperature-swing-adsorption (TSA) capture process, including the use of a cross-heat exchanger to recover sensible heat from the sorbent leaving the regenerator. Recovering heat generated by the sorbent during the capture process would reduce the energy penalty and overall cost for carbon dioxide (CO₂) capture.

technical goals

- Evaluate multiple cross-heat exchanger configurations and identify the most cost-effective option through computational modeling.
- Optimize approach temperature and cross-heat exchanger design.
- Assess the economic viability of the new carbon capture process.

technical content

Cross-heat exchangers are standard features of solvent-based processes; large-scale heat exchangers appropriate for solids in this application currently do not exist. Although the fundamental components for solids-based heat exchangers are commercially available, the design details and integration approach is being developed and optimized to ensure that the additional equipment capital costs do not outweigh benefits associated with reduced overall energy penalty. Figure 1 is a concept drawing for the cross-heat exchanger.

technology maturity:

Bench-Scale Testing at Simulated Full-Scale Process Conditions

project focus:

Cross-Heat Exchanger for Sorbent-Based CO₂ Capture

participant:

ADA-ES, Inc.

project number:

DE-FE0012914

NETL project manager:

Bruce Lani
bruce.lani@netl.doe.gov

principal investigator:

Sharon Sjostrom
ADA-ES, Inc.
sharons@adaes.com

partners:

Solex Thermal Science,
Lehigh University–Energy
Research Center,
Technip Stone and
Webster Process
Technologies

performance period:

10/1/13 – 6/15/15

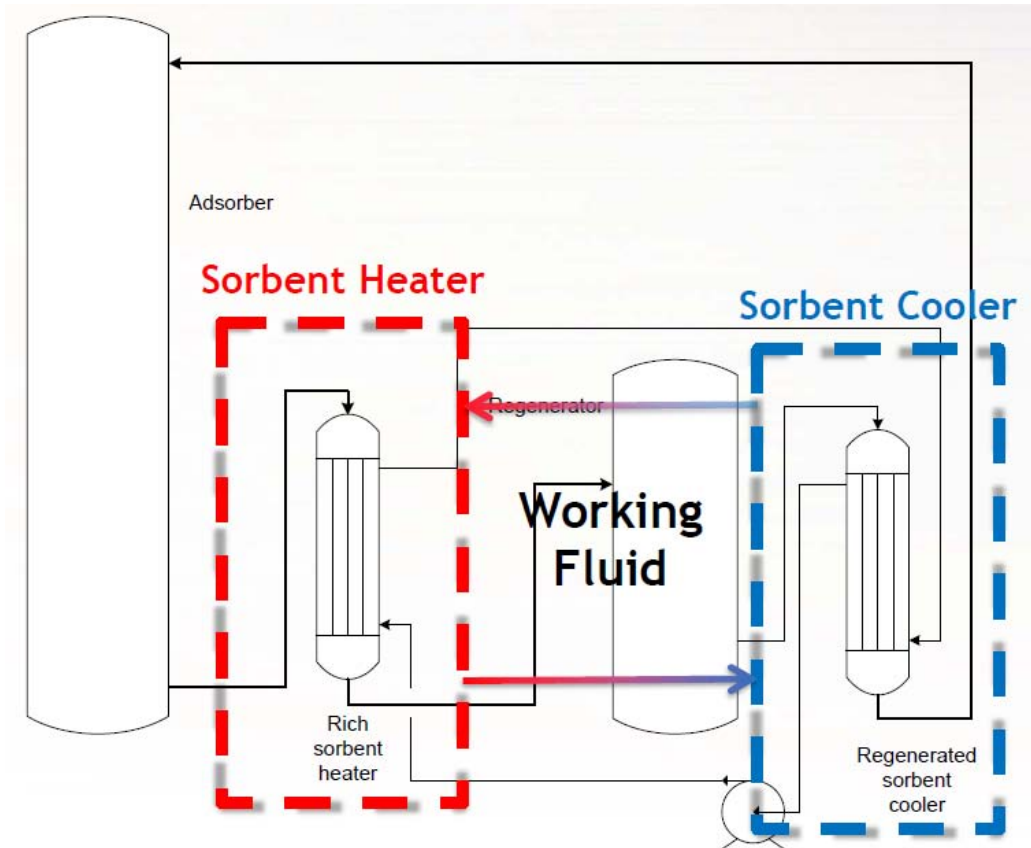

Figure 1: Cross-Heat Exchanger Concept

ADA-ES, teamed with Solex Thermal Science, Technip Stone and Webster Process Technologies, and the Energy Research Center at Lehigh University, is optimizing its promising dry sorbent-based post-combustion capture process—the ADA_{sorb}TM process—developed under another DOE-funded project (DE-FE0004343) by evaluating heat integration opportunities as well as working to develop an overall optimized process. The concepts, however, will be applicable to other TSA processes. The optimization study includes a sensitivity analysis across a range of sorbent properties to identify cost and energy demand trends so that the general conclusions can be applied to most sorbent-based CO₂ capture processes. The team is evaluating heat integration opportunities and optimizing the process by:

- Bench-scale testing the heat exchanger concept with a single sorbent to collect the data required for scale-up modeling and the subsequent computational modeling.
- Modeling using ASPEN Plus and custom tools to determine the optimal operating conditions for the heat exchanger in a moving-bed and fluidized bed arrangements integrated into the overall CO₂ capture process to minimize capital and operating cost.
- Process modeling to assess the viability of heat integration options (with the power plant and the CO₂ compressors).
- Optimization of the flue gas moisture level.
- Adsorber and regenerator design assessment to reduce pressure drop.
- A techno-economic assessment of the optimized equipment and operating conditions incorporated into a 550-MWe supercritical plant using ADA's existing techno-economic model developed under DE-FE0004343; the techno-economic assessment will also include identification of sorbent properties to meet the DOE's CO₂ capture cost goals.

Lehigh's ASPEN model of the ADAorb™ process including the cross-heat exchanger is shown in Figure 2.

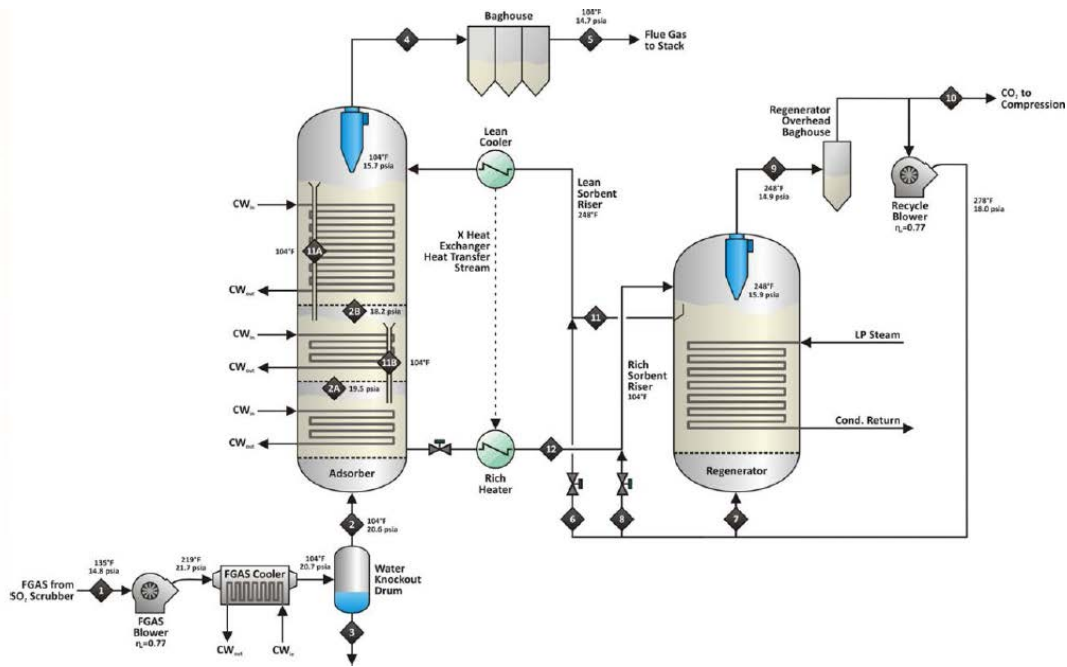

Figure 2: Lehigh's Aspen Model with Cross-Heat Exchanger

The sorbent and process properties identified to date are provided in Table 1.

TABLE 1: ADA-ES SOLID SORBENT PARAMETERS

	Units	Current R&D Value	Target R&D Value
Sorbent			
True Density at STP	kg/m ³	646	646
Bulk Density	kg/m ³	453	453
Average Particle Diameter	mm	0.18	0.18
Particle Void Fraction	m ³ /m ³	0.418	0.418
Packing Density	m ² /m ³	N/A	N/A
Solid Heat Capacity at STP	kJ/kg-K	1.05	1.05
Crush Strength	kg _f	2.2	2.2
Manufacturing Cost for Sorbent	\$/kg	\$150	\$10
Adsorption			
Pressure	bar	1	1
Temperature	°C	40	40
Equilibrium CO ₂ Loading	g mol CO ₂ /kg	2.4	7.2
Heat of Adsorption	kJ/mol CO ₂	-60	-60
Desorption			
Pressure	bar	1	1
Temperature	°C	120	<100
Equilibrium CO ₂ Loading	g mol CO ₂ /kg	0.8	0.6
Heat of Desorption	kJ/mol CO ₂	60	60

TABLE 1: ADA-ES SOLID SORBENT PARAMETERS

	Units	Current R&D Value	Target R&D Value
Proposed Module Design		<i>(for equipment developers)</i>	
Flow Arrangement/Operation	—	fluidized bed, temperature swing adsorption	
Flue Gas Flowrate	kg/hr	3,500	
CO ₂ Recovery, Purity, and Pressure	%%/bar	90%, 85% CO ₂ , 15% H ₂ O, ambient	
Adsorber Pressure Drop	bar	0.55	

Definitions:

STP – Standard Temperature and Pressure (15 °C, 1 atm).

Sorbent – Adsorbate-free (i.e., CO₂-free) and dry material as used in adsorption/desorption cycle.

Manufacturing Cost for Sorbent – “Current” is market price of material, if applicable; “Target” is estimated manufacturing cost for new materials, or the estimated cost of bulk manufacturing for existing materials.

Adsorption – The conditions of interest for adsorption are those that prevail at maximum sorbent loading, which typically occurs at the bottom of the adsorption column. These may be assumed to be 1 atm total flue-gas pressure (corresponding to a CO₂ partial pressure of 0.13 bar) and 40 °C; however, measured data at other conditions are preferable to estimated data.

Desorption – The conditions of interest for desorption are those that prevail at minimum sorbent loading, which typically occurs at the bottom of the desorption column. Operating pressure and temperature for the desorber/stripper are process-dependent. Measured data at other conditions are preferable to estimated data.

Pressure – The pressure of CO₂ in equilibrium with the sorbent. If the vapor phase is pure CO₂, this is the total pressure; if it is a mixture of gases, this is the partial pressure of CO₂. Note that for a typical PC power plant, the total pressure of the flue gas is about 1 atm and the concentration of CO₂ is about 13.2 percent. Therefore, the partial pressure of CO₂ is roughly 0.132 atm or 0.130 bar.

Packing Density – Ratio of the active sorbent area to the bulk sorbent volume.

Loading – The basis for CO₂ loadings is mass of dry, adsorbate-free sorbent.

Flow Arrangement/Operation – Gas-solid module designs include fixed, fluidized, and moving bed, which result in continuous, cyclic, or semi-regenerative operation.

Other Parameter Descriptions:

Chemical/Physical Sorbent Mechanism – The sorbent selected for this project is an ion exchange resin with a primary benzyl amine that removes CO₂ in a TSA process. It is important to note that other supported amine sorbents with similar enthalpy of adsorption and physical properties could also be used in the same process without major equipment changes.

One of the most important sorbent properties for post-combustion CO₂ capture is the CO₂ working capacity. Isotherms were generated using experimental data and the Langmuir isotherm model, which are provided in Figure 3. To calculate the CO₂ working capacity of this sorbent, the adsorption conditions are assumed to be 40 °C and PCO₂ = 0.15 bar, while the regeneration conditions are assumed to be 120 °C and 0.81 bar (note that the CO₂ in the regenerator exhaust will be slightly diluted with desorbing moisture). Using the isotherms provided in Figure 3, the CO₂ loading under adsorption conditions is approximately 10.5 g CO₂/100 g fresh sorbent, while the CO₂ loading under the regeneration conditions is approximately 3.5 g CO₂/100 g fresh sorbent; the CO₂ working capacity is approximately 7 g CO₂/100 g fresh sorbent, which is nearly an 80 percent improvement versus the working capacity of aqueous monoethanolamine provided in the 2010 version of the DOE baseline report.

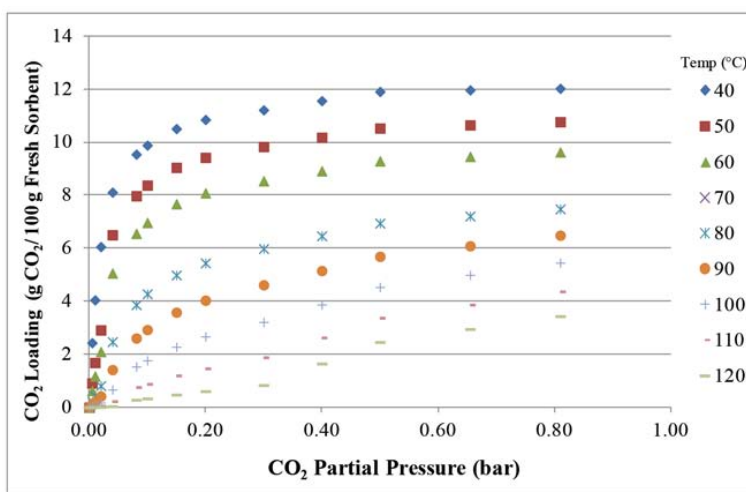

Figure 3: Sorbent Isotherms

Sorbent Contaminant Resistance – Amines will react with sulfur dioxide (SO₂) in the flue gas. The selected sorbent will react with SO₂ and, as a result, the overall working capacity for CO₂ will decrease. However, this is a reversible reaction and the sorbent can be regenerated to recover CO₂ capture effectiveness.

Sorbent Attrition and Thermal/Hydrothermal Stability – Based on laboratory testing, the selected sorbent is expected to have low mechanical attrition. Comparisons to fluid catalytic cracking (FCC) catalyst attrition are favorable. The moisture uptake on the sorbent is important because it results in an increase in the regenerator heat duty due to the enthalpy of vaporization/condensation (assuming that the H₂O is physically adsorbed). In addition, in the regenerator, the released H₂O will necessitate the addition of condensers to separate the H₂O from the CO₂ exhaust. This sorbent demonstrates a small (≈ 0.9 g H₂O/100 g fresh sorbent under expected 1-MWe pilot operating conditions) H₂O working capacity.

Flue Gas Pretreatment Requirements – A secondary scrubber has been incorporated into the pilot design to reduce the flue gas SO₂. An assessment of the cost-benefit of scrubbing SO₂ versus regenerating the sorbent that has reacted with SO₂ to recover CO₂ capture effectiveness must be conducted to determine the commercial process design and operating details. Additional work has examined the possibility of regenerating sorbents contaminated by acid gases such as SO₂ so that the sorbents may be reused in the process.

Sorbent Makeup Requirements – Current estimates used in cost projections are to replace the sorbent nominally once per year. Further testing is required, including pilot testing to refine the makeup requirements.

Waste Streams Generated – Waste streams will include spent sorbent, flue gas scrubber blow-down, and flue gas cooler condensate.

Process Design Concept – Flowsheet/block flow diagram included above.

Proposed Module Design – The CO₂ capture module will be located downstream of the plant’s existing SO₂ scrubber. The gas stream from which CO₂ will be removed is representative of that from a coal-fired power plant with nominal conditions of PCO₂ = 0.13 bar and T = 55 °C. The adsorber is designed to operate isothermally at 40 °C. The exhaust pressure for regeneration is approximately ambient pressure. The minimum superficial velocity of the flue gas will be limited to 1.2 m/s (4.0 ft/s) to minimize the number and footprint of reactors, and thus capital costs. Pneumatic conveying will be utilized for all required material conveying to increase reliability, decrease O&M costs, and increase technology acceptance. Because the sorbent and flue gas are contacted in a system that approaches counter-current flow, CO₂ working capacity can be maximized. In addition, the heat transfer has been optimized through the use of bubbling fluidized beds. The optimal mixing that is characteristic of bubbling fluidized beds also translates into effective gas/solids contacting. The design of the system employed established methods and principles used for gas-solid systems, including gas distribution, in-bed heat transfer, risers, standpipes, cyclones, and diplegs. Large-scale, two-stage fluidized beds have been used commercially for FCC processes. However, not all aspects of the design are commercially available.

In addition, the cross heat exchanger module will consist of a further module based upon two concepts. The first concept is a moving bed plate and frame heat exchanger which transfers sensible heat from the hot CO₂ lean sorbent to cold CO₂ rich sorbent via a working fluid within the plates. As the sorbent flows between the plates heat is either transferred from hot sorbent to cool plates and the working fluid in the plates or cool sorbent flows past plates being warmed by the hot heat transfer fluid circulating within the plates.

The second concept uses a fluidized bed system with heat exchanger coils to extract heat from the hot CO₂ lean sorbent and transfer heat to the cold CO₂ rich sorbent. This system is analogous to a shell and tube heat exchanger where the fluidized sorbent in a vessel flows past coils with a heat transfer fluid circulating through the coils. The sensible heat of the hot CO₂ lean sorbent is then rejected to the heat transfer fluid in the coils which then is used in another exchanger to heat the cool CO₂ rich sorbent before it enters the regenerator.

technology advantages

- Sensible heat recovery.
- Reduced adsorber pressure drop.
 - Sorbent is currently cooled in top adsorber bed.
 - Reduced cooling requirements, smaller bed, reduced flue gas blower power, and reduced thermal regeneration input and cooling duty.
- Reduced regenerator pressure drop.
 - Sorbent enters regenerator at higher temperature.
 - Less heat transfer surface required.

R&D challenges

- Benefits of heat recovery must outweigh the increase in capital costs.
- The addition of a cross-heat exchanger may increase the footprint of the existing capture unit.
 - For many existing power plants, overall site footprint may be a limiting factor.
- A heat exchanger will necessitate more sorbent residence time and increase the amount of sorbent required for the process.
- Sorbent cycling time flexibility will be limited by heat exchange requirements.

results to date/accomplishments

- Model runs have been conducted using available sorbent and process parameters to assist in planning for the bench-scale tests.
- A single heat exchanger concept and integration scheme has been identified and has entered the process design phase.
- Building of an ASPEN Plus model of the sorbent capture process is underway.

next steps

- Develop a working understanding of sorbent desorption behavior in the heat exchanger.
 - Determine the gas handling requirements of desorbed gas in the heat exchanger.
- Develop commercial design of both heat exchanger concepts.
- Apply commercial designs from Technip and Solex to Lehigh's process model.
 - Assess the maximum process and cost benefits of various heat exchanger designs and approach temperatures.

available reports/technical papers/presentations

Sjostrom, S. and Morris, W., "Optimizing the Costs of Solid Sorbent-Based CO₂ Capture Process through Heat Integration," 2014 NETL CO₂ Capture Technology Meeting, Pittsburgh, PA, July 2014.

<http://www.netl.doe.gov/File%20Library/Events/2014/2014%20NETL%20CO2%20Capture/S-Sjostrom-ADA-Optimizing-the-Costs-of-Solid-Sorbent-Based-CO2.pdf>.

Sjostrom, S., "Optimizing the Costs of Solid Sorbent-Based CO₂ Capture Process through Heat Integration," Project Kick Off Meeting, Pittsburgh, PA, November 2013. <http://www.netl.doe.gov/File%20Library/Research/Coal/ewr/CO2/NETL-ADA-Heat-Integration-Project-Kickoff-Meeting.pdf>.

BENCH-SCALE DEVELOPMENT AND TESTING OF A NOVEL ADSORPTION PROCESS FOR POST-COMBUSTION CO₂ CAPTURE

primary project goals

InnoSeptra, LLC is developing a sorption-based technology using a combination of novel microporous materials and process cycles to determine the impacts of this unique combination on capture costs and performance via bench-scale testing of system components using actual coal-based flue gas.

technical goals

- Confirm the design basis for bench-scale testing based on lab-scale results and process modeling.
- Build and mechanically test the bench-scale unit in the lab.
- Test the bench-scale unit on an actual coal-based flue gas stream for a period of 6–8 weeks.
- Develop capital cost, operating cost, and leveled cost of electricity (LCOE) estimates for a commercial, 550-MW power plant.

technical content

InnoSeptra is demonstrating the effectiveness of an innovative, adsorption-based carbon dioxide (CO₂) capture technology utilizing a combination of novel microporous materials and process cycles. The process utilizes physical sorbents with much lower heats of adsorption (around 38 kJ/mol, less than 25 percent of the total energy needed for amine-based systems) compared to competing processes. Bench-scale testing has produced greater than 99 percent CO₂ purity and greater than 90 percent CO₂ recovery from the actual coal-fired plant flue gas. Projections based on detailed engineering evaluations show that at commercial scale, the technology can reduce the power consumption for CO₂ capture by more than 40 percent, and reduce the capital cost for the CO₂ capture equipment by more than 40 percent; this results in a more than 40 percent reduction in the CO₂ capture cost compared to alternate technologies such as amines and chilled ammonia. The overall process schematic is shown in Figure 1.

technology maturity:

Bench-Scale, Actual Flue Gas

project focus:

Novel Adsorption Process

participant:

InnoSeptra, LLC

project number:

FE0007948

NETL project manager:

Elaine Everitt
elaine.everitt@netl.doe.gov

principal investigator:

Ravi Jain InnoSeptra, LLC
ravi.jain@innosepra.com

partners:

Adsorptech
New Mexico State
University
Electric Power Research
Institute
NRG Energy, Inc.
Pacific Northwest
National Laboratory

performance period:

10/1/11 – 3/31/15

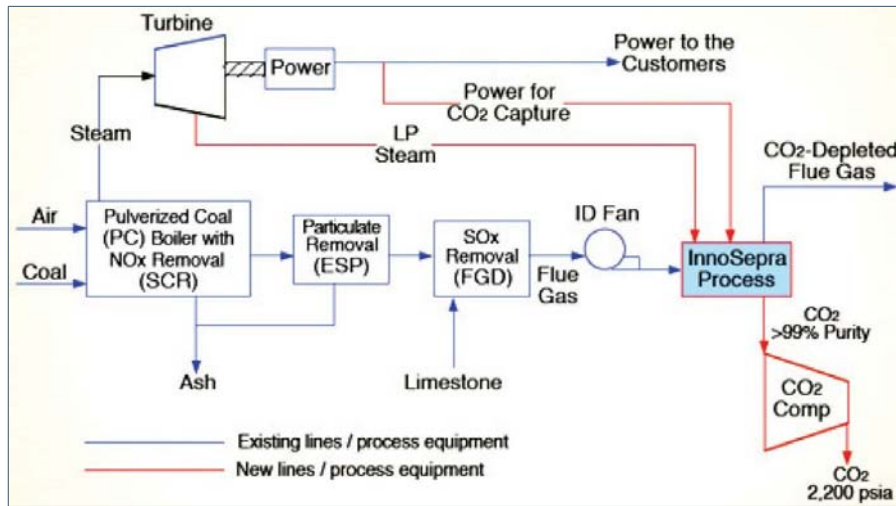

Figure 1: InnoSeptra Capture Process Schematic

Figure 2 provides a schematic representation focusing on the CO₂ removal process. After the removal of moisture and sulfur oxides (SO_x) in a pretreatment system, the CO₂ is captured in an adsorber, and then high-purity CO₂ is produced during sorbent regeneration. The sorbents are heated and cooled using both direct and indirect cooling. Some of the heat of adsorption is removed during the adsorption process; the remaining heat is removed during the cooling steps. Regeneration heat is supplied via low-pressure steam, as well as by utilizing other process waste heat in the system.

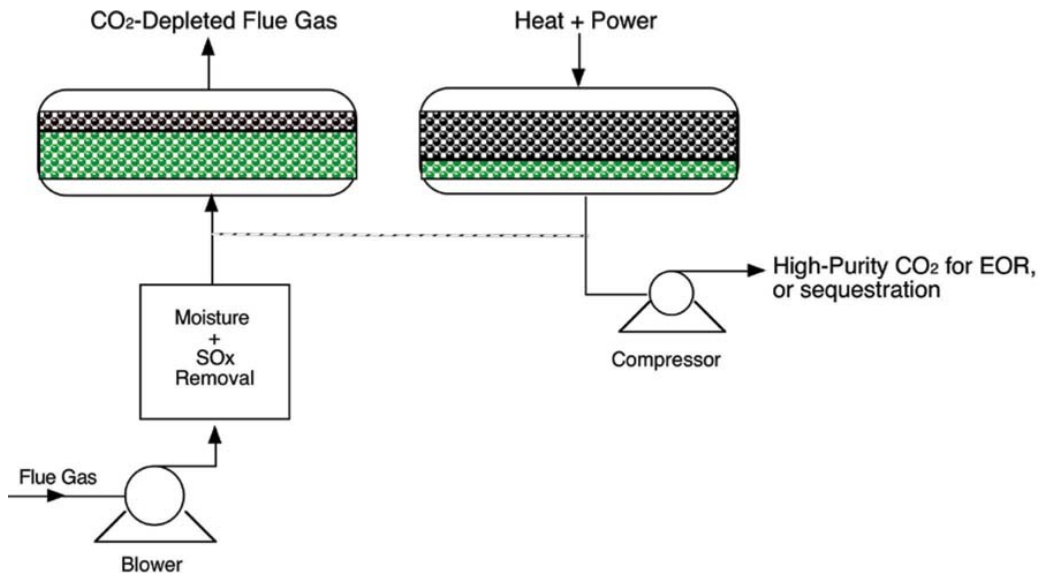

Figure 2: CO₂ Capture Process Schematic

Field-testing of the process at a 1-ton-per-day scale in an actual power plant, as well as independent verification of process economics, has provided a firmer basis for techno-economic evaluation. This technology has the potential for earlier commercialization compared to some other technologies because most of the materials and unit operations used are commercial or near-commercial.

TABLE 1: ADSORPTION-BASED POST-COMBUSTION CO₂/N₂ SEPARATIONS

	Units	Current R&D Value	Target R&D Value
Sorbent			
True Density at STP	kg/m ³	1,990	1,990
Bulk Density	kg/m ³	690	690
Average Particle Diameter	mm	1.5–3.0	0.5–1.5
Particle Void Fraction	m ³ /m ³	0.45	0.45
Packing Density	m ² /m ³	1.79e8	1.79e8
Solid Heat Capacity at STP	kJ/kg-K	0.96	0.96
Crush Strength	kgf	2.9	2.9
Manufacturing Cost for Sorbent	\$/kg	4.0	3.0–4.0
Adsorption			
Pressure	bar	1.15	1.1
Temperature	°C	25–32	25–32
Equilibrium CO ₂ Loading	g mol CO ₂ /kg	3.25	3.5–4.0
Heat of Adsorption	kJ/mol CO ₂	38	38
Desorption			
Pressure	bar	0.3–1.0	0.3–1.0
Temperature	°C	100	90–110
Equilibrium CO ₂ Loading	g mol CO ₂ /kg	1.5	0.5–1.5
Heat of Desorption	kJ/mol CO ₂	38	38
Proposed Module Design		<i>(for equipment developers)</i>	
Flow Arrangement/Operation	—	fixed/cyclic	fixed/cyclic
Flue Gas Flowrate	kg/hr	2,320,000	2,320,000
CO ₂ Recovery, Purity, and Pressure	%/%/bar	90%, 99%, 1.0 bar	
Adsorber Pressure Drop	bar	0.14	0.10

Definitions:

STP – Standard Temperature and Pressure (15 °C, 1 atm).

Sorbent – Adsorbate-free (i.e., CO₂-free) and dry material as used in adsorption/desorption cycle.

Manufacturing Cost for Sorbent – “Current” is market price of material, if applicable; “Target” is estimated manufacturing cost for new materials, or the estimated cost of bulk manufacturing for existing materials.

Adsorption – The conditions of interest for adsorption are those that prevail at maximum sorbent loading, which typically occurs at the bottom of the adsorption column. These may be assumed to be 1 atm total flue-gas pressure (corresponding to a CO₂ partial pressure of 0.13 bar) and 40 °C; however, measured data at other conditions are preferable to estimated data.

Desorption – The conditions of interest for desorption are those that prevail at minimum sorbent loading, which typically occurs at the bottom of the desorption column. Operating pressure and temperature for the desorber/stripper are process-dependent. Measured data at other conditions are preferable to estimated data.

Pressure – The pressure of CO₂ in equilibrium with the sorbent. If the vapor phase is pure CO₂, this is the total pressure; if it is a mixture of gases, this is the partial pressure of CO₂. Note that for a typical pulverized coal (PC) power plant, the total pressure of the flue gas is about 1 atm and the concentration of CO₂ is about 13.2 percent. Therefore, the partial pressure of CO₂ is roughly 0.132 atm or 0.130 bar.

Packing Density – Ratio of the active sorbent area to the bulk sorbent volume.

Loading – The basis for CO₂ loadings is mass of dry, adsorbate-free sorbent.

Flow Arrangement/Operation – Gas-solid module designs include fixed, fluidized, and moving bed, which result in either continuous, cyclic, or semi-regenerative operation.

Estimated Cost – Basis is kg/hr of CO₂ in CO₂-rich product gas; assuming targets are met.

Other Parameter Descriptions:

Chemical/Physical Sorbent Mechanism – The adsorption is physical sorption based on weak van der Waals forces. This leads to low heats of adsorption.

Sorbent Attrition and Thermal/Hydrothermal Stability – The process design protects the adsorbent from moisture and potential hydrothermal degradation. If moisture should breakthrough onto the adsorbent, the adsorbent can be regenerated completely. The adsorbent is thermally stable at temperatures of more than 300 °C.

Sorbent Makeup Requirements – Based on prior experience with similar sorbents in similar operating environments, the adsorbent life would be between 5 and 10 years. An adsorbent life of 5 years has been assumed to estimate the makeup requirements.

Waste Streams Generated – Except for the sorbents loaded with flue gas components, SO_x and mercury, no other waste streams are generated in the process. These can be disposed of as per current power plant practices for materials loaded with SO_x and Hg.

Proposed Module Design – The CO₂ capture modules will be designed to capture CO₂ from a 550-MW PC power plant. Multiple modules will be used to minimize field fabrication and maximize offsite fabrication. The separation skid will consist of a feed preparation section (flue gas compression and cooling), the CO₂ adsorption section (removal of impurities, CO₂ adsorption, and desorption), and the CO₂ compression section. Unless noted, flue gas feed pressure is 1.014 bar, temperature is 57 °C, and composition leaving the flue gas desulfurization (FGD) unit (wet basis) should be assumed as indicated in the Table below:

Composition (% vol)					Composition (ppmv)	
CO ₂	H ₂ O	N ₂	O ₂	Ar	SO _x	NO _x
13.17	17.25	66.44	2.34	0.8	42	74

technology advantages

- The technology is able to utilize physical sorbents to obtain the same purity and recovery as chemical sorbents and amine- based absorption.
- The sorbents have lower heats of adsorption compared to reaction-based systems.
- The technology is able to produce >99 percent CO₂ at >90 percent recovery with an energy penalty of less than 60 percent of the energy penalty for the monoethanolamine (MEA) systems.
- The process is non-corrosive and can utilize carbon steel construction for the most part.

R&D challenges

- Heat management during both adsorption and regeneration.
- Water management.

results to date/accomplishments

- Two adsorbents with a CO₂ capacity greater than 5 wt% in cyclic steady state experiments have been identified.
- Adsorption and desorption isotherms, as well as the kinetic data for these adsorbents, have been measured.
- The heat and mass transfer data have been measured with different diameter beds (0.75–1.5 inch), and a preliminary design of the bench-scale unit for field-testing has been completed.
- Methods to remove contaminants such as nitrogen oxide (NO_x) and SO_x have been tested.
- A rigorous process model of the adsorption process has been developed, tested, and updated.
- A preliminary technical and economic feasibility study of the process has been completed. The projected increase in LCOE is less than 45 percent, and the projected CO₂ capture cost is about \$40/tonne.
- A preliminary design and costing of a process unit capable of producing about one ton per day of CO₂ from flue gas was completed.
- Detailed mechanical design of the bench-scale test unit was completed and the components were procured.
- Field demonstration of the bench-scale unit was conducted at NRG's Indian River power plant.
- Analysis of the used sorbents was performed.
- An EH&S (Environmental, Health & Safety) report was completed.
- A techno-economic analysis based on the lab and field data, process simulation and detailed engineering design indicates the potential for a CO₂ capture cost below \$45/tonne.

next steps

- This project ended March 31, 2015.

available reports/technical papers/presentations

Jain, R., "Bench-Scale Development and Testing of a Novel Adsorption Process for Post-Combustion CO₂ Capture," presented at the 2014 NETL CO₂ Capture Technology Meeting, Pittsburgh, PA, July 2014.

<http://www.netl.doe.gov/File%20Library/Events/2014/2014%20NETL%20CO2%20Capture/R-Jain-InnoSeptra-Bench-Scale-Development-And-Testing.pdf>.

Jain, R., "Bench-Scale Development and Testing of a Novel Adsorption Process for Post-Combustion CO₂ Capture," presented at the 2013 NETL CO₂ Capture Technology Meeting, Pittsburgh, PA, July 2013.

<http://www.netl.doe.gov/File%20Library/Events/2013/CO2%20Capture/R-Jain-Innosepra-Novel-Adsorption-Process.pdf>.

Jain, R., "Bench-Scale Development and Testing of a Novel Adsorption Process for Post-Combustion CO₂ Capture," presented at the 2012 NETL CO₂ Capture Technology Meeting, Pittsburgh, PA, July 2012. <http://www.netl.doe.gov/publications/proceedings/12/CO2capture/presentations/2-Tuesday/R%20Jain-InnoSeptra-Adsorption%20Process.pdf>.

RAPID TEMPERATURE SWING ADSORPTION USING POLYMERIC/SUPPORTED AMINE HOLLOW FIBER MATERIALS

primary project goals

The Georgia Institute of Technology is developing a rapid temperature swing adsorption (RTSA) process and will evaluate the cost and performance benefits of this novel hybrid capture approach via bench-scale testing of a module containing hollow fibers, which are loaded with supported adsorbents and surround an impermeable lumen layer that allows for cooling and heating.

technical goals

- Produce polymeric hollow fiber contactors loaded with amine adsorbent particles for post-combustion carbon dioxide (CO₂) capture.
- Develop a computational model of the fiber module and validate it in parallel with the experimental program.

technical content

Supported amine adsorbents have many promising properties with regard to CO₂ capture from post-combustion flue gas. However, most previous studies of supported amine materials focus only on CO₂ adsorption, ignoring desorption. In addition, essentially all published studies describe the use of supported amine materials in fixed beds. This process configuration is difficult to use at practical scales due to heat integration challenges. This is especially important for supported amines, whose heats of adsorption are among the highest of known CO₂ adsorbents (50–80 kJ/mol). Thus, practical process designs for amine sorbents must include effective heat transfer.

Recently, the use of novel polymeric hollow fiber contactors loaded with CO₂ adsorbents has been introduced as a scalable process configuration for CO₂ capture. In this approach, polymeric hollow fibers, similar to those used for commercial-scale membrane gas separation, are prepared and loaded with large volumes of solid CO₂ adsorbing materials. However, unlike those used for membrane applications, these hollow fibers have several unique aspects. First, high volumes of adsorbent materials are included, typically 60–75 percent by volume. Second, the polymeric phase is designed to have many large voids, allowing rapid mass transfer to the sorbent particles. Third, a dense lumen layer is installed in the fiber bore to largely shutdown transport from the shell side of the fibers to the bore. This design yields fibrous structures that are ideally suited for application as combined sorption and heat transfer modules in an RTSA process. Total cycle times are expected to be on the order of 2–3 minutes.

technology maturity:

Bench-Scale, Simulated Flue Gas

project focus:

Rapid Temperature Swing Adsorption

participant:

The Georgia Institute of Technology

project number:

FE0007804

NETL project manager:

Bruce Lani
bruce.lani@netl.doe.gov

principal investigator:

Christopher W. Jones
Georgia Institute of Technology
christopher.jones@chbe.gatech.edu

partners:

Trimeric Corporation,
Algenol Biofuels,
Southern Company
Services,
GE Energy

performance period:

10/1/11 – 3/31/15

In the amine-hollow-fiber RTSA process, flue gases flow over the shell of the fibers while cooling water flows through the bore. Given the small diameter of the fibers, the fibers and adsorbents can be maintained in nearly isothermal conditions, with the cooling fluid providing an effective reservoir for heat of adsorption (Figure 1). At the appropriate time, the flue gas can be rerouted to another bed and the fibers can be switched to desorption mode by passing hot water through the fiber bore, driving off the CO₂.

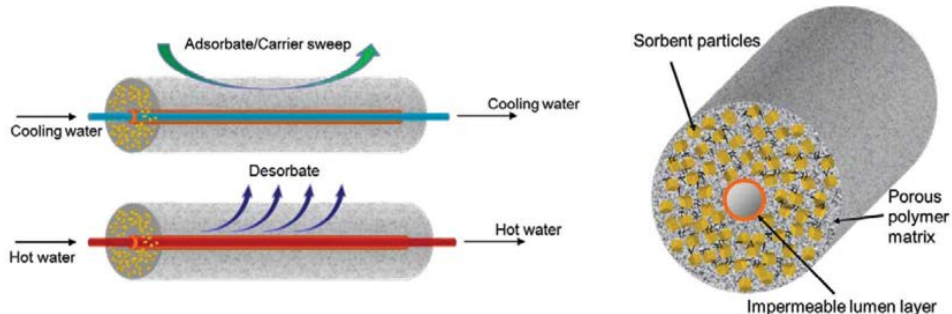

Figure 1: Sorption (top) and Desorption (bottom) Modes in Hollow Fiber Sorbents

This RTSA approach was recently demonstrated using cellulose acetate fibers and zeolite 13X as the adsorbent in the fibers. Zeolite 13X is not an ideal sorbent for wet post-combustion CO₂ capture streams, but supported amines may be well suited for the task.

The hollow fiber architecture has three key attributes: (1) it provides the adsorption surface area needed to handle large volumes of flue gas, (2) it enables efficient heat transfer needed to handle the high heat of adsorption of supported amines, and (3) it is readily scalable given the current commercial capability to produce large surface area hollow fibers on an industrial scale.

The RTSA process based on hollow fibers containing supported amine adsorbents represents a novel new process configuration for post-combustion CO₂ capture. In a commercial process, multiple hollow fiber modules would be used, and modules would cycle synergistically between adsorption and desorption modes in a continuous process, as shown in Figure 2.

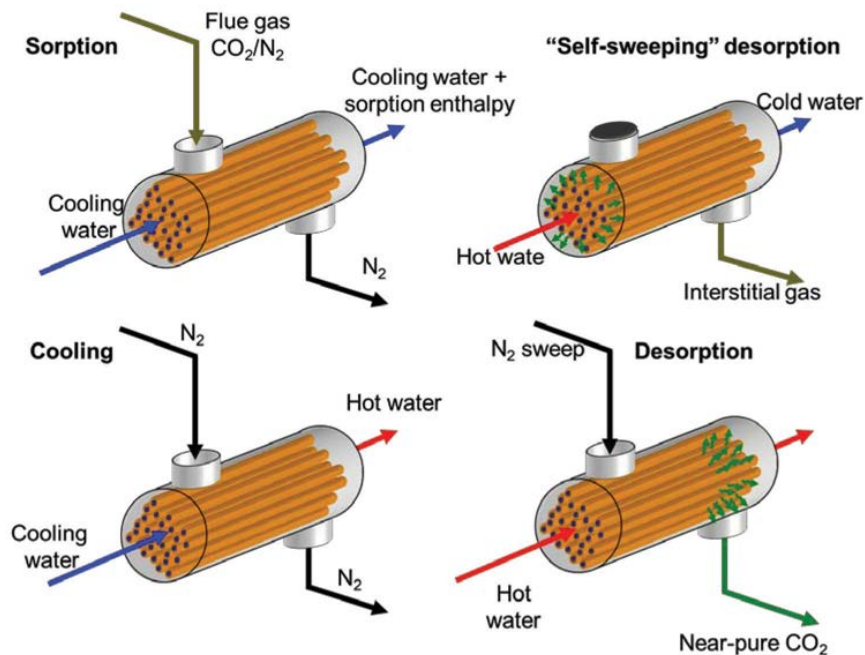

Figure 2: Potential RTSA Process Configuration

TABLE 1: ADSORPTION-BASED POST-COMBUSTION CO₂/N₂ SEPARATIONS

	Units	Current R&D Value	Target R&D Value
Sorbent			
True Density at STP	kg/m ³	1,100	1,100
Bulk Density	kg/m ³	1,100	1,100
Average Particle ¹ Diameter	mm	1.2	1.0
Particle Void Fraction	m ³ /m ³	0.4–0.5	0.28–0.3
Packing Density	m ² /m ³	0.44	0.4–0.5
Solid Heat Capacity at STP	kJ/kg-K	1,800	3,000
Crush Strength	kgf	1.140	1.140
Manufacturing Cost for Sorbent	\$/kg	unknown	unknown
Manufacturing Cost for Fiber Module (includes hardware, fibers, sorbent)	\$/kg	unknown	\$10/m ² or \$25–\$35/kg
Adsorption			
CO ₂ Partial Pressure	bar	0.159	0.13
Temperature	°C	55	35
Equilibrium CO ₂ Loading	g mol CO ₂ /kgfiber	0.84	1.0–1.5
Heat of Absorption	kJ/mol CO ₂	59	55–65
Desorption			
Pressure	bar	0.2	5.5
Temperature	°C	120	90
Equilibrium CO ₂ Loading	g mol CO ₂ /kgfiber	0.34	0.1
Heat of Desorption	kJ/mol CO ₂	59	55–65
Proposed Module Design		<i>(for equipment developers)</i>	
Flow Arrangement/Operation	—	co-current shell and tube	co-current shell and tube
Flue Gas Flowrate	kg/hr	200 sccm (lab), ≈2,900 (full scale, per module)	0.5 (lab), ≈2,900 (full scale, per module)
CO ₂ Recovery, Purity, and Pressure	%/%/bar	91% R, 96 mol%, 0.2 bar (0.19 bar partial pressure)	90% R, 95 mol%, at 1 bar or 80 mol% at 5.5 bar
Adsorber Pressure Drop	bar	<0.1	<0.15

Definitions:

STP – Standard Temperature and Pressure (15 °C, 1 atm).

Sorbent – Adsorbate-free (i.e., CO₂-free) and dry material as used in adsorption/desorption cycle.

Fiber Bundle – collection of fibers to be used in a single module. Each fiber contains 50–55 percent weight solid sorbent, and 30–50 percent of the solid sorbent is amine.

Manufacturing Cost for Sorbent – “Current” is market price of material, if applicable; “Target” is estimated manufacturing cost for new materials, or the estimated cost of bulk manufacturing for existing materials.

Adsorption – The conditions of interest for adsorption are those that prevail at maximum sorbent loading, which typically occurs at the bottom of the adsorption column. These may be assumed to be 1 atm total flue-gas pressure (corresponding to a CO₂ partial pressure of 0.13 bar) and 40 °C; however, measured data at other conditions are preferable to estimated data.

¹ Particle here refers to the hollow fiber

Desorption – The conditions of interest for desorption are those that prevail at minimum sorbent loading, which typically occurs at the bottom of the desorption column. Operating pressure and temperature for the desorber/stripper are process-dependent. Measured data at other conditions are preferable to estimated data.

Pressure – The pressure of CO₂ in equilibrium with the sorbent. If the vapor phase is pure CO₂, this is the total pressure; if it is a mixture of gases, this is the partial pressure of CO₂. Note that for a typical PC power plant, the total pressure of the flue gas is about 1 atm and the concentration of CO₂ is about 13.2 percent. Therefore, the partial pressure of CO₂ is roughly 0.132 atm or 0.130 bar.

Packing Density – Ratio of the active sorbent area to the bulk sorbent volume.

Loading – The basis for CO₂ loadings is mass of dry, adsorbate-free sorbent.

Flow Arrangement/Operation – Gas-solid module designs include fixed, fluidized, and moving bed, which result in either continuous, cyclic, or semi-regenerative operation.

Other Parameter Descriptions:

Chemical/Physical Sorbent Mechanism – The underlying mechanism is primary and secondary amines reacting with CO₂ to produce carbamates or (bi)carbonates, depending on the nature of the amines, amine loading, and humidity level. Under most conditions, a mixture of species is formed on the adsorbent surface.

Sorbent Contaminant Resistance – Thus far, the solid supported amines developed for this project have displayed excellent oxidative stability, stability in humid conditions (5–90 percent RH), and resistance to nitric oxide. The active amine fillers are poisoned by high concentrations of sulfur oxide (SO_x, 200 parts per million [ppm]), and extensive sulfur removal is needed.

Sorbent Attrition and Thermal/Hydrothermal Stability – Due to the sorbents being “protected” within the walls of the hollow fiber sorbents, the Georgia Institute of Technology has yet to experience any mechanical issues (such as attrition) in their studies. The fibers themselves are quite temperature-resistant, but the amines have a realistic upper temperature limit of ≈130 °C. The fibers can restructure upon extended exposure to high humidity at high temperature. However, the water sorption capacity of the fibers is much higher than the CO₂ capacity, so CO₂ breakthrough occurs while the majority of the fiber is still dry. Therefore, degradation due to humidity can be controlled.

Flue Gas Pretreatment Requirements – Current analysis indicates that flue gas cooling to approximately 35 °C is required for low-cost CO₂ capture. Experimental work suggests that partial dehydration of the flue gas may prolong fiber lifetimes (i.e., 90 percent RH vs. 100 percent RH). Finally, further wet flue gas desulfurization (FGD) may be required for additional SO_x removal for optimum long-term performance of the amines.

Sorbent Makeup Requirements – Analyses investigating the amine loss mechanism and rate are ongoing.

Waste Streams Generated – Spent fiber sorbents represent the only process waste stream. Currently, the fibers are assumed to last 3 years before replacement is required.

Process Design Concept – See Figure 3.

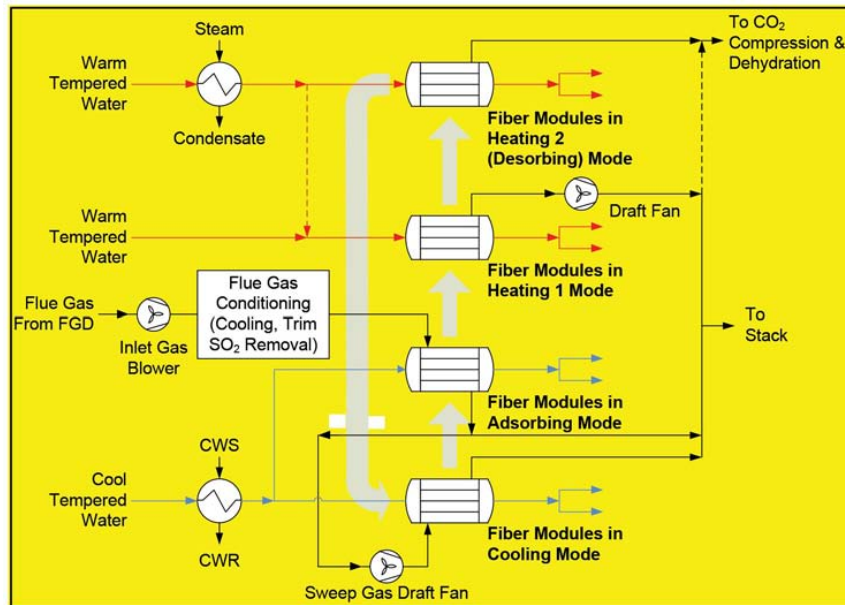

Figure 3: Flowsheet/Block Flow Diagram

Proposed Module Design – Note the module location, as well as the pressure, temperature, and composition of the gas entering the module. Unless noted, flue gas feed pressure is 1.014 bara, temperature is 57 °C, and composition leaving the FGD unit (wet basis) should be assumed:

Composition (% vol)					Composition (ppmv)	
CO ₂	H ₂ O	N ₂	O ₂	Ar	SO _x	NO _x
13.17	17.25	66.44	2.34	0.8	42	74

Several shell-and-tube hollow fiber sorbent modules are being considered. In this arrangement, the flue gas is sent through a valve manifold “cascade” that introduces the flue gas sequentially into the “rack” of modules. A similar approach is envisioned for water that will be valved and pumped through the bore side of the hollow fiber sorbents to enable rapid heating and cooling, thus driving down system footprint and increasing the overall sorbent productivity. The flue gas will enter through a gas diffuser ring at the “top” of the shell side of the module. The gas will proceed through the shell side until CO₂ breaks through the “bottom” of the module; the tightly packed hollow fibers prevent gas bypass. Water will enter the bore side of the fibers through a header system and will flow in the same directions as the flue gas (co-current design). The water eluent is segregated based on temperature and is recycled throughout the process in a tempered water system, which facilitates intra-process heat recovery.

technology advantages

- Deleterious thermal effects typically associated with packed-bed sorption can be mitigated and higher sorption efficiencies can be achieved by utilizing the hollow fiber morphology to supply cooling agents in the bore of the fiber during adsorption.
- The thin porous walls of the fiber sorbent allow for rapid heat and mass transfer equilibration, thereby allowing for more rapid thermal cycles and thus reducing device volume.
- Pressure drops through these beds will be correspondingly lower than those of packed or fluidized solid sorbent beds, which will reduce draft fan costs.
- Heat transfer fluids in the bore of the fibers can be as simple as hot water and cold water, providing an environmentally friendly overall process.

- Rapid heat transfer enables potential recovery of heat of adsorption and reuse of sensible heat of the bed. This affords heat integration both within the capture process and may facilitate heat integration with the boiler feed water preheat. This can dramatically reduce the overall parasitic thermal load of the RTSA process.

R&D challenges

- High heat of adsorption, with heat management improved by contactor design.
- Deactivation of sorbents upon exposure to oxygen, SO_x, and exposure to saturated humidity and temperature.
- Low-working capacity in more conventional contactors.
- Efficient heat integration with power plant

results to date/accomplishments

- Fibers and amine/silica sorbents synthesized.
- New, scalable amine/sorbent/fiber synthesis protocol developed.
- Construction and operation of RTSA Testing Station 1 for CO₂ uptake experiments and pressure-drop measurements.
- First demonstration of CO₂ capture from amine containing hollow fibers in small modules.
- Demonstration of resistance to O₂ and nitric oxide under conditions typical of flue gas.
- Demonstrated capture of 70% of sorption enthalpy released during adsorption of CO₂ (essentially isothermal operation).
- Performed RTSA experiments in both dry and wet flue gas conditions.
- Tested and verified cyclic stability of breakthrough capacity in hollow fibers for over 120 cycles.
- Novel lumen-side dual-layer hollow fiber spinning technique developed for scalable production of bore-side barrier layers in hollow fiber sorbents.
- Demonstrated reusability of fibers by recharging deactivated fibers with fresh amines, which returned the module to its original breakthrough CO₂ capacity.
- Models of adsorption-heating-desorption-cooling cycle developed that captures temperature dependent mass transfer dynamics and breakthrough capacity of amine adsorbent.
- Rigorously validated model under varied operating conditions and design conditions such as fiber length, packing fraction and sorbent particle size.
- Detailed analysis of mass and heat transfer sorption kinetics using experimental data and validated model.
- Bench-scale modules constructed and tested (0.5' x 3' 150 fibers) for RTSA Testing Station 2 to do heat transfer measurements.
- Optimized sorbent, fiber, and module parameters to maximize heat recovery.
- Optimized cycle operating conditions such as gas and cooling water flow rates and cycle time to minimize cost per ton of CO₂ captured.
- Performed a detailed techno economic evaluation of process with experimentally validated model and optimized parameters.
- Performed EH&S assessment of RTSA technology and evaluated risks associated with process.
- Demonstrated that RTSA process for CO₂ capture is feasible within purity, recovery and cost constraints set by DOE.

next steps

This project ended on March 31, 2015.

[available reports/technical papers/presentations](#)

Reports and Presentations

Jones, C, et al., “Rapid Temperature Swing Adsorption Using Polymer/Supported Amine Composite Hollow Fibers,” presented at the 2014 NETL CO₂ Capture Technology Meeting, Pittsburgh, PA, July 2014.
<http://www.netl.doe.gov/File%20Library/Events/2014/2014%20NETL%20CO2%20Capture/C-Jones-GIT-Rapid-Temperature-Swing-Adsorption.pdf>.

Jones, C., et al., “Rapid Temperature Swing Adsorption Using Polymer/Supported Amine Composite Hollow Fibers,” presented at the 2013 NETL CO₂ Capture Technology Meeting, Pittsburgh, PA, July 2013.
<http://www.netl.doe.gov/File%20Library/Events/2013/CO2%20Capture/C-Jones-GTech-Rapid-TSA-using-Amine-Hollow-Fibers.pdf>.

Reaff, M, et al., “Rapid Temperature Swing Adsorption Using Polymer/Supported Amine Composite Hollow Fibers,” presented at the 2012 NETL CO₂ Capture Technology Meeting, Pittsburgh, PA, July 2012.

Lively, R., “Hollow Fiber Sorbents for Post-Combustion CO₂ Capture,” dissertation, Georgia Institute of Technology, January 2011.

Labreche, Y, et al., “Post-Spinning Infusion of Poly(ethyleneimine) into Polymer/Silica Hollow Fiber Sorbents for Carbon Dioxide Capture,” *Chemical Engineering Journal*, Volume 221, 1 April 2013, Pages 166–175.

Publications

Labreche, Y, et al., *Post-spinning infusion of poly(ethyleneimine) into polymer/silica hollow fiber sorbents for carbon dioxide capture*. *Chemical Engineering Journal*, 2013, 221, 166-175.

Rezaei, F, et al., *Aminosilane-grafted polymer/silica hollow fiber adsorbents for CO₂ capture from flue gas*. *ACS Applied Materials & Interfaces*, 2013, 5, 3921-3931.

Rezaei, F, et al., *Stability of Supported Amine Adsorbents to SO₂ and NO_x in Post-Combustion CO₂ Capture Process-I. Single Component Adsorption*. *Industrial & Engineering Chemistry Research*, 2013, 52, 12192-12201.

Fan, Y, et al., *Evaluating CO₂ dynamic adsorption performance of polymer/silica supported poly(ethyleneimine) hollow fiber sorbents in rapid temperature swing adsorption*. *International Journal of Greenhouse Gas Control*, 2014, 21, 61-71.

Labreche, Y, et al., *Poly (amide-imide)/Silica Supported PEI Hollow Fiber Sorbents for Postcombustion CO₂ Capture by RTSA*. *ACS Appl. Mater. Interfaces*, 2014, 6, 19336-19346.

Rezaei, F, Jones, C, *Stability of Supported Amine Adsorbents to SO₂ and NO_x in Post-Combustion CO₂ Capture Process-2. Multicomponent Adsorption*. *Industrial & Engineering Chemistry Research*, 2014, 53, 12103-12110.

Fan, Y, et al., *Dynamic CO₂ Adsorption Performance of Internally Cooled Silica Supported Poly(ethyleneimine) Hollow Fiber Sorbents*. *AIChE J.*, 2014, 60, 3878-3887.

Rezaei, F, et al., *Modelling of Rapid Temperature Swing Adsorption Using Hollow Fiber Sorbents*. *Chem. Eng. Sci.*, 2014, 113, 62-67.

Kalyanaraman, J, et al., *Modelling and Experimental Validation of Carbon Dioxide Sorption on Hollow Fibers Loaded with Silica-Supported Poly(ethyleneimine)*. *Chem. Eng. J.*, 2015, 259, 737-751.

Labreche, Y, et al., *Direct Dual Layer Spinning of Aminosilica/Torlon® Hollow Fiber Sorbents with a Lumen Layer for CO₂ Separation by Rapid Temperature Swing Adsorption*. *J. Appl. Polym. Sci.*, 2015, 132, 4185.

Fan, Y, et al., *CO₂ Sorption Performance of Composite Polymer/Aminosilica Hollow Fiber Sorbents*. *Ind. Eng. Chem. Res.*, 2015, 54, 1783-1795.

Swernath, S, et al., *Optimization and Techno-Economic Analysis of Rapid Temperature Swing Adsorption (RTSA) Process for Carbon Capture from Coal-Fired Power Plant*. *Comput. Aided Chem. Eng.*, 2015, in press.

Kalyanaraman, J, et al., *Bayesian estimation of parametric uncertainties, quantification and reduction using optimal design of experiments for CO₂ adsorption on amine sorbents*. *Comput. Chem, Eng.* (Submitted 11/5/2014, in revision).

Fan, Y, et al., *Stability of Amine-based Hollow Fiber CO₂ Adsorbents to NO and SO₂*. *Fuel*, to be submitted 04/15.

Inventions

"Dual Layer Spinning with Lumen Layer PAI Polymer/Silica/PEI Hollow Fiber Sorbent for RTSA" submitted on 11/25/2013, Labreche, Y, Koros, W.J, Lively, R. P.

"Novel Amine Post-Spinning Infused Polymer/Silica Composite Hollow Fiber Sorbents" submitted on 07/18/2012. Labreche, Y, Koros, W.J, Lively, R. P, Rezaei, F, Chen, G, Jones, C. W, Sholl, D. S.

EVALUATION OF CARBON DIOXIDE CAPTURE FROM EXISTING COAL-FIRED PLANTS BY HYBRID SORPTION USING SOLID SORBENTS

primary project goals

The University of North Dakota (UND) and Envergex LLC are developing a solid sorbent technology—Capture from Existing Coal-Fired Plants by Hybrid Sorption (CACHYS™)—that is based on the following principles:

- Reduction of energy for sorbent regeneration.
- Utilization of novel process chemistry.
- Contactor conditions that minimize sorbent-CO₂ heat of reaction and promote fast CO₂ capture.
- Low-cost method of heat management.
- Low-cost, carbon-based sorbent impregnated with an alkali carbonate salt and an active promoter.

technical goals

- Sorbent selection and formulation, as well as the determination of heat of sorption, sorbent capacity (CO₂ loading), and sorbent physical properties for process design definition.
- Conduct lab-scale, fixed-bed tests to investigate adsorption and desorption kinetics, working capacity, heats of adsorption and desorption and a relative measure of attrition during multiple cycles.
- Establish the optimum process conditions (e.g., temperatures, pressures, and residence times), preferred sorbent compositions, and bench-scale equipment design (e.g., size, energy duties, and material feed rates).
- Design, build, and operate a bench-scale CACHYS™ adsorption and desorption system designed for a flue gas flow rate of 30 actual cubic feet per minute (acfm) obtained as a slipstream from a sub-bituminous coal-fired stoker boiler at the UND campus steam plant.

technical content

The project was intent on developing key information for the CACHYS™ process - sorbent performance, energy for sorbent regeneration, physical properties of the sorbent, the integration of process components, sizing of equipment, and overall capital and operational cost of the integrated CACHYS™ system. The bench-scale CACHYS™ test unit includes a flue gas conditioning system to remove particulate matter and sulfur dioxide via a fabric filter and a wet packed-bed scrubber using sodium hydroxide solution, respectively. Two circulating fluidized beds are employed for CO₂ adsorption. The Solex Thermal regenerator system consists of three functional units capable of operating at elevated pressure—the

technology maturity:

Bench-Scale, Actual Flue Gas

project focus:

Solid Sorbent-Based CO₂ Capture

participant:

University of North Dakota

project number:

FE0007603

NETL project manager:

Andrew Jones
andrew.jones@netl.doe.gov

principal investigator:

Steven A. Benson
University of North Dakota
steve.benson@enr.und.edu

partners:

Industrial Commission of North Dakota
Envergex LLC
Barr Engineering
Solex Thermal Science Incorporated
ALLETE Incorporated
SaskPower

performance period:

10/1/11 – 12/31/14

preheater, the regenerator, and the cooler. Sorbent transferred from the adsorber system is heated to the desired regeneration temperature in the preheater and transferred to the regenerator unit where the CO₂ is desorbed from the sorbent. The sorbent then transfers to the cooler, where the temperature of the sorbent is returned to the adsorption temperature. The sorbent is then transferred back to the adsorber system via pneumatic conveyance.

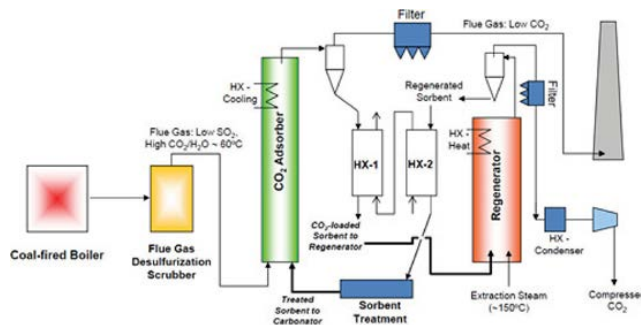

Figure 1: CACHYS™ Sorption Process

TABLE 1: ADSORPTION-BASED POST-COMBUSTION CO₂/N₂ SEPARATIONS

	Units	Current R&D Value	Target R&D Value
Sorbent			
True Density at STP	kg/m ³	1,800–2,200	1,800–2,200
Bulk Density	kg/m ³	400–700	400–700
Average Particle Diameter	mm	0.1–1	0.1–1
Particle Void Fraction	m ³ /m ³		
Packing Density	m ² /m ³	230	230
Solid Heat Capacity at STP	kJ/kg-K	1.2	1.2
Crush Strength	kg _f		
Manufacturing Cost for Sorbent	\$/kg	1.65	1.00
Absorption			
Pressure (partial of CO ₂)	bar	0.1	0.1
Temperature	°C	50–80	50–80
Equilibrium CO ₂ Loading	g mol CO ₂ /kg	2.1	2.1
Heat of Absorption	kJ/mol CO ₂	30–80	30–80
Desorption			
Pressure (partial of CO ₂)	bar	1.9	1.9
Temperature	°C	140–160	140–160
Equilibrium CO ₂ Loading	mol/mol	0.5	0.5
Heat of Desorption	kJ/mol CO ₂	30–80	30–80
Proposed Module Design		<i>(for equipment developers)</i>	
Flow Arrangement/Operation	—	fluidized bed	
Flue Gas Flowrate	kg/hr		
CO ₂ Recovery, Purity, and Pressure	%/%/bar	90%, 95–99%	
Adsorber Pressure Drop	bar		

Definitions:

STP – Standard Temperature and Pressure (15 °C, 1 atm).

Sorbent – Adsorbate-free (i.e., CO₂-free) and dry material as used in adsorption/desorption cycle.

Manufacturing Cost for Sorbent – “Current” is market price of material, if applicable; “Target” is estimated manufacturing cost for new materials, or the estimated cost of bulk manufacturing for existing materials.

Adsorption – The conditions of interest for adsorption are those that prevail at maximum sorbent loading, which typically occurs at the bottom of the adsorption column. These may be assumed to be 1 atm total flue-gas pressure (corresponding to a CO₂ partial pressure of 0.13 bar) and 40°C; however, measured data at other conditions are preferable to estimated data.

Desorption – The conditions of interest for desorption are those that prevail at minimum sorbent loading, which typically occurs at the bottom of the desorption column. Operating pressure and temperature for the desorber/stripper are process-dependent. Measured data at other conditions are preferable to estimated data.

Pressure – The pressure of CO₂ in equilibrium with the sorbent. If the vapor phase is pure CO₂, this is the total pressure; if it is a mixture of gases, this is the partial pressure of CO₂. Note that for a typical pulverized coal (PC) power plant, the total pressure of the flue gas is about 1 atm and the concentration of CO₂ is about 13.2 percent. Therefore, the partial pressure of CO₂ is roughly 0.132 atm or 0.130 bar.

Packing Density – Ratio of the active sorbent area to the bulk sorbent volume.

Loading – The basis for CO₂ loadings is mass of dry, adsorbate-free sorbent.

Flow Arrangement/Operation – Gas-solid module designs include fixed, fluidized, and moving bed, which result in either continuous, cyclic, or semi-regenerative operation.

technology advantages

- Low heat of sorption.
- Increased sorption kinetics.
- Low-cost sorbent.
- Commercially-available and easily-scalable equipment.

R&D challenges

- Confirmation of energetics.
- Sorbent integrity.
- Sorbent handling.
- Achievement of 90% CO₂ capture.

results to date/accomplishments

- Performed laboratory-scale testing that showed heat of desorption was 30–80 kJ/mol CO₂, depending on process conditions. Sorbent CO₂ working capacity ranged from 70–100 g/kg sorbent. Both metrics exceeded the target levels.
- 100-cycle tests demonstrated excellent chemical stability and no detectable loss in capacity.
- The CACHYS™ bench-scale test facility was constructed at UND’s coal-fired steam plant. The system captures CO₂ from 30 acfm of flue gas with a sorbent throughput of 200-400 lb/hr.
- Bench-scale parametric testing resulted in a maximum CO₂ capture of 85 percent and demonstrated the significant benefits of hybrid sorption compared to standard carbonate sorption: Much higher capture and reaction rates (≈2–3X) and excellent control of exothermic heat of adsorption.
- Continuous and integrated bench-scale testing demonstrated sustainable (5–7 hours) capture of 70–80 percent with 4 percent CO₂ in flue gas and 40–60 percent with 8 percent CO₂ in flue gas. A 15-hour continuous test with stable operations was completed.
- Based on the testing data gathered over the course of the project, a final technical and economic feasibility study was completed. Results indicate a modest improvement over the benchmark MEA process and progress towards the DOE goals.

next steps

This project ended December 31, 2014.

available reports/technical papers/presentations

Benson, S., et al., “Evaluation of CO₂ Capture from Existing Coal-fired Plants by Hybrid Sorption Using Solid Sorbents,” presented at the 2014 NETL CO₂ Capture Technology Meeting, Pittsburgh, PA, July 2014.

<http://www.netl.doe.gov/File%20Library/Events/2014/2014%20NETL%20CO2%20Capture/S-Benson-UNDakota-S-Srinivasachar-Envergex-Evaluation-of-CO2.pdf>.

Presentation at the Thirteenth Annual Conference on Carbon Capture, Utilization, and Storage, Pittsburgh, PA, April 28–May 1, 2014. <http://www.netl.doe.gov/File%20Library/Research/Coal/carbon%20capture/post-combustion/2014-CCUS-Presentation-7603.pdf>.

Benson, S., et al., “Evaluation of CO₂ Capture from Existing Coal-fired Plants by Hybrid Sorption Using Solid Sorbents,” presented at the 2013 NETL CO₂ Capture Technology Meeting, Pittsburgh, Pennsylvania, July 2013,

<http://www.netl.doe.gov/File%20Library/Events/2013/CO2%20Capture/S-Benson-UND-Hybrid-Sorption-Using-Solid-Sorbents.pdf>.

Benson, S., et al., “Evaluation of CO₂ Capture from Existing Coal-fired Plants by Hybrid Sorption Using Solid Sorbents,” presented at the 2012 NETL CO₂ Capture Technology Meeting, Pittsburgh, PA, July 2012.

Preliminary Carbon Dioxide Capture Technical and Economic Feasibility Study—Topical Report (November 2012).

Project Review Meeting Presentation (September 2012). <http://www.netl.doe.gov/File%20Library/Research/Coal/ewr/CO2/und-CO2-capture-budget-period1.pdf>.

Evaluation of CO₂ Capture from Existing Coal-Fired Power Plants by Hybrid Sorption Using Solid Sorbents (CACHYS™) Project Kick-Off Meeting Presentation, November 21, 2011. <http://www.netl.doe.gov/File%20Library/Research/Coal/ewr/CO2/und-CO2-capture-budget-period1.pdf>.

METAL MONOLITHIC AMINE-GRAFTED SILICA FOR CO₂ CAPTURE

primary project goals

The University of Akron set out to develop a low-cost carbon dioxide (CO₂) capture technology by integrating metal monoliths with a grafted amine sorbent.

technical goals

- 1.5 mmol-CO₂/g-sorbent.
- 1.0 mmol-sulfur dioxide (SO₂)/g-sorbent.
- 500 repeated thermal cycles of sorbent between CO₂ adsorption at 25°C and desorption at 110°C with less than a 10 percent degradation in original CO₂ capture capacity.

technical content

The key innovation of this project is the utilization of metal foils with amine-grafted porous silica to fabricate a highly efficient and low-cost CO₂ adsorption system. Porous silica, alumina, zeolite, and carbon, which are used as commercial adsorbents for a wide range of applications, are impregnated with alkyl amine molecules such as monoethanolamine (MEA)/tetraethylenepentamine. The adsorption capacity of this novel amine-grafted silica was determined to be greater than 1.5 mmol-CO₂/g-sorbent because of the abundance of available amine functional groups on the amine-grafted silica. The adsorption and desorption can be further optimized by the sorbent preparation procedures with additives.

The metal monolithic structure allows the rapid removal of heat of CO₂ adsorption. The surface of the metal monolith is coated with a layer of silica, carbon fibers, and a binder. Calcination of the metal monolith with this coating produces the silica or zeolite layers structure with 10- μ m diameter channels. The binder and carbon fiber concentration is fine-tuned to optimize the number of the micro channel pathways for CO₂ diffusion into the amine-grafted silica and zeolite.

The University of Akron, as part of this project, has also investigated using coal fly ash treated first with sodium hydroxide (NaOH) and/or hydrochloric acid (HCl), and then impregnated with the amine tetraethylenepentamine. Coal fly ash was investigated as a support for amine due to its ready availability and low cost.

technology maturity:

Pilot-Scale Using Simulated Flue Gas, 15 kW

project focus:

Metal Monolithic Amine-Grafted Zeolites

participant:

University of Akron

project number:

FC26-07NT43086

NETL project manager:

I. Andrew Aurelio
isaac.aurelio@netl.doe.gov

principal investigator:

Steven Chuang
University of Akron
chuang@uakron.edu

partners:

FirstEnergy

performance period:

2/21/2007 – 3/31/11

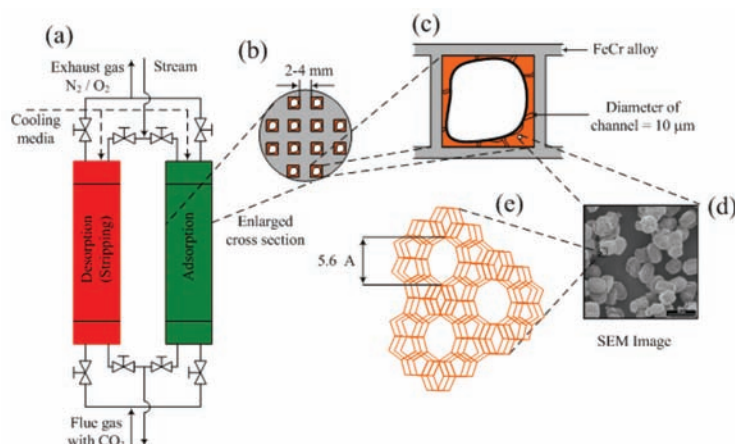

Figure 1: Metal Monolithic Amine-Grafted Silica Sorbents

Figure 1 displays the amine-grafted zeolite structure (5.6 Angstroms in length) inside an adsorption unit. The amine is located in the adsorption (a) chamber within holding tubes. The tubes housed in the adsorption unit holds the individual metal (b) tubes with the amine approximately 2 to 4 mm apart. The silica or zeolite is coated inside the square metal tube. Gas enters the tube and flows through the channels (d) of the amine grafted silica, which are 10 µm in diameter. Heating for CO₂ desorption (i.e., regeneration) and cooling for adsorption are achieved by 40 pounds per square inch gauge (psig) steam and cooling water flowing through the jacket side of the adsorber. Desorbed CO₂ is purged from the channels of metal monoliths by pulses of steam and hot air. The goal is that CO₂ and SO₂ adsorption capacity of the amine will be greater than 1.5 mmol-CO₂/g-sorbent and 1.0 mmol-CO₂/g-sorbent, respectively. The amine is capable of greater than 500 times regeneration with less than 10 percent degradation in CO₂ capacity. The amine-grafted silica sorbent is expected to exhibit a heat capacity of 1.5 kJ/kg K. The CO₂ will be captured at an approximate temperature of 50°C (140°F) and then released at approximately 110°C (230°F).

TABLE 1: PROCESS PARAMETERS FOR METAL MONOLITHIC AMINE-GRAFTED SILICA SORBENTS

	Units	Current R&D Value	Target R&D Value
Sorbent			
True Density @ STP	kg/m ³		
Bulk Density	kg/m ³	0.5	0.5
Average Particle Diameter	mm	0.05-1	<1
Particle Void Fraction	m ³ /m ³		
Packing Density	m ² /m ³	.43	<0.5
Solid Heat Capacity @ STP	kJ/kg-K		
Crush Strength	kg _f		
Manufacturing Cost for Sorbent	\$/kg	14	12
Adsorption			
Pressure	bar	1	1
Temperature	°C	50	<55
Equilibrium Loading	g mol CO ₂ /kg	2.4	3.1
Heat of Adsorption	kJ/mol CO ₂	60	55
Desorption			
Pressure	bar	1-1.05	1-1.05
Temperature	°C	100-110	100-110
Equilibrium Loading	g mol CO ₂ /kg	2.4	3.1
Heat of Desorption	kJ/mol CO ₂		

TABLE 1: PROCESS PARAMETERS FOR METAL MONOLITHIC AMINE-GRAFTED SILICA SORBENTS

	Units	Current R&D Value	Target R&D Value
Proposed Module Design		<i>(for equipment developers)</i>	
Flow Arrangement/Operation	-		
Flue Gas Flowrate	kg/hr		
CO ₂ Recovery, Purity, and Pressure	% / % / bar		
Adsorber Pressure Drop	bar		
Estimated Absorber/Stripper Cost of Manufacturing and Installation	$\frac{\$}{\text{kg/hr}}$		

Definitions:

STP – Standard Temperature and Pressure (15°C, 1 atm).

Sorbent – Adsorbate-free (i.e., CO₂-free) and dry material as used in adsorption/desorption cycle.

Manufacturing Cost for Sorbent – “Current” is market price of material, if applicable; “Target” is estimated manufacturing cost for new materials, or the estimated cost of bulk manufacturing for existing materials.

Adsorption – The conditions of interest for adsorption are those that prevail at maximum sorbent loading, which typically occurs at the bottom of the adsorption column. These may be assumed to be 1 atm total flue-gas pressure (corresponding to a CO₂ partial pressure of 0.13 bar) and 40°C; however, measured data at other conditions are preferable to estimated data.

Desorption – The conditions of interest for desorption are those that prevail at minimum sorbent loading, which typically occurs at the bottom of the desorption column. Operating pressure and temperature for the desorber/stripper are process-dependent. Measured data at other conditions are preferable to estimated data.

Pressure – The pressure of CO₂ in equilibrium with the sorbent. If the vapor phase is pure CO₂, this is the total pressure; if it is a mixture of gases, this is the partial pressure of CO₂. Note that for a typical pulverized coal (PC) power plant, the total pressure of the flue gas is about 1 atm and the concentration of CO₂ is about 13.2 percent. Therefore, the partial pressure of CO₂ is roughly 0.132 atm or 0.130 bar.

Packing Density – Ratio of the active sorbent area to the bulk sorbent volume.

Loading – The basis for CO₂ loadings is mass of dry, adsorbate-free sorbent.

Flow Arrangement/Operation – Gas-solid module designs include fixed, fluidized, and moving bed, which result in either continuous, cyclic, or semi-regenerative operation.

Estimated Cost – Basis is kg/hr of CO₂ in CO₂-rich product gas; assuming targets are met.

Other Parameter Descriptions:

Chemical/Physical Sorbent Mechanism – CO₂ + R-NH₂ → Carbamate/ammonium ions and Carbamic acid

Sorbent Contaminant Resistance – Sorbent capacity decreased by more than 50 percent after 30 cycles in 15 percent CO₂ and 250 parts per million (ppm) SO₂.

Sorbent Attrition and Thermal/Hydrothermal Stability – Sorbent capacity decreased by less than 10 percent after more than 500 cycles under thermal/hydrothermal conditions.

Flue Gas Pretreatment Requirements – Less than 20 ppm SO₂.

Sorbent Makeup Requirements – Less than 10 percent after 500 cycles.

Waste Streams Generated – Degraded sorbents will be re-activated.

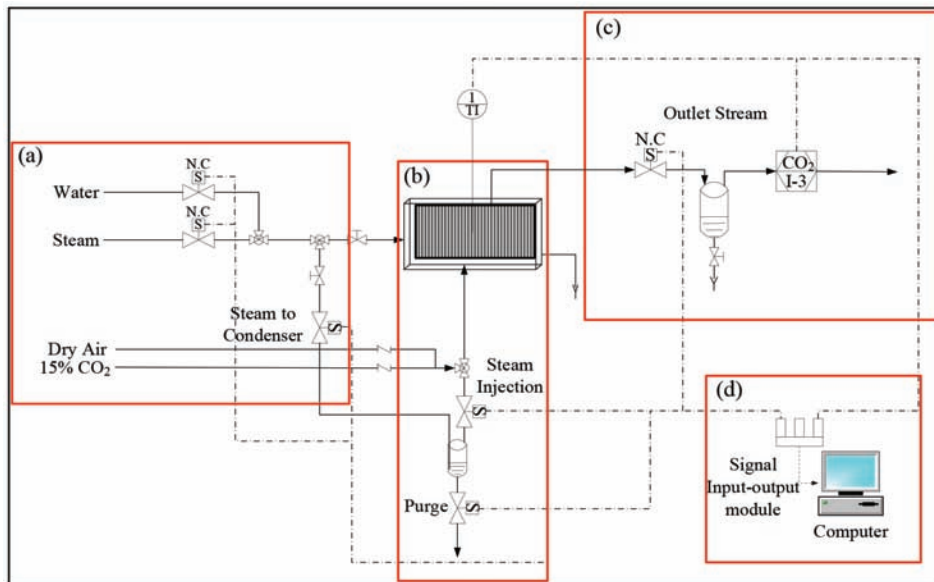

Figure 2: Process Schematic of the Monolith Adsorber

Adsorption temperature: $< 40^{\circ}\text{C}$; desorption temperature: 105 to 115°C ; pressure: 1 to 1.3 atm.

technology advantages

- High stability for CO_2 adsorption and desorption.
- Accelerated removal of the heat of adsorption.
- Low regeneration heat duty due to the low heat capacity of the sorbent.
- Low-cost immobilized amine sorbent.

R&D challenges

- The scale-up transition from lab- to bench-scale tests.
- Temperature swing adsorption requires a long cycle time due to the heating and cooling of the sorbent.
- Contaminants, such as sulfur oxides (SO_x), will react with amine functional groups similar to the MEA process.
- Currently, the CO_2 capture capacity of the sorbent is too low.

results to date/accomplishments

- The first generation of immobilized amine sorbents underwent 500 CO_2 capture cycles with less than 15 percent degradation. Refining in composition and preparation method resulted in sorbents with high stability for more than 1,100 CO_2 capture cycles, but lower capture capacity.
- Zeolite was shown to not be an effective support because of its hydrophilicity and small pore sizes.
- Developed a pilot-scale sorbent manufacturing process at a rate of 1 kg/hr.
- Enhanced the sorbent resistance to SO_2 poisoning by adding a proprietary additive to the CO_2 sorbent.

- A binder agent allows to agglomerate powder sorbents into rod or spherical pellets while maintaining the CO₂ capture capacity of the sorbent and yielding to low attrition rates.
- The operation under fixed-bed conditions present limitations in heat transfer: (1) slowing down the CO₂ capture process and (2) causing the sorbent to degrade.
- The CO₂ capture capacity could be increased 1.6 to 1.9 times when H₂O is present in the flue gas as compared to capture in dry conditions.
- Demonstrated the sorbent at pilot-scale, a 5-kg fixed bed. Adsorption was carried out at 55°C and desorption was with steam at 110°C.

next steps

This project ended on March 31, 2011.

available reports/technical papers/presentations

Chuang, S.S.C., "Amine absorber for carbon dioxide capture and processes for making and using the same,"

US 8377173 B₂, US Patent, Publication date: Feb. 19, 2013.

Chuang, S.S.C., "Metal Monolithic Amine-Grafted Zeolites for CO₂ Capture Power Plants," presented at the 2010 NETL CO₂ Capture Technology Meeting, Pittsburgh, Pennsylvania, September 2010. <http://www.netl.doe.gov/publications/proceedings/10/co2capture/presentations/monday/Steven%20Chuang-NT43086.pdf>.

Chuang, S.S.C.; Fisher, J.; and Tanthana, J., "Metal Monolithic Amine-grafted Zeolites for CO₂ Capture," presented at the Annual NETL CO₂ Capture Technology for Existing Plants R&D Meeting, Pittsburgh, Pennsylvania, March 2009. <http://www.netl.doe.gov/publications/proceedings/09/CO2/pdfs/43086%20Akron%20amine-zeolite%20sorbent%20%28Chuang%29%20mar09.pdf>.

Tanthana, J., and Chuang, S.S. C., "In Situ Infrared Study of the Role of PEG in Stabilizing Silica-Supported Amines for CO₂ Capture," *Chemical & Sustainability Energy & Materials*, 3, 957-964, 2010. <http://onlinelibrary.wiley.com/doi/10.1002/cssc.201000090/abstract>.

Fisher II, J.C.; Tanthana, J.; and Chuang, S.S.C., "Oxide-supported Tetraethylenepentamine for Carbon Dioxide Capture," *Environmental Progress & Sust Energy*, 28 (4), 589-598, 2009. <http://onlinelibrary.wiley.com/doi/10.1002/ep.10363/abstract>.

CO₂ REMOVAL FROM FLUE GAS USING MICROPOROUS METAL ORGANIC FRAMEWORKS

primary project goals

UOP set out to design and develop a carbon dioxide (CO₂) removal system that employs metal organic framework (MOF) sorbents.

technical goals

- Use combinatorial chemistry to systematically synthesize and characterize a wide range of MOF and related materials.
- Screen materials for hydrothermal stability.
- Collect isotherm data for subsequent development and optimization.
- Determine the effects of water on CO₂ adsorption.
- Develop and validate material scale-up and forming procedures.
- Select the best one or two materials for final optimization and scale-up.
- Determine the effects of contaminants on the performance of scaled-up materials.
- Understand detailed kinetic and equilibrium data for incorporation in a process design and an economic analysis.

technical content

MOFs are extremely high surface area, crystalline, microporous, and thermally stable materials that have shown exceptional storage capacity for CO₂, methane, hydrogen, and other gases. MOFs typically consist of transition metal vertices, or hubs, attached three-dimensionally to other metal vertices by organic “linker” molecules. After removal of reaction solvent, the resulting porosity can be adjusted by simply changing the length or composition of the molecules used to link the metal vertices. Well-ordered openings, channels, and pockets in the structures are from a few angstroms to tens of angstroms. Figure 1 represents the building blocks used to create prototypical MOF-5, in which the green ball represents the metal-containing hub, and the yellow cylinder represents the organic linker.

technology maturity:

Laboratory-Scale, Simulated Flue Gas

project focus:

CO₂ Removal from Flue Gas Using Microporous MOFs

participant:

UOP

project number:

FC26-07NT43092

NETL project manager:

David Lang

david.lang@netl.doe.gov

principal investigator:

Richard Willis

UOP LLC

richard.willis@uop.com

partners:

University of Edinburgh

University of Michigan

Vanderbilt University

Northwestern University

performance period:

3/12/07 – 6/30/10

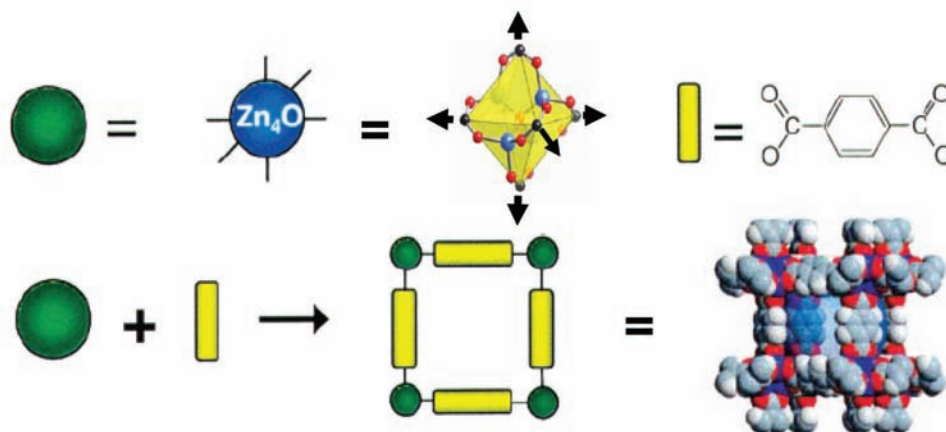

Figure 1: Building Blocks Used to Create Prototypical MOF-5

More than 50 MOFs for CO₂ adsorption were prepared from literature reports or designed by the experimenters. Table 1 displays the top MOFs for CO₂ capture.

TABLE 1: TOP 10 MOFS FOR CO₂ CAPTURE

Sample	Loading (mol/kg)	Loading (wt%)	Heat of Absorption (kJ/mol)
Mg\DOBDC (2)	4.73	20.9	60.1
Ni\DOBDC	3.40	15.0	27.2
Co\DOBDC	1.84	8.1	19.9
Mg\DOBDC (1)	1.28	5.6	21.3
HKUST-1 (CuBTC)	0.42	1.8	23.3
Zn\DOBDC	0.41	1.8	22.9
A1-MIL-110	0.24	1.1	21.7
Cr-MIL-101	0.18	0.8	13.3
Tb-MOF-76	0.18	0.8	21.7
A1-MIL-53	0.17	0.7	26
Zn-IRMOF-1	0.13	0.6	13.5

MOF-based adsorbents will be utilized in a vacuum pressure swing adsorption (VPSA) process for removal of CO₂ from flue gas. Figure 2 represents an example of MOF CO₂ adsorption capabilities as a function of pressure (for M/DOBDC, M represents the metal).

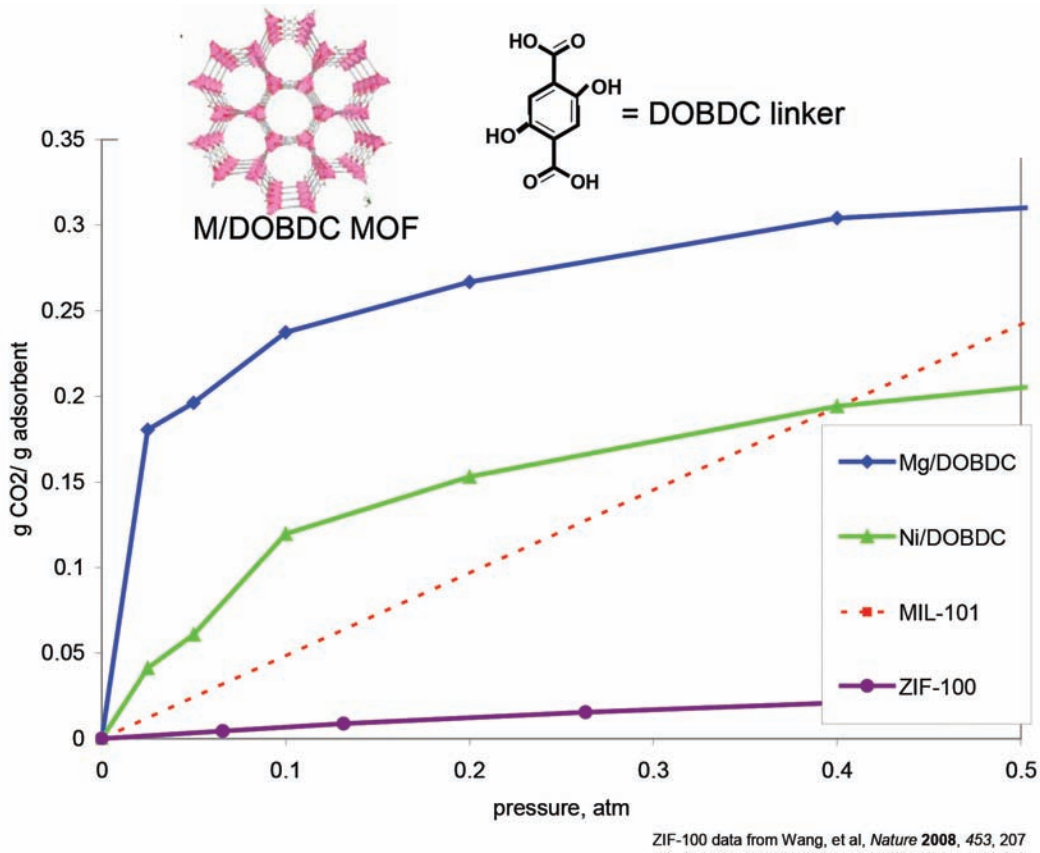

Figure 2: Example of MOF CO₂ Adsorption Capabilities as a Function of Pressure

The MOF-based VPSA CO₂ recovery system will be located after a contaminant-removal section and before the final CO₂ compression and drying section. The nitrogen (N₂)-rich waste stream (raffinate) will be sent to the stack. A process schematic is provided in Figure 3.

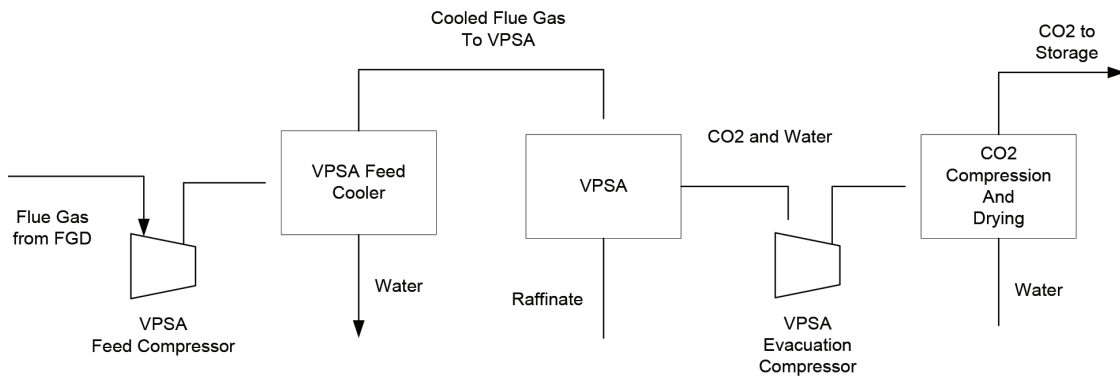

Figure 3: The MOF-Based CO₂ Capture System Process Schematic

Downstream from the flue gas desulfurization (FGD) and polishing scrubber, flue gas pressure is boosted in the VPSA feed compressor by approximately 4.8 pounds per square inch (psi) to make up for pressure drop in the contaminant-removal section and to maximize the adsorption of CO₂ in the VPSA unit. The VPSA feed compressor will be followed by a VPSA feed cooler to lower the temperature of the flue gas to approximately 100°F. It is likely that two parallel operating VPSA feed compressor and VPSA feed cooler trains will be required. Compressing and cooling the flue gas to 100°F will reduce the flue gas volume flow rate (actual cubic feet per minute [ACFM]) by up to 35 percent, and concurrently knock out at least 75 percent of the water vapor originally present in the flue gas. The combined lower-volume, lower-temperature, and lower-water content will allow the VPSA unit to operate more efficiently and effectively on the resultant flue gas stream.

The cooled flue gas enters the VPSA unit and will flow in a radial fashion through a short bed of adsorbent in either a vertical or horizontal configuration, depending upon the particular power plant's requirements. The adsorbent beds will consist of alumina for moisture polishing, and MOF for CO₂ removal. In the VPSA conceptual design at the end of the adsorption step, the vessel first vents N₂ raffinate to the stack to reduce the bed pressure to atmospheric pressure; pressure then equalizes with another vessel that had just completed the vacuum regeneration step. This would reduce the bed pressure to 7 to 8 pounds per square inch absolute (psia). These steps also reduce the N₂ stored in the vessel voids and minimize the amount that would be co-produced with the CO₂. The adsorbent bed would then be evacuated to 0.5 psia to produce the CO₂. For the purposes of the calculations, it was assumed that there was negligible co-adsorption of N₂ on the CO₂-loaded adsorbent and that the N₂ was primarily stored in the voids of the adsorbent vessel. The target CO₂ delta loadings were based on producing a >90 percent CO₂ purity stream during the regeneration step. The parasitic load for regeneration of the adsorbent is the compression energy associated with evacuating the vessel to 0.5 psia and compressing the contents to at least 8.8 pounds per square inch gauge (psig). The contribution of the N₂ stored in the voids is quite small compared to the compression energy associated with desorbing the CO₂. A purge step was not used in this process since the primary concern is producing a high-purity CO₂ stream.

The VPSA evacuation compressor will be used to remove CO₂ streams at 95 to 97 percent purity from the adsorbent beds. The water that comes along with the CO₂ will be removed during the CO₂ compression and drying stage of the process. In order to facilitate the gas compression and drying section CAPEX estimate, the VPSA evacuation compressor discharge pressure is 8.8 psig. This is the same pressure that the Econamine process delivers captured CO₂ to the gas compression and drying section. In the compression section, the CO₂ is compressed to 2,215 psia by a six-stage centrifugal compressor with inter-stage cooling to 100°F. The discharge pressures of the stages were balanced to give reasonable power distribution and discharge temperatures across the various stages. During compression in the multiple-stage, intercooled compressor, the CO₂ stream is dehydrated to a dew point of -40°F with triethylene glycol. The virtually moisture-free supercritical CO₂ stream is delivered to the plant battery limit as sequestration-ready.

There are no heating or cooling steps within the VPSA unit operation, which is typical of VPSA processes. Since this is still a conceptual design, however, there remain other types of processes to consider depending upon future pilot study and other experimental results. In a VPSA process, the heat of adsorption is released and is stored in the bed by a sensible temperature rise. The heat is removed during the desorption step as the adsorbent bed cools. Approximately 90 percent of the CO₂ in the feed gas is adsorbed onto the MOF adsorbent, and the rest leaves the VPSA section to the stack. Further, other than spent adsorbent, there is no waste generated in this process. The MOF-based VPSA process should generate little waste because the adsorbent itself is not hazardous waste, nor is it expected that the MOF will generate any hazardous waste products via degradation.

TABLE 2: ADSORPTION-BASED POST-COMBUSTION CO₂/N₂ SEPARATIONS

	Units	Current R&D Value	Target R&D Value
Sorbent			
True Density @ STP	kg/m ³	0.8	1.0
Bulk Density	kg/m ³		
Average Particle Diameter	mm	0.5 – 2.0	1.0
Particle Void Fraction	m ³ /m ³		
Packing Density	m ² /m ³	0.5	0.7
Solid Heat Capacity @ STP	kJ/kg-K	≈ 1	< 1
Crush Strength	kg _r		
Manufacturing Cost for Sorbent	\$/kg		

TABLE 2: ADSORPTION-BASED POST-COMBUSTION CO₂/N₂ SEPARATIONS

	Units	Current R&D Value	Target R&D Value
Adsorption			
Pressure	bar	0.1	0.1 – 0.15
Temperature	°C	25 – 45	25 – 45
Equilibrium Loading	g mol CO ₂ /kg-sorbent		
Heat of Adsorption	kJ/mol CO ₂	45	45 – 55
Desorption			
Pressure	bar	0.01 – 0.05	0.05
Temperature	°C	Ambient	Ambient
Equilibrium Loading	g mol CO ₂ /kg-sorbent		
Heat of Desorption	kJ/mol CO ₂		
Proposed Module Design		<i>(for equipment developers)</i>	
Flow Arrangement/Operation	-	---	---
Flue Gas Flowrate	kg/hr	---	---
CO ₂ Recovery, Purity, and Pressure	% / % / bar	90–98	
Adsorber Pressure Drop	bar	---	---
Estimated Absorber/Stripper Cost of Manufacturing and Installation	$\frac{\$}{\text{kg/hr}}$	---	---

Definitions:

STP – Standard Temperature and Pressure (15°C, 1 atm).

Sorbent – Adsorbate-free (i.e., CO₂-free) and dry material as used in adsorption/desorption cycle.

Manufacturing Cost for Sorbent – “Current” is market price of material, if applicable; “Target” is estimated manufacturing cost for new materials, or the estimated cost of bulk manufacturing for existing materials.

Adsorption – The conditions of interest for adsorption are those that prevail at maximum sorbent loading, which typically occurs at the bottom of the adsorption column. These may be assumed to be 1 atm total flue-gas pressure (corresponding to a CO₂ partial pressure of 0.13 bar) and 40°C; however, measured data at other conditions are preferable to estimated data.

Desorption – The conditions of interest for desorption are those that prevail at minimum sorbent loading, which typically occurs at the bottom of the desorption column. Operating pressure and temperature for the desorber/stripper are process-dependent. Measured data at other conditions are preferable to estimated data.

Pressure – The pressure of CO₂ in equilibrium with the sorbent. If the vapor phase is pure CO₂, this is the total pressure; if it is a mixture of gases, this is the partial pressure of CO₂. Note that for a typical pulverized coal (PC) power plant, the total pressure of the flue gas is about 1 atm and the concentration of CO₂ is about 13.2 percent. Therefore, the partial pressure of CO₂ is roughly 0.132 atm or 0.130 bar.

Packing Density – Ratio of the active sorbent area to the bulk sorbent volume.

Loading – The basis for CO₂ loadings is mass of dry, adsorbate-free sorbent.

Flow Arrangement/Operation – Gas-solid module designs include fixed, fluidized, and moving bed, which result in either continuous, cyclic, or semi-regenerative operation.

Estimated Cost – Basis is kg/hr of CO₂ in CO₂-rich product gas; assuming targets are met.

technology advantages

- High CO₂ adsorption capacity.
- Good adsorption/desorption rates.
- Good hydrothermal stability.
- Environmentally friendly.

R&D challenges

- Effects of water, sulfur oxides (SO_x), and nitrogen oxides (NO_x) on the MOF material.
- Need for large vacuum pumps to compress the CO₂ from the outlet of the VPSA.

results to date/accomplishments

- More than 50 MOF materials were evaluated; two were selected for further development and testing. The CO₂ capacity for these MOFs was determined in the presence of water and other contaminants and measured at several temperatures. Hydrothermal stability testing at accelerated conditions was also carried out for these MOFs.
- Mg/DOBDC outperformed all MOF and zeolite materials evaluated, with about 25 wt% CO₂ captured by this MOF at flue gas conditions (≈0.13 atm CO₂ pressure, 311°K).
- UOP's techno-economic analysis indicated that an MOF-based VPSA process has potential to be a less-expensive option than using amines to capture CO₂. Their analysis indicated a 65 percent increase in cost of electricity (COE) compared to a reference power plant without CO₂ capture.

next steps

This project ended on June 30, 2010. The final report was issued in October 2010.

available reports/technical papers/presentations

Carbon Dioxide Removal from Flue Gas Using Microporous Metal Organic Frameworks [PDF-2.7MB] (Oct 2010) Final Technical Report.

Benin, A., et al., "CO₂ Removal from Flue Gas Using Microporous Metal Organic Frameworks," presented at the Annual NETL CO₂ Capture Technology for Existing Plants R&D Meeting, Pittsburgh, Pennsylvania, March 2009. <http://www.netl.doe.gov/publications/proceedings/09/CO2/pdfs/43092%20UOP%20MOF%20sorbent%20%28Benin%29%20public%20version%20mar09.pdf>

DEVELOPMENT OF A DRY SORBENT-BASED POST-COMBUSTION CO₂ CAPTURE TECHNOLOGY FOR RETROFIT IN EXISTING POWER PLANTS

primary project goals

Research Triangle Institute (RTI) developed and tested a carbon dioxide (CO₂) capture process that utilizes a dry sodium carbonate (Na₂CO₃) sorbent that is based on the reaction of Na₂CO₃ with CO₂ and water vapor present in the flue gas from a coal-fired power plant.

technical goals

- Determine the optimal process configuration for the dry carbonate process.
- Construct and demonstrate a bench-scale CO₂ capture process using Na₂CO₃.
- Construct and demonstrate a pilot-scale, dry carbonate process that captures 0.9 tonnes of CO₂/day (1 ton of CO₂/day).
- Demonstrate the long-term chemical and mechanical stability of the sorbent.
- Update the economic analyses of the CO₂ sorbent capture process.
- Develop a commercialization plan for instituting the CO₂ capture process.

technical content

In an effort to develop a pre-pilot scale facility, RTI has been collecting data needed for designing, constructing, and operating the dry sorbent-based capture unit. RTI has designed and constructed a bench-scale heat transfer evaluation unit, shown in Figure 1, which is used to experimentally determine realistic gas and solid circulation rates and overall heat transfer coefficients for new reactor designs. A schematic diagram of the process is shown in Figure 1.

technology maturity:

Bench-Scale/Small Pilot-Scale

project focus:

A Dry Sorbent-Based Post Combustion CO₂ Capture

participant:

RTI International

project number:

FC26-07NT43089

NETL project manager:

José Figueroa

jose.figueroa@netl.doe.gov

principal investigator:

Thomas Nelson

RTI International

tnelson@rti.org

partners:

Arcadis

ADA-ES

BOC

EPA

EPRI

Nexant

Süd-Chemie, Inc

performance period:

3/7/07 – 12/31/09

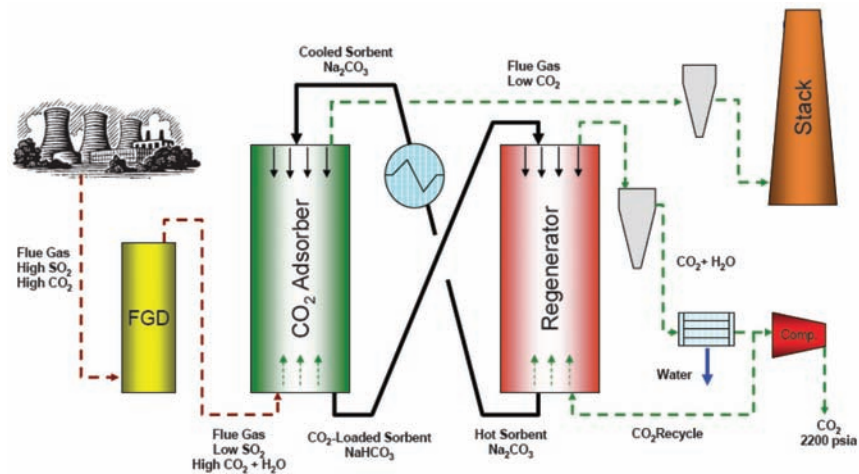

Figure 1: Schematic Diagram of CO₂ Capture Process



Figure 2: Lab-Scale CO₂ Absorption Reactor Skid

Pilot-scale testing will be performed on a slipstream from the air-blown gasifier at the National Carbon Capture Center (NCCC) in Wilsonville, Alabama. SRI has designed a pilot-scale, continuous, integrated test system. The equipment is being procured and will be assembled. The pilot-scale test will emphasize stability of integrated operation. The effects of trace contaminants will be observed, as the pilot tests will use a gas stream from an operating gasifier that has undergone minimum cleanup and will contain trace contaminants.

The CO₂ capture unit is located after the wet flue gas desulfurization (FGD) unit. The Na₂CO₃ sorbent reacts with the CO₂ and water (H₂O) located in the gas stream through a cyclic temperature swing cycle by adsorbing the CO₂ and H₂O at 60°C and releasing the constituents at 120°C during the sorbent regenerating stage. Considering the high exothermic heat of absorption (3.08 MJ/kg), significant cooling fluid is required to maintain the adsorption temperature at the desired value.

Utilizing the information gathered from the bench-scale unit, as well as the lab-scale unit shown in Figure 2, RTI has developed engineered sorbents that exhibit improved CO₂ capture rate and physical characteristics (e.g., attrition resistance, fluidizability, and density) over the supported (multi-layer) sorbents. These improvements will have a significant impact on a commercial, dry carbonate system by lowering the solids handling requirements and minimizing the heating and cooling duties in a commercial process. A long-term, multi-cycle testing of these sorbents to demonstrate chemical stability has been undertaken. Initial results indicate that the engineered sorbents are highly stable in the presence of contaminants such as hydrochloric acid (HCl), nitrous oxides (NO_x), H₂O, and oxygen (O₂). While sulfur dioxide (SO₂) forms irreversible chemical bonds to the sorbent, it is considered a minor issue, considering the rate of attrition is generally greater than the rate of deactivation due to SO₂.

TABLE 1: PHYSICAL PROPERTIES OF SODIUM CARBONATE SORBENTS

Property	Value
Bulk Density	1.0 – 1.1 g/mL
Average Particulate Size	65 – 75 μm
Surface Area	100 – 120 m ² /g
Physical Strength (A)	0.77
Na ₂ CO ₃ Strength	10 – 40 wt%
Heat of Absorption	3.08 MJ/kg
Regeneration Energy	3.08 MJ/kg

The heat transfer experiments will be conducted in a fluidized bed contactor, as shown in Figure 2. The conveyors (one heated, the other cooled) will be used to move the Na₂CO₃ through the fluidized bed to introduce a simulated flue gas (from coal or natural gas) to the sorbent. The instrument is used to analyze the adsorption effectiveness and the attrition rate of the Na₂CO₃ sorbent. Data from the fluidized bed will be used to validate and develop the computational fluid dynamic (CFD) model called MFIX.

Some physical properties of the sorbent are provided in Table 1.

As seen in the aforementioned table, the theoretical maximum CO₂ loading for the sorbent is ≈40 wt%. While RTI has achieved loading as high as 30 wt%, it requires a cycle time much greater than would be practical. Allowing only 30 minutes per cycle phase results in loading capacities of ≈20 to 25 percent.

technology advantages

- Lower capital and operating costs for CO₂ removal.
- Sorbent is inexpensive and easy to acquire (≈\$200/ton).
- Sorbent is non-hazardous, non-toxic, and does not produce hazardous waste.

R&D challenges

- Circulation of solids may be problematic.
- The reaction of Na₂CO₃ with H₂O is highly exothermic and requires effective heat transfer.
- Removal of CO₂ requires equimolar amounts of H₂O.
- Irreversible reactions of Na₂CO₃ with SO₂ and HCl during process conditions.
- Raw Na₂CO₃ is not a physically strong material, leading to high attrition rates.
- Raw Na₂CO₃ agglomerates upon contact with condensed H₂O.

results to date/accomplishments

- Constructed a heat transfer evaluation system used to evaluate the hydrodynamics and heat transfer characteristics of the reactor designs.
- Constructed a packed-bed reactor system to demonstrate sorbent stability over many adsorption and regeneration cycles and provide insight into reaction kinetics.
- Validated the operation of a bench-scale, coupled cold-flow system and collected data on gas-solid contactor bed height control, range of operability, sorbent bed densities, bed void volumes, and fluidization characteristics.
- Measured the heat transfer limitations of the existing screw conveyor system and determined that the screw conveyors cannot be used for sorbent regeneration in a 1-ton/day CO₂ capture pre-pilot system.
- Developed updated process simulations for the new dry carbonate process design using ASPEN Plus.

next steps

This project ended on December 31, 2009. The final report was completed in April 2010.

available reports/technical papers/presentations

Development of a Dry Sorbent-Based Post Combustion CO₂ Capture Technology for Retrofit in Existing Power Plants – Final Report – April 2010.

Nelson, T., et al., “Development of a Dry Sorbent-Based Post Combustion CO₂ Capture Technology Retrofit in Existing Power Plants,” presented at the Annual NETL CO₂ Capture Technology for Existing Plants R&D Meeting, Pittsburgh, Pennsylvania, March 2009. <http://www.netl.doe.gov/publications/proceedings/09/CO2/pdfs/43089%20RTI%20sorbent%20%28Nelson%29%20mar09.pdf>.

The Dry Carbonate Process: Carbon Dioxide Recovery from Power Plant Flue Gas, 7th Annual Conference on Carbon Capture and Sequestration in Pittsburgh, Pennsylvania, May 2008.

The Dry Carbonate Sorbent Technology for CO₂ Removal from Flue Gas of Existing Coal-Fired Power Plants – Power Plant Air Pollutant Control “Mega” Symposium in Baltimore, Maryland, August 2008.

Development of a Dry Sorbent-Based Post Combustion CO₂ Capture Technology for Retrofit in Existing Power Plants Fact Sheet, April 2008.

Carbon Dioxide Capture from Flue Gas Using Dry Regenerable Sorbents, Topical Report, November 2004.

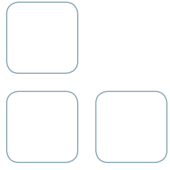

POST-COMBUSTION MEMBRANE TECHNOLOGIES



PILOT TEST OF A NANOPOROUS, SUPER-HYDROPHOBIC MEMBRANE CONTACTOR PROCESS FOR POST-COMBUSTION CARBON DIOXIDE CAPTURE

primary project goals

GTI is designing, constructing, and operating a pilot-scale system for post-combustion carbon dioxide (CO₂) capture using their novel hybrid membrane/absorption process made up of a hollow-fiber-membrane contactor facilitating CO₂ transfer across the membrane into a solvent to achieve a reduction in carbon capture cost.

technical goals

- Design and construct a 0.5-MWe pilot-scale test unit using GTI’s hollow fiber contactor (HFC).
- Install pilot-scale test unit at the National Carbon Capture Center (NCCC).
- Conduct pilot-scale tests with actual flue gas to gather data for further scaleup of the process.
- Complete final techno-economic and EH&S assessments.

technical content

GTI is building a 0.5 MWe pilot-scale CO₂ capture hollow fiber contactor system using polyether ether ketone (PEEK) hollow fibers in a membrane contactor. This effort represents the scaleup of technology developed on the bench scale under a previous project (DE-FE0004787). The pilot-scale contactor, to be tested in continuous, steady-state operation for a minimum of two months using coal-fired flue gas at the NCCC, provides operating data for further process scaleup. The proposed absorber skid for integration into the NCCC facility is shown in Figure 1.

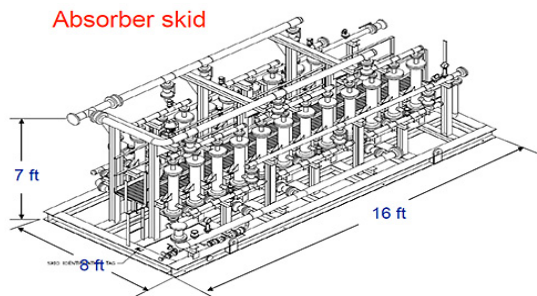

Figure 1: Conceptual Diagram for the Pilot-Scale Test Skid

technology maturity:

Pilot-Scale, Actual Flue Gas (0.5 MWe)

project focus:

Hollow-Fiber-Membrane Contactor with aMDEA Solvent

participant:

Gas Technology Institute

project number:

FE0012829, FE0004787

NETL project manager:

José Figueroa
jose.figueroa@netl.doe.gov

principal investigator:

Shaojun Zhou
Gas Technology Institute
shaojun.zhou@gastechnology.org

partners:

PoroGen Corporation
Trimeric Corporation
Midwest Generation EME, LLC

performance period:

10/1/10 – 6/30/18

This hybrid technology for CO₂ capture is based on a combination of solvent absorption and hollow-fiber-membrane technologies. The membrane contactor is a novel gas separation technology based on a gas/liquid membrane concept. In this process, CO₂-containing flue gas passes through one side of the PEEK HFC, while a CO₂ selective solvent (for example, activated MDEA) flows on the other side. Carbon dioxide permeates through the hollow-fiber-membrane pores and is chemically absorbed into the solvent. The CO₂-rich solvent is regenerated in a second PEEK HFC module operated in a reverse manner. The membrane contactor process combines the advantageous features of membrane and absorption technologies and enables economical utilization of advanced absorption solvents.

Figure 2 shows the basic mass transfer principle using the porous, hollow-fiber PEEK membrane contactor. The membrane matrix is filled with gas and mass transfer occurs via a diffusion reaction mechanism. The driving force is the difference in chemical potential of the CO₂ in the gas side versus the liquid side of the membrane; The mass transfer is not pressure-driven and, therefore, the absolute pressure difference between the membrane shell and tube side is either low or close to zero.

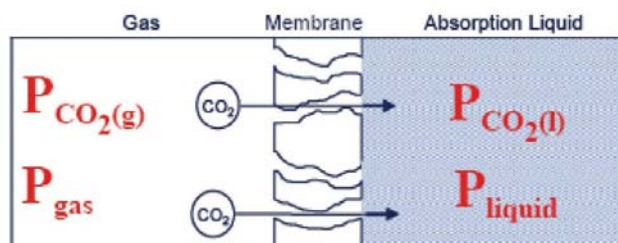

Figure 2: Mass Transfer Principle for Hybrid Membrane/Solvent Contactor

An advanced hindered amine and promoted carbonate solvents were tested in combination with the membrane contactor system. The use of these solvents will decrease regeneration energy requirements as well as absorbent degradation. For the hindered amine solvent, the regeneration will be carried out in a membrane contactor at high temperature to generate CO₂ at elevated pressure. For the carbonate solvent, the regeneration will be carried out in a membrane contactor with low-pressure steam sweep to decrease regeneration energy. Both solvent systems were evaluated and a hindered amine system, was selected for the bench-scale field tests. Figure 3 shows a schematic diagram for the hybrid membrane/solvent process showing the absorber (membrane contactor) and regeneration columns.

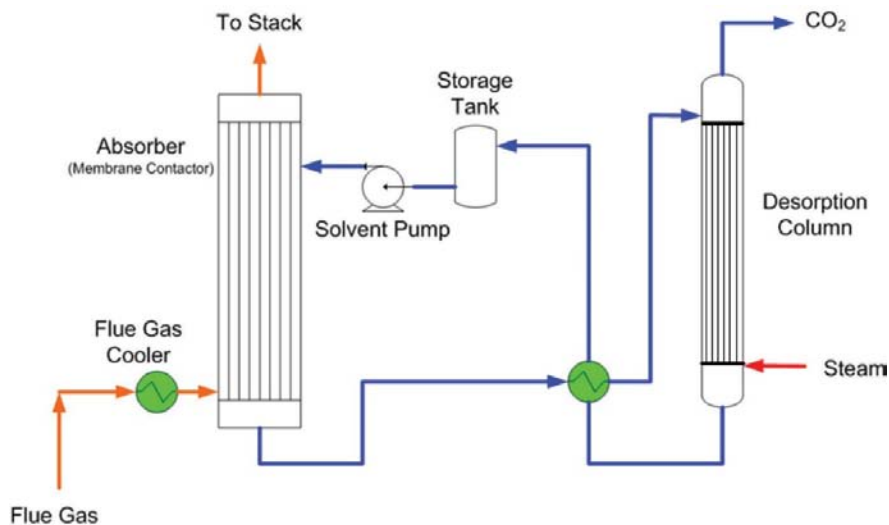

Figure 3: Process Schematic for Hybrid Membrane/Solvent Technology

The main process features of the hybrid membrane/solvent technology include: a higher CO₂ loading differential between rich and lean solvent is possible; increased mass transfer reduces system size; high specific surface area available for mass transfer;

independent gas and liquid flow; linear scaleup; and concentrated solvents or specialty absorbents can be used. Table 1 provides a summary of the membrane process parameters.

TABLE 1: GTI MEMBRANE PARAMETERS

	Units	Current R&D Value	Target R&D Value
Materials Properties			
Materials of Fabrication for Selective Layer	—	Not applicable for membrane contactor	
Materials of Fabrication for Support Layer	—	PEEK	
Nominal Thickness of Selective Layer	μm	Not applicable for membrane contactor	
Membrane Geometry	—	Hollow fiber	Hollow fiber
Max Trans-Membrane Pressure	bar	4	4
Hours Tested Without Significant Degradation	—	300 hours	≥60 days
Manufacturing Cost for Membrane Material	\$/m ²	80	30
Membrane Performance			
Temperature	°C	Absorber: ≈40 °C Desorber: 100–140 °C	Absorber: ≈40 °C Desorber: 100–140 °C
CO ₂ Pressure Normalized Flux	GPU or equivalent	2,000	2,000
CO ₂ /H ₂ O Selectivity	—	Not applicable	Not applicable
CO ₂ /N ₂ Selectivity	—	>1,000	>1,000
CO ₂ /SO ₂ Selectivity	—	0.64	0.64
Type of Measurement	—	Mixed gas	Mixed gas
Proposed Module Design		<i>(for equipment developers)</i>	
Flow Arrangement	—	Counter-current hollow fiber	
Packing Density	m ² /m ³	2,000	
Shell-Side Fluid	—	Liquid solvent	
Flue Gas Flowrate	kg/hr	4,300	
CO ₂ Recovery, Purity, and Pressure	%/%/bar	90/97/1.2	
Pressure Drops Shell/Tube Side	bar	0.14–0.55	

Definitions:

Membrane Geometry – Flat discs or sheets, hollow fibers, tubes, etc.

Pressure Normalized Flux – For materials that display a linear dependence of flux on partial pressure differential, this is equivalent to the membrane's permeance.

GPU – Gas Permeation Unit, which is equivalent to 10⁻⁶ cm³ (1 atm, 0 °C)/cm²/s/cm Hg. For non-linear materials, the dimensional units reported should be based on flux measured in cm³ (1 atm, 0 °C)/cm²/s with pressures measured in cm Hg.

Note: 1 GPU = 3.3464 × 10⁻⁶ kg mol/m²-s-kPa [SI units].

Type of Measurement – Either mixed or pure gas measurements; target permeance and selectivities should be for mixture of gases found in de-sulfurized flue gas.

Flow Arrangement – Typical gas-separation module designs include spiral-wound sheets, hollow-fiber bundles, shell-and-tube, and plate-and-frame, which result in either cocurrent, countercurrent, crossflow arrangements, or some complex combination of these.

Packing Density – Ratio of the active surface area of the membrane to the volume of the module.

Shell-Side Fluid – Either the permeate (CO₂-rich) or retentate (flue gas) stream.

Estimated Cost – Basis is kg/hr of CO₂ in CO₂-rich product gas; assuming targets are met.

**Proposed Module Design Assumptions* – Assume the module is located after the flue gas desulfurization (FGD), and that flue gas pressure is 15.4 psia, temperature is 155 °F, and composition (wet basis) are:

Composition (% vol)					Composition (ppmv)	
CO ₂	H ₂ O	N ₂	O ₂	Ar	SO _x	NO _x
14.0	13.0	68.5	4.5	0	2.5	-

These are average flue gas conditions at NCCC.

Other Parameter Descriptions:

Membrane Permeation Mechanism – The hybrid membrane/absorption process is driven by the chemical potential difference of CO₂ between the gas phase and the solvent phase and high purity of CO₂ product can be generated in a single stage. The process selectivity for the hybrid membrane/absorption process approaches thousands and is determined by the chemical affinity of the absorption solvent to CO₂. As compared with the conventional membrane process, the permeate side partial pressure of CO₂ can be considered to be close to zero due to the chemical interaction of CO₂ with the absorption solvent. Therefore, the pressure ratio in the hybrid membrane/absorption process approaches infinity. Note that membrane selectivity is not required in a hybrid membrane/absorption process, although the porous super-hydrophobic membranes used in this project showed some selectivity for CO₂ over N₂.

Contaminant Resistance – Membrane is resistant to flue gas contaminants. Absorbents will be affected by contaminants to a lesser extent than a conventional packed or tray column. Membrane will provide a measure of protection for the solvents from degradation by contaminants (a barrier).

Flue Gas Pretreatment Requirements – Particle removal.

Membrane Replacement Requirements – To be determined with actual coal-fired flue gas, however 5 year life is estimated based on field data of PEEK commercial membrane used in natural gas industry.

Waste Streams Generated – None.

Process Design Concept – See Figure 3.

technology advantages

- The membrane contactor process combines the advantageous features of membrane and absorption technologies and enables economical utilization of advanced absorption solvents.
- The hybrid technology increases interfacial gas/liquid area by a factor of 10 over conventional packed or tray absorption columns, thus increasing mass transfer.
- The process requires lower steam regeneration energy compared to conventional amine-based solvent processes.
- The CO₂ is generated at pressure, reducing compression costs.
- Up to 70 percent reduction in system size and footprint compared to a conventional solvent-based process.
- The technology under development has a cost that can be 25 percent lower than DOE's benchmark amine technology.

R&D challenges

- Membrane pressure drop issues.
- Mass transfer coefficient not sufficiently high for gas absorption and solvent regeneration in the membrane contactor.
- Develop solvent regeneration process in membrane module.

results to date/accomplishments

- The feasibility of utilizing PEEK- based hollow fiber contactor (HFC) in combination with chemical solvents to separate and capture at least 90 percent of the CO₂ from simulated flue gases was established: >2,000 membrane intrinsic CO₂ permeance, >90 percent CO₂ removal in one stage, <2 psi gas side pressure drop, and >1 (sec)⁻¹ mass transfer coefficient. Initial test results show that the CO₂ capture performance, using activated methyl diethanolamine (aMDEA) solvent, was not affected by flue gas contaminants O₂ (≈3 percent), NO₂ (66 ppmv), and SO₂ (145 ppmv).
- The feasibility of utilizing the PEEK HFC for CO₂-loaded solvent regeneration has been established and high CO₂ stripping flux, one order of magnitude higher than CO₂ absorption flux, have been achieved. The economic evaluation based on the membrane absorber and membrane desorber laboratory test data indicate that the CO₂ capture costs can be 25 percent lower than DOE's benchmark amine absorption technology.
- A bench-scale system utilizing a membrane absorber and desorber was integrated into a continuous CO₂ capture process using contactors containing 10–20 ft² of membrane area. The integrated process operation was stable through a 100-hour laboratory test, utilizing a simulated flue gas stream. Greater than 90 percent CO₂ capture combined with 97 percent CO₂ product purity was achieved throughout the test.
- Membrane contactor modules have been scaled from bench scale 2-inch diameter by 12-inch long (20 ft² membrane surface area) modules to 4-inch diameter by 60-inch long pilot scale modules (165 ft² membrane surface area). 4-inch diameter modules were tested in an integrated absorption/regeneration system for CO₂ capture field tests at a coal-fired power plant (Midwest Generation's Will County Station located in Romeoville, IL).
- Absorption and regeneration contactors were constructed utilizing high performance super-hydrophobic, nano-porous PEEK membranes with CO₂ gas permeance of 2,000 GPU and a 1,000 GPU, respectively.
- The economic evaluation based on field tests data indicates that the CO₂ capture cost associated with membrane contactor technology is \$47.50 (YR 2011\$)/tonne of CO₂ captured (No TS&M) when using aMDEA as a solvent.
- Completed preliminary design package for the pilot plant.
- GTI making arrangements with modular skid fabricators for development of the 0.5 MWe membrane pilot unit; discussions with Southern Company Services on testing of the unit at the National Carbon Capture Center.
- PoroGen has manufactured 8-inch elements to be used with activated MDEA and has begun shipping the modules to GTI for performance validation testing.

next steps

- Performance testing of 8-inch elements at GTI will be performed with CO₂ and air to provide the necessary throughput.
- Fabrication and installation of pilot-scale unit.

available reports/technical papers/presentations

Post-Combustion CO₂ Capture Using PEEK Hollow-Fiber-Membrane Contactors, July 2014.

<http://www.netl.doe.gov/File%20Library/Research/Coal/carbon%20capture/post-combustion/ICOM-2014-PEEK-1.pdf>.

Development of Porous PEEK® Hollow Fiber-Based Gas/Liquid Membrane Contactors for Sour Gas Treating.

<http://www.netl.doe.gov/File%20Library/Research/Coal/carbon%20capture/post-combustion/LRGCC-2014-Leppin-Final.pdf>.

“Pilot Test of a Nanoporous, Super-Hydrophobic Membrane Contactor Process for Post-Combustion CO₂ Capture,” presented by S. James Zhou, Gas Technology Institute, 2014 NETL CO₂ Capture Technology Meeting, Pittsburgh, PA, July 2014.

<http://www.netl.doe.gov/File%20Library/Events/2014/2014%20NETL%20CO2%20Capture/S-James-Zhou-GTI-Nanoporous-Super-Hydrophobic-Membrane.pdf>.

“Hollow-Fiber-Membrane Contactors for CCS on Natural Gas Power Systems,” Workshop on Technology Pathways Forward for Carbon Capture and Storage on Natural Gas Power Systems, Washington, DC, April 2014.

<http://www.netl.doe.gov/File%20Library/Research/Coal/carbon%20capture/post-combustion/USEA-NGCC-CCS.pdf>.

“Pilot Test of a Nanoporous, Super-Hydrophobic Membrane Contactor Process for Post-Combustion CO₂ Capture,” Factsheet, February 2014. <http://www.netl.doe.gov/File%20Library/Research/Coal/carbon%20capture/post-combustion/FE0012829.pdf>.

“Pilot Test of a Nanoporous, Super-Hydrophobic Membrane Contactor Process for Post-combustion CO₂ Capture,” Project Kick-Off Presentation, November 2013. <http://www.netl.doe.gov/File%20Library/Research/Coal/ewr/co2/Kickoff-Meeting-DE-FE0012829.pdf>.

Zhou, J., et al., “Hybrid Membrane/Absorption Process for Post-Combustion CO₂ Capture,” presented at the 2013 NETL CO₂ Capture Technology Meeting, Pittsburgh, PA, July 2013.
<http://www.netl.doe.gov/File%20Library/Events/2013/CO2%20Capture/SJ-Zhou-GTI-Membrane-Absorption-Process.pdf>.

Zhou, J., et al., “Hybrid Membrane/Absorption Process for Post-Combustion CO₂ Capture (Membrane Contactor),” presented at the 2012 NETL CO₂ Capture Technology Meeting, Pittsburgh, PA, July 2012.
<http://www.netl.doe.gov/File%20Library/Research/Coal/ewr/co2/J-Zhou-GTI-Hybrid-Membrane-Process.pdf>

Li, S., et al., “Hybrid Membrane/Absorption Process for Post-Combustion CO₂ Capture (Membrane Contactor),” presented at the 2011 NETL CO₂ Capture Technology Meeting, Pittsburgh, PA, August 2011.
<http://www.netl.doe.gov/File%20Library/Research/Coal/ewr/co2/22Aug11-Li-GTI-Hybrid-Membrane-Absorption-Process.pdf>

Zhou, J., et al., “Hybrid Membrane/Absorption Process for Post-Combustion CO₂ Capture (Membrane Contactor),” presented at the 2010 NETL CO₂ Capture Technology Meeting, Pittsburgh, PA, September 2010.
<http://www.netl.doe.gov/File%20Library/Research/Coal/ewr/co2/Shaojun-Zhou---Gas-Technology-Institute.pdf>

BENCH-SCALE DEVELOPMENT OF A HYBRID MEMBRANE-ABSORPTION CO₂ CAPTURE PROCESS

primary project goals

Membrane Technology & Research, Inc. (MTR) is designing, optimizing, building, and testing a bench-scale process for a novel hybrid membrane-amine absorption carbon dioxide (CO₂)-capture system to establish the technical and economic feasibility of using this technology for post-combustion capture of CO₂ to achieve an overall reduction in CO₂ capture cost.

technical goals

- Develop simulation and techno-economic analysis of the combined membrane-absorption system.
- Design and build a large-area plate-and-frame membrane capture system.
- Optimize the UT Austin piperazine-based capture systems for the unique flue gas properties and removal conditions of the hybrid system.
- Install combined membrane-absorption integrated unit and complete parametric testing on hybrid parallel design to optimize the combined process.
- Collect data from combined system testing to refine process simulation and complete final techno-economic analysis.

technical content

MTR is designing and building a bench-scale process for a novel hybrid membrane-absorption CO₂-capture system. The membrane system is based upon the use of low pressure drop, large-area plate-and-frame membrane modules developed by MTR. The solvent system is based on a piperazine solvent blend using an advanced flash stripper developed by UT Austin. Two configurations of the hybrid capture process are being investigated; hybrid-series (Figure 1) and hybrid parallel (Figure 2). Based on process modeling results, the preferred hybrid configuration will be tested at UT Austin's 0.1-MWe SRP Pilot Plant. Parametric testing of the combined bench-scale unit will provide data to optimize the hybrid process and evaluate integration for scaleup.

The hybrid series configuration, shown in Figure 1, consists of the advanced piperazine based absorption unit designed to handle the enriched (>20 percent CO₂) flue gas and remove approximately 50–70 percent of the CO₂, followed by additional separation in the selective recycle membrane where air sweep carries CO₂ back to the boiler. The system is currently modeled for 90 percent carbon capture and has the potential for cost savings over the current MEA-based solvent technology. In the hybrid series configuration, the capital cost of the absorption unit is not expected to change significantly, however the relaxed stripper operating conditions result in energy savings as well as energy and capital expense savings in the CO₂ compression due to higher stripper pressure.

technology maturity:

Bench-Scale, Simulated Flue Gas

project focus:

Hybrid Membrane, Amine Absorption

participant:

Membrane Technology and Research, Inc.

project number:

FE0013118

NETL project manager:

Morgan Mosser
morgan.mosser@netl.doe.gov

principal investigator:

Brice Freeman
Membrane Technology and Research, Inc.
brice.freeman@mtrinc.com

partners:

University of Texas at Austin

performance period:

10/1/13 – 9/30/17

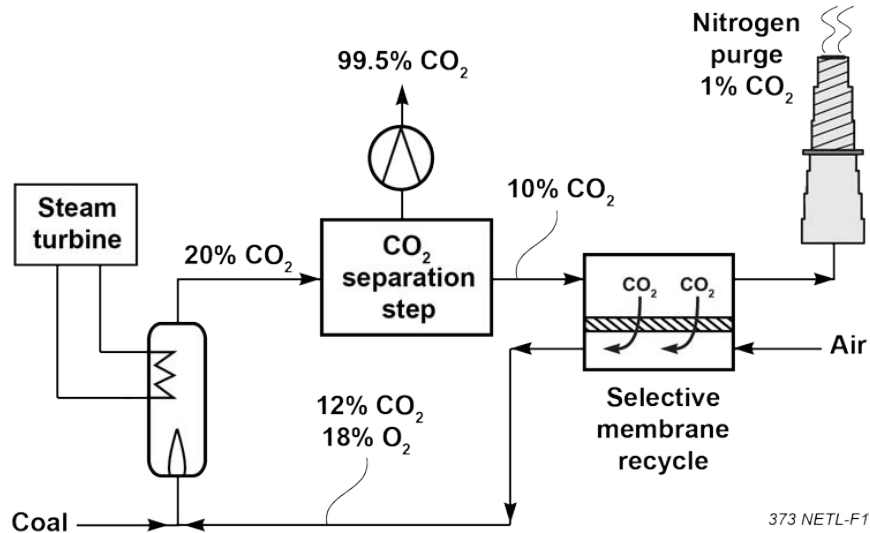

Figure 1: Hybrid Series Carbon Capture System

The hybrid parallel configuration, shown in Figure 2, splits the enriched flue gas flow for treatment in both units in parallel. Opportunities for significant savings in capital cost arise from the reduction in size of the absorption unit due to the reduced volume of gas being treated. Energy savings come from treating flue gas with a higher concentration of CO₂.

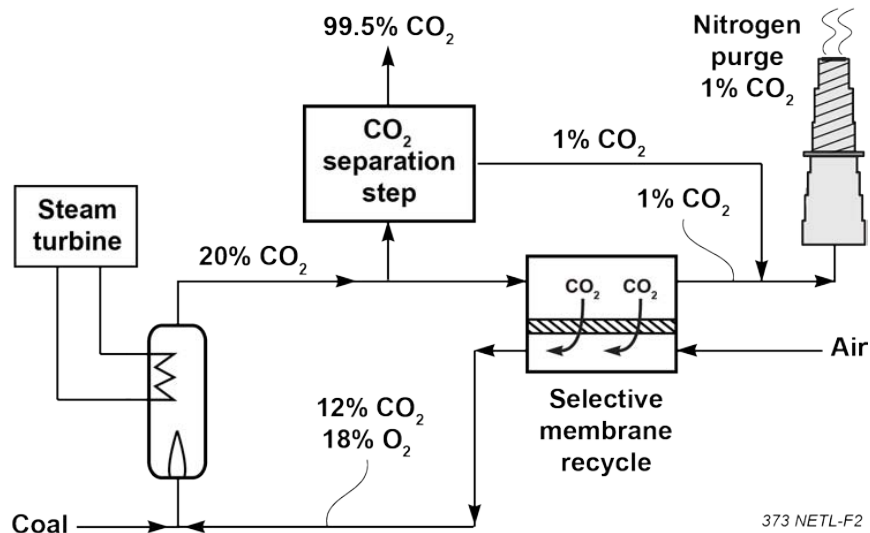

Figure 2: Hybrid Parallel Carbon Capture System

Modeling results indicate that the hybrid parallel configuration offers the most potential for cost savings. The membrane and process parameters identified to date, for the hybrid parallel configuration, are provided in Table 1. The solvent and process parameters identified to date are provided in Table 2.

TABLE 1: MTR MEMBRANE PARAMETERS

	Units	Current R&D Value	Target R&D Value
Materials Properties			
Materials of Fabrication for Selective Layer		proprietary polymer	
Materials of Fabrication for Support Layer		proprietary polymer	
Nominal Thickness of Selective Layer	μm	<1	<1
Membrane Geometry		plate-and-frame	plate-and-frame
Max Trans-Membrane Pressure	bar	70	70
Hours Tested Without Significant Degradation		500	500
Manufacturing Cost for Membrane Material	\$/m ²	100	10
Membrane Performance			
Temperature	°C	30	30
CO ₂ Pressure Normalized Flux	GPU or equivalent	1,500	>2,500
CO ₂ /H ₂ O Selectivity	—	0.5	0.5
CO ₂ /N ₂ Selectivity	—	50	50
CO ₂ /SO ₂ Selectivity	—	0.5	0.5
Type of Measurement	—	pure gas	pure gas
Proposed Module Design		<i>(for equipment developers)</i>	
Flow Arrangement	—	cross-flow, partial countercurrent	
Packing Density	m ² /m ³	1,000	
Shell-Side Fluid	—	N/A	
Flue Gas Flowrate	kg/hr	5,000	
CO ₂ Recovery, Purity, and Pressure	%%/bar	90%, >96%, 140 bar	
Pressure Drops Shell/Tube Side	bar	feed: 0.1; sweep:0.2	

Definitions:

Membrane Geometry – Flat discs or sheets, hollow fibers, tubes, etc.

Pressure Normalized Flux – For materials that display a linear dependence of flux on partial pressure differential, this is equivalent to the membrane's permeance.

GPU – Gas Permeation Unit, which is equivalent to 10⁻⁶ cm³ (1 atm, 0 °C)/cm²/s/cm Hg. For non-linear materials, the dimensional units reported should be based on flux measured in cm³ (1 atm, 0 °C)/cm²/s with pressures measured in cmHg.

Note: 1 GPU = 3.3464 × 10⁻⁶ kg mol/m²-s-kPa [SI units].

Type of Measurement – Either mixed or pure gas measurements; target permeance and selectivities should be for mixture of gases found in de-sulfurized flue gas.

Flow Arrangement – Typical gas-separation module designs include spiral-wound sheets, hollow-fiber bundles, shell-and-tube, and plate-and-frame, which result in either co-current, counter-current, cross-flow arrangements, or some complex combination of these.

Packing Density – Ratio of the active surface area of the membrane to the volume of the module.

Shell-Side Fluid – Either the permeate (CO₂-rich) or retentate (flue gas) stream.

Proposed Module Design – Assume the module is located after the flue gas desulfurization (FGD), and that flue gas pressure is 14.7 psia, temperature is 135 °F, and composition (wet basis) are:

Composition (% vol)					Composition (ppmv)	
CO ₂	H ₂ O	N ₂	O ₂	Ar	SO _x	NO _x
23.16	6.11	68.34	1.60	0.79	42	74

Other Parameter Descriptions:

Membrane Permeation Mechanism – MTR’s polymeric membranes permeate CO₂ via a solution diffusion mechanism. The combustion air sweep (ambient air) contains very little CO₂ (400 ppm). The difference in CO₂ partial pressure of the two streams passing through the membrane contactor (CO₂ enriched flue gas and the sweep gas) provides the necessary driving force to permeate CO₂. No additional feed compression or permeate vacuum is required.

Contaminant Resistance – The membranes are known to be unaffected by water (H₂O), oxygen (O₂), and sulfur dioxide (SO₂). The effect of trace contaminants, such as mercury, arsenic, etc., is unknown and is being examined in the ongoing field demonstration at the National Carbon Capture Center (NCCC) in Wilsonville, AL, under a different U.S. Department of Energy National Energy Technology Laboratory (DOE/NETL)-sponsored project (DE-FE0005795).

Flue Gas Pretreatment Requirements – Currently, pretreatment requirements are unknown. The current demonstration tests at NCCC treat post-flue gas desulfurization (FGD) flue gas and will help determine the need for gas treatment prior to entering the membrane system. The greatest concern of species present in flue gas is that particulate matter will foul the membranes, reducing module lifetimes. MTR’s membrane modules have operated in excess of 8000 hours on flue gas at NCCC with no appreciable plugging effect. Particulate filters that can achieve an order of magnitude better ash removal than a standard bag house, and are used today to treat refinery and gasification streams, may be needed.

Waste Streams Generated – The membrane process will recover >95 percent of the H₂O in flue gas as liquid. The quality of this H₂O and its potential to be reused in the plant will be studied in future work.

TABLE 2: MTR SOLVENT PARAMETERS

	Units	Current R&D Value	Target R&D Value
Pure Solvent			
Molecular Weight	mol ⁻¹	86	103
Normal Boiling Point	°C	146	150
Normal Freezing Point	°C	106	80
Vapor Pressure at 15 °C	bar	0.000206	0.0002
Manufacturing Cost for Solvent	\$/kg	2	6
Working Solution			
Concentration	kg/kg	0.3	0.33
Specific Gravity (15 °C/15 °C)	—	1.029	1.03
Specific Heat Capacity at STP	kJ/kg-K	3.2	3.3
Viscosity at STP	cP	7	8
Absorption			
Pressure	bar	0.1	0.1
Temperature	°C	40	40
Equilibrium CO ₂ Loading	mol/mol	0.8	0.9
Heat of Absorption	kJ/mol CO ₂	70	70
Solution Viscosity	cP	4	5

TABLE 2: MTR SOLVENT PARAMETERS (CONTINUED)

	Units	Current R&D Value	Target R&D Value
Desorption			
Pressure	bar	5	5
Temperature	°C	150	150
Equilibrium CO ₂ Loading	mol/mol	0.44	0.4
Heat of Desorption	kJ/mol CO ₂	70	70
Proposed Module Design		<i>(for equipment developers)</i>	
Flue Gas Flowrate	kg/hr		
CO ₂ Recovery, Purity, and Pressure	%%/bar		
Absorber Pressure Drop	bar		

Definitions:

STP – Standard Temperature and Pressure (15 °C, 1 atm).

Pure Solvent – Chemical agent(s), working alone or as a component of a working solution, responsible for enhanced CO₂ absorption (e.g., the amine MEA in an aqueous solution).

Manufacturing Cost for Solvent – “Current” is market price of chemical, if applicable; “Target” is estimated manufacturing cost for new solvents, or the estimated cost of bulk manufacturing for existing solvents.

Working Solution – The solute-free (i.e., CO₂-free) liquid solution used as the working solvent in the absorption/desorption process (e.g., the liquid mixture of MEA and water).

Absorption – The conditions of interest for absorption are those that prevail at maximum solvent loading, which typically occurs at the bottom of the absorption column. These may be assumed to be 1 atm total flue-gas pressure (corresponding to a CO₂ partial pressure of 0.13 bar) and 40 °C; however, measured data at other conditions are preferable to estimated data.

Desorption – The conditions of interest for desorption are those that prevail at minimum solvent loading, which typically occurs at the bottom of the desorption column. Operating pressure and temperature for the desorber/stripper are process-dependent (e.g., an MEA-based absorption system has a typical CO₂ partial pressure of 1.8 bar and a reboiler temperature of 120 °C). Measured data at other conditions are preferable to estimated data.

Pressure – The pressure of CO₂ in equilibrium with the solution. If the vapor phase is pure CO₂, this is the total pressure; if it is a mixture of gases, this is the partial pressure of CO₂. Note that for a typical PC power plant, the total pressure of the flue gas is about 1 atm and the concentration of CO₂ is about 13.2 percent. Therefore, the partial pressure of CO₂ is roughly 0.132 atm or 0.130 bar.

Concentration – Mass fraction of pure solvent in working solution.

Loading – The basis for CO₂ loadings is moles of pure solvent.

Other Parameter Descriptions:

Chemical/Physical Solvent Mechanism – Chemical solvent.

Solvent Contaminant Resistance – Excellent resistance to oxidation, thermally resistant to 150 °C.

Solvent Foaming Tendency – Little to none.

Flue Gas Pretreatment Requirements – SO₂ removal by FGD and flue gas cooling with a direct contact cooler.

Solvent Makeup Requirements – <0.2 kg solvent per tonne of CO₂ captured.

Waste Streams Generated – Waste solution and sludge from thermal reclaiming of the solvent.

Process Design Concept – See Figure 3 below illustrating the advanced flash stripper (AFS) process featuring cold- and warm-rich bypass. The solvent will be regenerated by the advanced flash stripper.

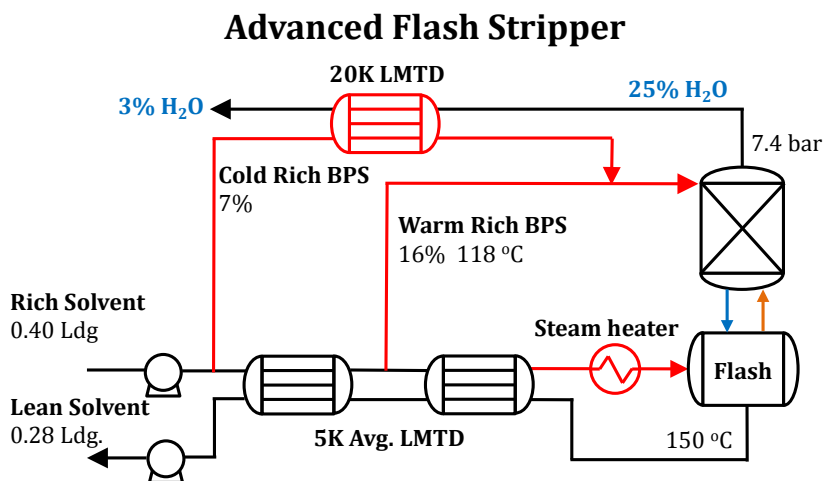

Figure 3: Advanced Flash Stripper for Solvent Regeneration

technology advantages

- The use of the membrane sweep recycle significantly increases CO₂ concentration in flue gas.
- Use of less concentrated piperazine solvent blends avoids lean and rich precipitation issues observed with a more concentrated solvent (e.g., 8 m PZ) while maintaining similar absorption rate, lower viscosity, better mass transfer in absorber, and reduced approach temperature in the cross heat exchanger.
- Hybrid series system:
 - Reduced removal requirements for absorption unit.
 - Energy of stripping step reduced.
 - Energy and CapEx of CO₂ compression reduced.
- Hybrid parallel system.
 - Reduced volume of flue gas to absorption unit.
 - CapEx of absorber much reduced due to decreased flow to be treated.
- Preliminary calculations suggest energy cost of carbon capture could be reduced by 30 percent compared to MEA-based system.

R&D challenges

- CO₂ concentration in flue gas in hybrid series configuration is limited by the boiler O₂ concentration requirement in the sweep air stream.
- High solvent lean loading conditions lead to high solvent circulation rates and increased heat and mass transfer requirements, increasing costs.
- 5 m PZ showed only marginal rich loading improvements at higher CO₂ concentrations in the flue gas; new thermally stable, high capacity, piperazine solvent blends are being investigated.

results to date/accomplishments

- Initial process modelling of hybrid series and parallel system configurations completed.
- Identified hybrid-parallel configuration to be superior to hybrid-series configuration.
- Manufactured large area membrane rolls.
- Large area plate-and-frame membrane module sized and designed.

next steps

- Prepare updated model runs using higher absorber removal rates (95 percent and 99 percent), and for normal and over-stripped lean loadings.
- Prepare updated model runs using higher capacity solvent (5 m PZ/5 m MDEA).
- Prepare low pressure drop, 500 m² plate-and-frame skid to be used for testing.
- Modify the UT Austin SRP Pilot Plant for addition of third section of packing and water wash section.

available reports/technical papers/presentations

“Bench-Scale Development of a Hybrid Membrane-Absorption CO₂ Capture Process,” Presented by Brice Freeman, Membrane Technology and Research, Inc., 2014 NETL CO₂ Capture Technology Meeting, Pittsburgh, PA, July 2014.

http://www.netl.doe.gov/File_Library/Events/2014/2014_NETL_CO2_Capture/B-Freeman-MTR-Bench-Hybrid-Absorption-Membrane.pdf.

Bench-Scale Development of a Hybrid Membrane-Absorption CO₂ Capture Process,” Project Kick-Off Meeting Presentation, December 20, 2013. http://www.netl.doe.gov/File_Library/Research/Coal/ewr/Kickoff-Presentation-fe0013118.pdf.

SUPERSONIC POST-COMBUSTION INERTIAL CO₂ EXTRACTION SYSTEM

primary project goals

Orbital ATK is designing an inertial carbon dioxide (CO₂) extraction system (ICES) on the bench scale that converts the CO₂ in flue gas to solid CO₂ using supersonic expansion followed by inertial separation. The project aims to demonstrate an overall reduction in total carbon capture cost for post combustion CO₂ capture consistent with DOE Carbon Capture program performance goals.

technical goals

- Demonstrate inertial CO₂ extraction system at the bench scale including condensation, migration, CO₂ removal, and diffusion of the CO₂-depleted flue gas to atmospheric pressure.
- Develop approach to obtain condensed CO₂ particle size required for effective migration and separation.
- Demonstrate pressure recovery efficiency of system consistent with economic goals.
- Demonstrate CO₂ capture efficiency.
- Update techno-economic analysis to show path to meeting DOE CO₂ capture goals.

technical content

Orbital ATK is designing an inertial CO₂ extraction system (ICES) to achieve an overall reduction in total carbon capture cost for post combustion CO₂ capture. The ICES system, shown in Figure 1, is based on supersonic inertial separation technology. Compressed flue gas undergoes supersonic expansion (high velocity, low pressure and temperature), which results in CO₂ desublimation. Turning the supersonic flow in the curved flow path causes inertial separation of the dense, solid CO₂ particles, which are collected in a CO₂ rich stream through a duct in the wall into a cyclone separator where the CO₂ solids are collected. The CO₂-depleted stream is diffused and sent to the stack.

Factors for improved performance of the ICES system include controlling and increasing CO₂ particle size to increase migration and capture, recirculation of a fraction of the collected liquid CO₂ to promote additional cooling and heterogeneous nucleation for larger particles, and efficient pressure recovery. Testing is planned to address these topics. The compact design, along with efficiencies in CO₂ capture, reduces costs of the carbon capture system. An initial techno-economic assessment by Worley Parsons estimated a \$41.80 cost/ton CO₂ captured for an ICES plant, with cost savings coming from lower capital costs (smaller equipment), lower operating costs (no moving parts, chemicals or media), and improved capture efficiency compared to a typical amine solvent-based plant.

technology maturity:

**Bench-Scale, Simulated
Flue Gas**

project focus:

**Supersonic Inertial CO₂
Extraction System**

participant:

Orbital ATK Inc.

project number:

FE0013122

NETL project manager:

Andrew O’Palko
andrew.opalko@netl.doe.gov

principal investigator:

Vladimir Balepin
Orbital ATK Inc.
vladimir.balepin@orbitalatk.com

partners:

**ACENT Laboratories,
The Ohio State
University,
Electric Power Research
Institute**

performance period:

10/1/13 – 9/30/16

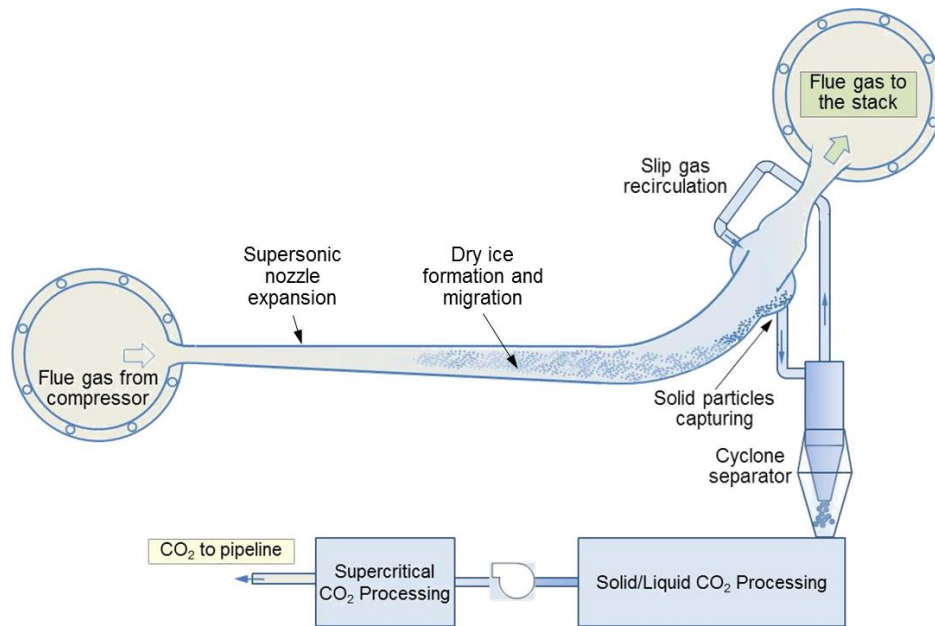

Figure 1: ICES System

Scaling the technology for use in a full scale power plant involves combining multiple ICES units for increased capacity. The compactness of the group of ICES units, as shown in the proposed plant configuration in Figure 2, leads to substantial reductions in the footprint capture plant compared to a similar capacity capture plant using amine solvent capture technology (8,000 m² vs. 20–30,000 m²). Stacking the ICES nozzles and compressors further reduces the footprint.

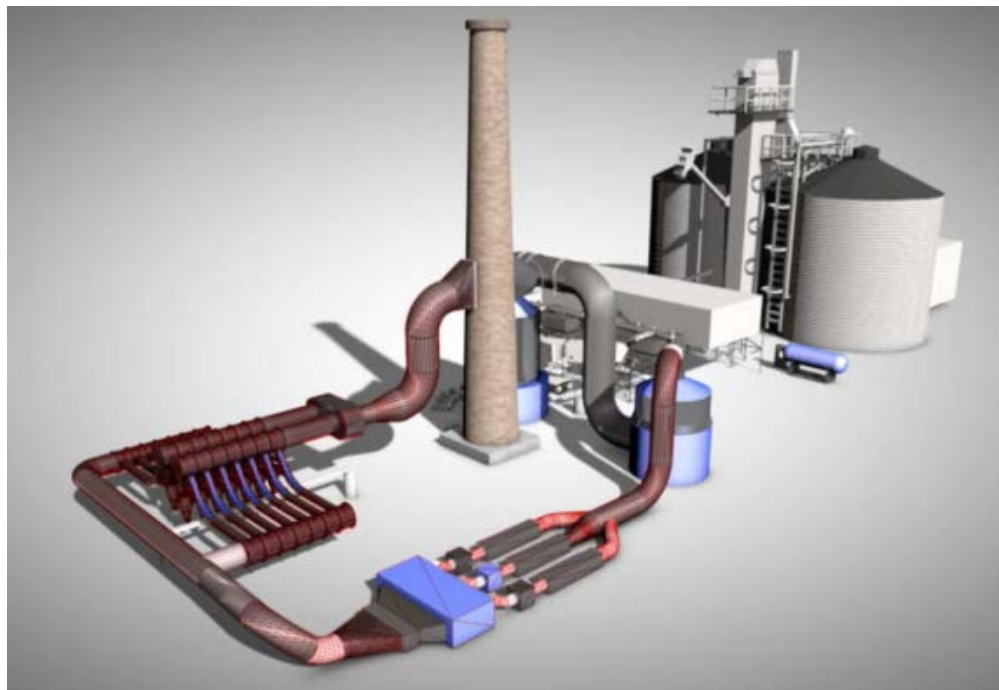

Figure 2: ICES Installation in Power Plant

technology advantages

- No moving parts, chemicals/additives, or consumable media.
- No refrigeration expense—low temperatures from supersonic expansion.
- Inexpensive construction based on sheet metal and concrete.
- Small equipment footprint.
- “Cold sink” available from accumulated solid CO₂.
- Costs driven by flue gas compression.

R&D challenges

- Development of optimized supersonic contour to maximize particle size and migration and minimize pressure losses.
- Minimization of slip gas that is removed with CO₂.
- CO₂ purity—condensable flue gas impurities removed along with CO₂.
- Solid CO₂ processing.
- Optimization of flow path pressure recovery.

results to date/accomplishments

- Particle size diagnostic has been demonstrated and calibrated.
- Completed CO₂ particle growth testing and complementary modeling to determine factors controlling particle size and methods to increase.
- Preliminary CO₂ capture results indicate good to excellent performance when incoming temperatures are somewhat colder.
- CFD tool benchmarking using subscale test results show traceability and path to ICES system pressure recovery of no less than 40 percent.

next steps

- Bench-scale parametric testing with surrogate flue gas (air, CO₂, water).
- Update techno-economic assessment based on newly developed ICES process.

available reports/technical papers/presentations

“Supersonic Post-Combustion Inertial CO₂ Extraction System,” Presented by Tony Castrogiovanni, ATK, 2014 NETL CO₂ Capture Technology Meeting, Pittsburgh, PA, July 2014.

<http://www.netl.doe.gov/File%20Library/Events/2014/2014%20NETL%20CO2%20Capture/A-Castrogiovanni-ATK-Supersonic-Post-Combustion.pdf>

“Supersonic Post-Combustion Inertial CO₂ Extraction System,” Kick-Off Presentation, November 2013.

<http://www.netl.doe.gov/File%20Library/Research/Coal/carbon%20capture/post-combustion/11-14-2013-NETL-ICES-Kickoff-Nonproprietary.pdf>

CO₂ CAPTURE BY COLD MEMBRANE OPERATION WITH ACTUAL COAL-FIRED POWER PLANT FLUE GAS

primary project goals

Air Liquide is developing a novel carbon dioxide (CO₂) capture process by combining commercial hollow fiber membrane bundles with cryogenic separation technology. A 0.3-MWe field test unit is being designed and constructed to demonstrate the technical and economic feasibility of using this technology for post-combustion capture of CO₂ to achieve an overall reduction in CO₂ capture cost.

technical goals

- Computational fluid dynamics (CFD) modeling to guide improvement in 12" PI-1 membrane bundle performance.
- Fabricate improved configuration bundles and test on bench-scale with synthetic flue gas.
- High permeance PI-2 fiber spinning and testing with synthetic flue gas
- Develop a detailed design package for the 0.3-MWe field test unit.
- Install and commission the field test unit at the National Carbon Capture Center (NCCC) for PI-1 and PI-2 membrane testing.
- Steady state testing of the field test unit with coal-derived flue gas for 500 hours to verify process operability.
- Complete a techno-economic analysis to evaluate potential to meet carbon capture cost targets.

technical content

Air Liquide is developing a novel, cost-effective CO₂ capture technology by combining the use of commercial hollow fiber membrane bundles with cryogenic operation to selectively remove the CO₂ from flue gas. For most membrane materials, permeability decreases and selectivity increases with a decrease in operating temperature. However, laboratory measurements of the Air Liquide membranes operated at temperatures below -20 °C show two to four times higher CO₂/nitrogen (N₂) selectivity with minimal loss of CO₂ permeance compared to ambient temperature values.

Figure 1 presents a simplified block diagram of the cold membrane process. A highly selective cold membrane provides pre-concentration of CO₂ prior to CO₂ partial condensation in a liquefaction unit. The cryogenic heat exchanger system provides energy integration between the membrane and the CO₂ liquefaction system.

technology maturity:

Bench-Scale, Simulated Flue Gas, Actual Flue Gas Slipstream (0.3 MWe)

project focus:

Subambient Temperature Membrane

participant:

American Air Liquide, Inc.

project number:

FE0013163, FE0004278

NETL project manager:

José Figueroa
jose.figueroa@netl.doe.gov

principal investigator:

Trapti Chaubey
American Air Liquide
trapti.chaubey@airliquide.com

partners:

Air Liquide Engineering
Air Liquide – MEDAL
Parsons Government Services, Inc.

performance period:

10/1/10 – 3/31/16

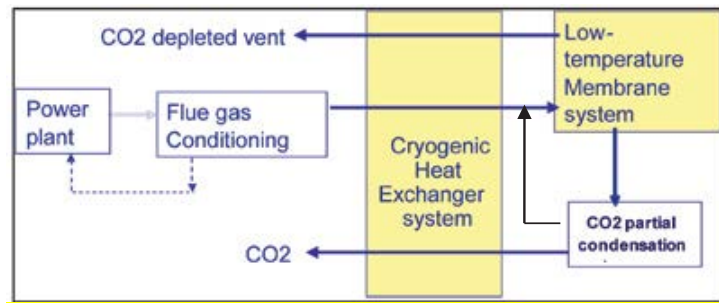

Figure 1: Block Diagram of Cold Membrane

Figure 2 shows a schematic diagram of the hybrid cold membrane process. The process lines in Figure 2 are color-coded (black for ambient temperature; dark blue for approximately -30 °C; and light blue for approximately -50 °C). The pre-treated flue gas is compressed to approximately 230 psi (16 bar). The heat of compression is captured in boiler feed water, raising its temperature to approximately 147 °C. The compressed flue gas is then dried in a dehydration unit to prevent water condensation when the stream is cooled in the brazed aluminum heat exchanger to approximately -40 °C. The cooled, dried, compressed flue gas is then fed to the membrane to produce a residue stream with approximately 1.8 percent CO₂ at approximately 215 psi (15 bar) and a permeate stream with 60–70 percent CO₂ at approximately 17 psi (1–2 bar). After the residue is sent through the heat exchanger, further cooling and energy recovery is done via a series of turbo-expanders with the resulting stream at -57 °C. The cold stream is again sent through the heat exchanger to provide cold for the overall process. Finally, the excess pressure energy remaining in the warmed residue is partly recovered in a warm turbo-expander before venting. A fraction of the vent gas is used to regenerate the drier. The permeate stream is recompressed, cooled in the heat exchanger, and undergoes phase separation in the cryo-phase separator. Liquid CO₂ is pumped from the separator to provide a sequestration-ready product CO₂ at approximately 870 psi (60 bar), or greater, and 20 °C. The overhead from the cryo-phase separator is warmed through the heat exchanger and then undergoes energy recovery in a turbo-expander. This stream is mixed with the incoming dried flue gas, which raises the mixed feed concentration entering the membrane to 18 percent CO₂. The higher CO₂ content improves the membrane separation.

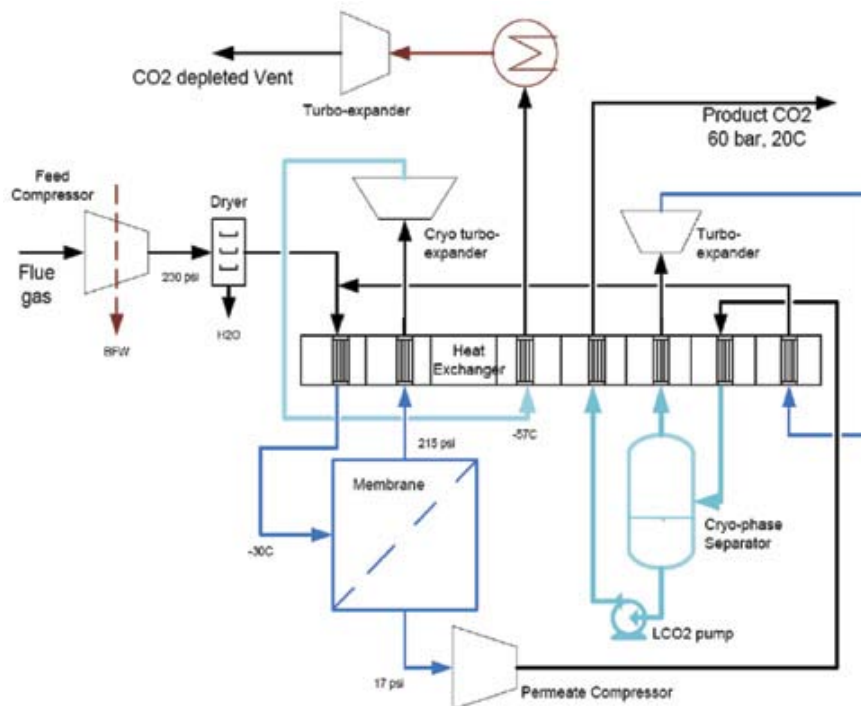

Figure 2: Schematic Diagram of Cold Membrane Process

Fabrication and installation of the 0.3-MWe field test unit at NCCC allows for parametric testing and long-term continuous runs on the optimized PI-1 membrane modules as well as the advanced high-permeance PI-2 membrane modules. Dynamic tests to quantify the performance of the carbon capture system provide data for a final techno-economic analysis for a 550-MWe power plant with optimized membrane bundles to assess the system’s ability to reach the targets of >90 percent CO₂ capture and >95 percent purity at a capture cost approaching \$40/tonne.

The membrane and process parameters identified to date are provided in Table 1.

TABLE 1: AIR LIQUIDE MEMBRANE PARAMETERS

	Units	Current R&D Value	Target R&D Value
Materials Properties			
Materials of Fabrication for Selective Layer	—	Polyimide	Polyimide
Materials of Fabrication for Support Layer	—	Polyimide	Polyimide
Nominal Thickness of Selective Layer	µm	<0.1 µm	<0.1 µm
Membrane Geometry	—	Hollow Fiber	Hollow Fiber
Max Trans-Membrane Pressure	bar	20	20
Hours Tested Without Significant Degradation	—	Single 6-inch bundle tested for >5,500 hours, Single 12-inch bundle tested for >2,400 hours with synthetic flue gas	500 hours on actual flue gas
Manufacturing Cost for Membrane Material	\$/m ²	20	20
Membrane Performance			
Temperature	°C	-30 °C to -45 °C	-30 °C to -45 °C
CO ₂ Pressure Normalized Flux	GPU or equivalent	>455 Nm ³ /hr of bundle productivity for 12-inch PI-1 bundle	>455 Nm ³ /hr of bundle productivity for 12-inch PI-1 bundle
CO ₂ /H ₂ O Selectivity	—	<0.2 (Dry Gas)	<0.2 (Dry Gas)
CO ₂ /N ₂ Selectivity	—	>70	>70
CO ₂ /SO ₂ Selectivity	—	0.3	0.3
Type of Measurement	—	12" bundle parametric and long-term testing with synthetic flue gas	12" bundle parametric and long-term testing with actual flue gas
Proposed Module Design		<i>(for equipment developers)</i>	
Flow Arrangement	—	Hollow Fiber	
Packing Density	m ² /m ³	>3,000 m ² /m ³	
Shell-Side Fluid	—	CO ₂ rich permeate	
Flue Gas Flowrate	kg/hr	>455 Nm ³ /hr/12 inch bundle	
CO ₂ Recovery, Purity, and Pressure	%/%/bar	90%, >95% purity in hybrid process (>60% CO ₂ purity from membrane), 60 bar	
Pressure Drops Shell/Tube Side	bar	0.1 bar shell side/1 bar tube side	

Definitions:

Membrane Geometry – Flat discs or sheets, hollow fibers, tubes, etc.

Pressure Normalized Flux – For materials that display a linear dependence of flux on partial pressure differential, this is equivalent to the membrane’s permeance.

GPU – Gas Permeation Unit, which is equivalent to 10⁻⁶ cm³ (1 atm, 0 °C)/cm²/s/cm Hg. For non-linear materials, the dimensional units reported should be based on flux measured in cm³ (1 atm, 0 °C)/cm²/s with pressures measured in cm Hg.

Note: 1 GPU = 3.3464×10⁻⁶ kg mol/m²-s-kPa [SI units]. Bundle productivity in terms of feed flow rate in Nm³/hr is reported.

Type of Measurement – Either mixed or pure gas measurements; target permeance and selectivities should be for mixture of gases found in de-sulfurized flue gas.

Flow Arrangement – Typical gas-separation module designs include spiral-wound sheets, hollow-fiber bundles, shell-and-tube, and plate-and-frame, which result in either cocurrent, countercurrent, crossflow arrangements, or some complex combination of these.

Packing Density – Ratio of the active surface area of the membrane to the volume of the module.

Shell-Side Fluid – Either the permeate (CO₂-rich) or retentate (flue gas) stream.

Estimated Cost – Basis is kg/hr of CO₂ in CO₂-rich product gas; assuming targets are met.

**Proposed Module Design Assumptions* – Assume the module is located after the flue gas desulfurization (FGD), and that flue gas pressure is 14.7 psia, temperature is 135 °F, and composition (wet basis) are:

Composition(%vol)					Composition(ppmv)	
CO ₂	H ₂ O	N ₂	O ₂	Ar	SO _x	NO _x
13.17	17.25	66.44	2.34	0.80	42	74

Other Parameter Descriptions:

Membrane Permeation Mechanism –Nominally based on solution-diffusion.

Contaminant Resistance –Expected to be resistant to acidic components based on experience to date.

Flue Gas Pretreatment Requirements –Particulate removal and acid component removal to meet compressor specifications, dehydration to meet cold box specifications, mercury (Hg) removal to meet heat exchanger specification.

Membrane Replacement Requirements –Membrane productivity decline was too small to be quantified in bench-scale test with synthetic gases.

Waste Streams Generated –Acidic water.

Process Design Concept –Flow sheet/block flow diagram, if not included above

technology advantages

- Subambient operation improves membrane performance.
- Process design provides partial recovery of the flue gas compression energy.
- Process design provides an economic method of cooling the flue gas feed to the required sub-ambient temperature for optimal membrane operation without external refrigeration.
- The process design can be combined with a novel scheme for contaminant (SO₂, NO_x) removal.

R&D challenges

- Subambient membrane operation requires development of suitable membrane module materials with adequate permeance and selectivity in a commercial membrane module.
- Long-term membrane module performance stability.
- Integration of subambient membrane process, including energy integration with the CPU, as well as energy integration with the power plant, such as compression and turbo-expansion schemes, heat economizers, and energy conservation.
- Flue gas contaminant-specific challenges, including acid gas (NO_x, SO₂) separation, compressor materials of construction, particulate removal, Hg removal, and water management.
- Novel PI-2 material development must achieve tolerance to operating pressure/temperature, effective epoxy seals, long term stability, and manufacturing reproducibility.

results to date/accomplishments

- Conducted closed-loop, bench-scale testing of 6- and 12-inch diameter membrane bundles (equivalent to 2–2.5 tonnes of CO₂ per day, or 0.1 MW) at the proposed subambient temperature conditions using synthetic flue gas (CO₂ and N₂).
 - The majority of the testing was run at 200 psi, -45 °C, and 18 percent CO₂ feed. Parametric testing was conducted over a broad range of feed conditions: temperature (-25 to -45 °C), pressure (160–200 pounds per square inch gauge [psig]), and CO₂ feed concentration (18–12 percent).
 - Stability of membrane performance at sub-ambient temperature was successfully demonstrated over 8 months; there were no signs of mechanical degradation.
 - The membrane performance was approximately 10 percent lower CO₂/N₂ selectivity and 15 percent higher CO₂ permeance than the estimate based on previous laboratory testing. However, this results in a favorable tradeoff between capital and operating cost: a 7 percent increase in specific energy of capture and 40 percent decrease in membrane surface area.
 - Parametric tests indicated that the membrane performance would be best at the coldest temperature and highest feed pressure that can be achieved.
- Conducted laboratory testing of the membrane using synthetic flue gas (CO₂ and N₂) that contains low concentrations (100 parts per million [ppm]) of SO₂, NO₂, and NO.
 - Both SO₂ and NO₂ are more permeable than CO₂. This implies that these contaminants will be efficiently removed with CO₂ into the membrane permeate. NO permeance is intermediate between CO₂ and N₂; hence, NO concentration is expected to be unchanged by the membrane.
- Completed a techno-economic study of the proposed sub-ambient temperature membrane process.
 - The specific energy estimates for CO₂ capture by this process ranges from 216 to 242 kWh per tonne CO₂ captured.
 - The conceptual membrane design basis for a 550-MW net coal power plant would include 140 duplex bundle housings containing 36-inch diameter x 40-inch long membrane bundles.
 - The energy capture estimate was coupled with capital cost estimates to calculate the levelized cost-of-electricity (LCOE) for 90 percent CO₂ capture from an air-fired, 550-MW net coal power plant. This analysis indicated increases in LCOE between 48 and 53 percent in the previous DOE funded project (DE-FE-0004278). Bundle optimization in the current project has the potential to lower this cost further. An update to the TEA will be conducted during BP2 in the current project.
- Design and fabrication completed for the 0.3-MWe field test unit.
- Conducted CFD modeling to optimize the performance of 12 inch PI-1 bundles by reducing the non-idealities in the membrane. Several parameters such as packing density, fiber performance and permeate pressure etc. were studied to improve the membrane performance.
- Single PI-1 12" membrane modules tested on 0.1-MWe bench-scale unit with simulated flue gas for 2,400 hrs. Optimized PI-1 bundle with sweep mode operation showed >30 percent productivity improvement over non-sweep operation at 90% CO₂ recovery.
- Four 12" PI-1 modules have met the performance target and are qualified for field testing at NCCC. PI-2 mini-permeator membrane test results with simulated flue gas show greater than 5x intrinsic fiber permeance improvement over PI-1 membrane.

next steps

- Acceptance testing of 0.3 MWe field test unit.
- Delivery and installation of field test unit to NCCC.
- Bench-scale testing with simulated gas on 1" PI-2 membrane bundle.
- Field testing of PI-1 and PI-2 membrane modules at NCCC for >500 hours of steady state operation.
- Techno-economic analysis and Environmental, Health and Safety analysis for the cold membrane process.

available reports/technical papers/presentations

“CO₂ Capture by Cold Membrane Operation,” presented by David Hasse, International Conference on Greenhouse Gas Technologies, October 2014. http://www.netl.doe.gov/File_Library/Research/Coal/carbon_capture/post-combustion/fe0013163-ghgt-12-final.pdf.

“CO₂ Capture by Cold Membrane Operation with Actual Coal Fired Power Plant Flue Gas,” presented by TraptiChaubey, Air Liquide, Inc., 2014 NETL CO₂ Capture Technology Meeting, Pittsburgh, PA, July 2014. [http://www.netl.doe.gov/File_Library/Events/2014/2014 NETL CO₂ Capture/T-Chaubey-AL-CO₂-Capture-by-Cold-Membrane-Operation.pdf](http://www.netl.doe.gov/File_Library/Events/2014/2014_NETL_CO2_Capture/T-Chaubey-AL-CO2-Capture-by-Cold-Membrane-Operation.pdf).

“CO₂ Capture by Cold Membrane Operation.” GHGT-12, Energy Procedia, 2013. http://www.netl.doe.gov/File_Library/Research/Coal/carbon_capture/post-combustion/Procedia-GHGT-12-Kulkarni.pdf.

“CO₂ Capture By Subambient Membrane Operation,” Final Report, January 2013.

“CO₂ Capture by Subambient Membrane Operation,” presented by Sudhir Kulkarni, American Air Liquide, Inc., 2012 NETL CO₂ Capture Technology Meeting, Pittsburgh, PA, July 2012. [http://www.netl.doe.gov/File_Library/Research/Coal/ewr/CO₂/S-Kulkarni-AAL-Sub-ambient-Membrane.pdf](http://www.netl.doe.gov/File_Library/Research/Coal/ewr/CO2/S-Kulkarni-AAL-Sub-ambient-Membrane.pdf).

“CO₂ Capture by Subambient Membrane Operation,” presented by Ed Sanders, American Air Liquide, Inc., 2011 NETL CO₂ Capture Technology Meeting, Pittsburgh, PA, August 2011. [http://www.netl.doe.gov/File_Library/Research/Coal/ewr/CO₂/22Aug11-Sanders-AirLiquide-SubAmbient-Membrane-Operation.pdf](http://www.netl.doe.gov/File_Library/Research/Coal/ewr/CO2/22Aug11-Sanders-AirLiquide-SubAmbient-Membrane-Operation.pdf).

“CO₂ Capture by Subambient Membrane Operation,” presented by American Air Liquide, 2010 Annual NETL CO₂ Capture Technology R&D Meeting, Pittsburgh, PA, September 2010. [http://www.netl.doe.gov/File_Library/Research/Coal/ewr/CO₂/Sudhir-Kulkarni---American-Air-Liquide--DRTC-.pdf](http://www.netl.doe.gov/File_Library/Research/Coal/ewr/CO2/Sudhir-Kulkarni---American-Air-Liquide--DRTC-.pdf).

NOVEL INORGANIC/POLYMER COMPOSITE MEMBRANES FOR CO₂ CAPTURE

primary project goals

Ohio State University is developing an inorganic/polymer composite membrane consisting of a thin, selective inorganic-containing layer embedded in a polymer structure. The project includes development of a new membrane design to improve system performance through laboratory- and bench-scale testing and decrease costs through development of a continuous manufacturing process.

technical goals

- Develop membrane synthesis process that incorporates a thin, selective inorganic-containing layer embedded in a polymer structure into spiral-wound modules.
 - Membranes will be developed and down-selected to achieve the DOE target of <\$40/tonne CO captured for 2025 (for a carbon dioxide (CO₂)/nitrogen (N₂) and H₂O/N₂ selectivity of >100 and a CO₂ permeance of >2,500 gas permeation units (GPU)).
 - Continuous fabrication of the proposed hybrid membrane morphology will be performed with the use of a continuous membrane fabrication machine.
- Conduct membrane characterization via bench-scale testing.
 - Functional hybrid membranes will be synthesized for incorporation into three prototype membrane modules for parametric and continuous testing with simulated or actual flue gas.
- Complete system and cost analysis of the membrane system.

technical content

Ohio State University is developing a cost-effective design and manufacturing process for new membrane modules that capture CO₂ from flue gas. The membranes consist of a thin, selective inorganic-containing layer embedded in a polymer structure so that it can be made in a continuous manufacturing process. The membrane will be incorporated in spiral-wound modules for bench-scale tests using coal-fired flue gas. Preliminary cost calculations show that a single-stage membrane process is economically unfavorable, primarily because of the low concentration of CO₂ (≈14 percent) in the flue gas stream. A two-stage process is more economical, but requires plant operation with a CO₂-enriched recycle stream.

technology maturity:

Bench-Scale, Using Simulated and Actual Flue Gas

project focus:

Inorganic/Polymer Composite Membrane

participant:

Ohio State University

project number:

FE0007632

NETL project manager:

José Figueroa
jose.figueroa@netl.doe.gov

principal investigator:

Dr. Winston Ho
Ohio State University
ho.192@osu.edu

partners:

**Gradient Technologies,
Trisep Corporation,
American Electric Power (AEP)**

performance period:

10/1/11 – 12/31/15

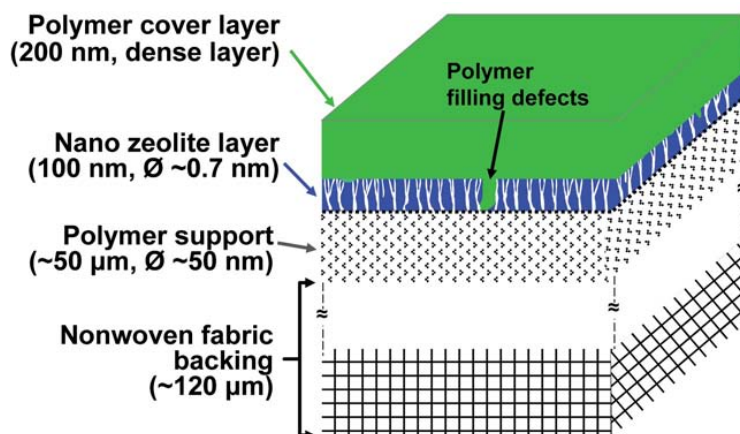

Figure 1: Supported Hybrid Membrane Concept

An important cost driver in current carbon capture membrane technologies is the energy requirement for maintaining the driving force for the membrane separation. The flue gas must be kept at atmospheric pressure and the concentrated CO₂ stream kept under vacuum (approximately 3 pounds per square inch [psi]) conditions. Preliminary calculations show that the carbon capture energy requirement can be sufficiently reduced in a two-stage process. In the first stage, CO₂ is removed from flue gas by evacuation; in the second stage, remaining CO₂ is removed using an air sweep such that the 90 percent capture target is met.

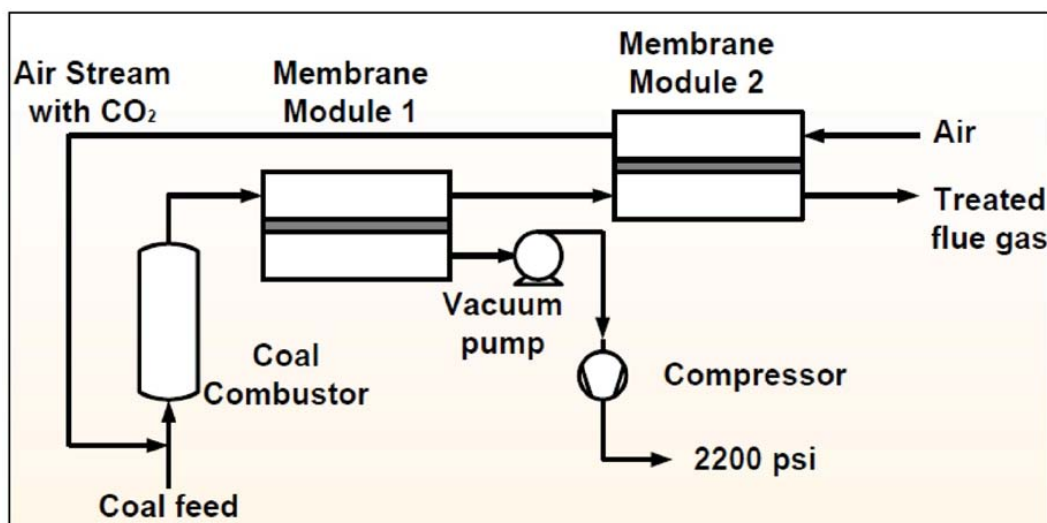

Figure 2: Process Concept for Two-Stage Membrane System

The entrance air sweep flow is the same as the air used in the current plant; the CO₂-enriched stream is used for combustion. The 95 percent pure CO₂, captured in the first stage, is then compressed to 15 MPa (\approx 2,200 psi). The U.S. Department of Energy cost targets can be met with a membrane that has a selectivity \approx 150, a permeance of 1,000 GPU, and full stability against flue gas contaminants. This combination cannot be achieved with fully polymeric membranes. Fully inorganic, micro-porous membranes are sufficiently selective and stable, but generally too expensive due to high manufacturing costs. A design that combines favorable inorganic membrane selectivity with the cost-effectiveness of polymer processing in continuous mode is the focus of this project. The micro-porous membranes are aluminosilicates. Fully inorganic structures have CO₂/N₂ selectivities of $>$ 200, and permeances of $<$ 300 GPU. The latter can be improved by reducing membrane thickness, in combination with defect abatement with a thin polydimethylsiloxane (PDMS) layer. In the membrane compositions, zeolite Y layers can be grown from solutions at 95 °C. Zeolite Y exhibits better properties but requires long growth time, which needs to be reduced to minutes. Indications are good that the growth time can be shortened significantly and that the membrane system can be deposited on available polyethersulfone or polysulfone supports.

TABLE 1: PROCESS PARAMETERS

	Units	Current R&D Value	Target R&D Value
Materials Properties			
Materials of Fabrication for Selective Layer	—	Zeolites and/or amine-containing polymer	
Materials of Fabrication for Support Layer	—	polyethersulfone or polysulfone on non-woven fabric	
Nominal Thickness of Selective Layer	nm	150–250	150–250
Membrane Geometry	—	flat sheet	spiral-wound sheet
Max Trans-Membrane Pressure	bar	can be 0.2 – 50	0.2–1.5
Hours Tested Without Significant Degradation	—	200 hours	200 hours
Manufacturing Cost for Membrane Material	\$/m ²	20	20
Membrane Performance			
Temperature	°C	57 and 102 °C	57 °C
CO ₂ Pressure Normalized Flux	GPU or equivalent	1,100 GPU	>2,500 GPU
CO ₂ /H ₂ O Selectivity	—	not yet determined	not yet determined
CO ₂ /N ₂ Selectivity	—	$\alpha = 140 - 800$ for 20 CO ₂ /80 N ₂ with $p_{\text{tot}} = 101$ kPa	$\alpha > 100$ for flue gas conditions
CO ₂ /SO ₂ Selectivity	—	not yet determined	not yet determined
Type of Measurement	—	mixed gas	mixed gas
Proposed Module Design		<i>(for equipment developers)</i>	
Flow Arrangement	—	countercurrent	
Packing Density	m ² /m ³	about 650	
Shell-Side Fluid	—	air sweep	
Flue Gas Flowrate	kg/hr	about 0.2	
CO ₂ Recovery, Purity, and Pressure	%/%/bar	>90%, >95%, 0.2–1.2 bar	
Pressure Drops Shell/Tube Side	bar	about 0.05/0.05	

Definitions:

Membrane Geometry – Flat discs or sheets, hollow fibers, tubes, etc.

Pressure Normalized Flux – For materials that display a linear dependence of flux on partial pressure differential, this is equivalent to the membrane's permeance.

GPU – Gas Permeation Unit, which is equivalent to 10⁻⁶ cm³ (1 atm, 0 °C)/cm²/s/cm Hg. For non-linear materials, the dimensional units reported should be based on flux measured in cm³ (1 atm, 0 °C)/cm²/s with pressures measured in cm Hg.

Note: 1 GPU = 3.3464 × 10⁻⁶ kg mol/m²-s-kPa [SI units].

Type of Measurement – Mixed gas measurements; target permeance and selectivities should be for mixture of gases found in desulfurized flue gas.

Flow Arrangement – Typical gas-separation module designs include spiral-wound sheets, hollow-fiber bundles, shell-and-tube, and plate-and-frame, which result in either cocurrent, countercurrent, crossflow arrangements, or some complex combination of these.

Packing Density – Ratio of the active surface area of the membrane to the volume of the module.

Shell-Side Fluid – Either the permeate (CO₂-rich) or retentate (flue gas) stream.

Other Parameter Descriptions:

Membrane Permeation Mechanism – Surface adsorption and diffusion and molecular sieving for the zeolite selective layer; solution-diffusion for the polymer cover layer.

Contaminant Resistance – Fully resistant polymer and inorganic materials.

Flue Gas Pretreatment Requirements – Removal of particulates, possibly dehydration.

Membrane Replacement Requirements – Estimated approximately 4 years.

Waste Streams Generated – N₂ with H₂O, about 1 percent CO₂ and minor impurities.

technology advantages

High CO₂/N₂ selectivity and cost-effective separation principle.

R&D challenges

Synthesis and scale-up of sufficiently selective and permeable membranes.

results to date/accomplishments

- Membrane synthesis:
 - Zeolite/polymer composite membranes showed a CO₂ permeance of 1,100 GPU and a CO₂/N₂ selectivity of >200.
 - Achieved deposition of zeolite Y on polyethersulfone support.
 - Significant membrane synthesis improvements were made, including: (1) discovery of rapid zeolite synthesis (<1 hour) for continuous membrane fabrication, (2) inorganic/organic spiral-wound membrane element, (3) synthesis of the selective layer consisting of an amine-containing polymer cover layer on top of a zeolite nanoparticle layer, and (4) zeolite membrane processing also improved.
 - The membrane process without cryogenic distillation was selected for development.
 - Growth of thin, selective zeolite Y layers achieved.
 - Optimization/improvement of zeolite and polymer layer depositions underway.
 - Continuous membrane fabrication machine operational.
 - Zeolite membrane growth time of approximately 1 hour+ achieved.
 - Element/module size of 1.8” diameter x 14” achieved.
- Membrane characterization analyses:
 - Conducted electron microscopy of 2-D focused ion beam (FIB) cross-sections.
 - Tested membrane transport using the mixed gas simulating flue gas CO₂, N₂, and H₂O concentrations.
 - Obtained X-ray diffraction (XRD) patterns indicative of zeolite formation.
 - Characterized zeolite nanoparticles by dynamic light scattering (DLS) and transmission electron microscopy (TEM) for particle size.
 - Characterized zeolites by nuclear magnetic resonance spectroscopy (NMR) for silicon (Si)/aluminum (Al) ratio.
 - Characterizing transport properties of lab and scale-up membranes using the mixed gas simulating flue gas CO₂, N₂, and H₂O concentrations.
 - Competitive H₂O/CO₂ transport studies completed for the selective layer consisting of an amine-containing polymer cover layer on top of a zeolite nanoparticle layer; the studies ongoing for the selective layer of grown zeolite membrane.
- System and cost analysis:
 - Completed the preliminary system model in Aspen and used the model to conduct preliminary techno-economic calculations.
 - Preliminary techno-economic calculations (1100 GPU and >140 selectivity) showed the potential to achieve the DOE cost target.

- Bench-scale membrane testing using real flue gas at NCCC completed.

next steps

- Membrane characterization analyses to continue.
- Refinement of system and cost analysis.
- Environmental health and safety evaluation to be completed.

available reports/technical papers/presentations

Ho, W., “Novel Inorganic/Polymer Composite Membranes for CO₂ Capture,” presented at the 2014 NETL CO₂ Capture Technology Meeting, Pittsburgh, PA, July 2014.

[http://www.netl.doe.gov/File%20Library/Events/2014/2014%20NETL%20CO₂%20Capture/W-Ho-OSU-Inorganic-Polymer-Composite-Membranes.pdf](http://www.netl.doe.gov/File%20Library/Events/2014/2014%20NETL%20CO2%20Capture/W-Ho-OSU-Inorganic-Polymer-Composite-Membranes.pdf).

Ho, W., “Novel Inorganic/Polymer Composite Membranes for CO₂ Capture,” presented at the 2013 NETL CO₂ Capture Technology Meeting, Pittsburgh, PA, July 2013. [http://www.netl.doe.gov/File%20Library/Events/2013/CO₂%20Capture/W-Ho-OSU-Inorganic-Polymer-Composite-Membranes.pdf](http://www.netl.doe.gov/File%20Library/Events/2013/CO2%20Capture/W-Ho-OSU-Inorganic-Polymer-Composite-Membranes.pdf).

Verweij, H., “Novel Inorganic/Polymer Composite Membranes for CO₂ Capture,” presented at the 2012 NETL CO₂ Capture Technology Meeting, Pittsburgh, PA, July 2012.

MEMBRANE PROCESS TO CAPTURE CARBON DIOXIDE FROM COAL-FIRED POWER PLANT FLUE GAS

primary project goals

Membrane Technology and Research, Inc. (MTR) is developing a polymeric membrane and associated process for carbon dioxide (CO₂) capture. The project includes conducting slipstream (0.05 MWe) and small pilot-scale (1 MWe) field tests using full-scale commercial membrane modules to treat combustion flue gas at the National Carbon Capture Center (NCCC).

technical goals

- Develop a thin film, composite, polymer-based membrane to increase CO₂ permeance while maintaining CO₂/nitrogen (N₂) selectivity.
- Develop a countercurrent sweep membrane module design using incoming combustion air to generate separation driving force and reduce the need for vacuum pumps and the associated parasitic energy cost.
- Fabricate commercial-scale membrane modules that meet low pressure-drop and high packing-density performance targets.
- Conduct slipstream field testing of a membrane system at NCCC; the system will process 7,000 standard m³/day (0.25 MMscfd) of flue gas (equivalent to approximately 0.05 MWe), separating about one tonne of CO₂/day.
- Further scaleup the process to conduct a 3-month small pilot-scale field test of a membrane system at a coal-fired power plant (equivalent to approximately 1 MWe, or about 20 tonne of CO₂/day).
- Analyze the performance of the membrane system, determine how it would be best integrated with a coal-fired power plant, and prepare a comparative economic analysis of the membrane-based CO₂ capture process versus other capture technologies.

technical content

MTR is developing composite membranes with high CO₂ permeance and high CO₂/N₂ selectivity for post-combustion flue gas applications. Tests indicate the membrane has 10 times the CO₂ permeance of conventional gas separation membranes. The combination of these membranes with a novel countercurrent module design that utilizes incoming combustion air to generate separation driving force greatly reduces the projected cost of CO₂ capture. MTR is developing a commercial-scale membrane module that can meet low pressure-drop and high packing-density performance targets. This thin-film membrane utilizes hydrophilic polymers and is known by the trade name “Polaris™.”

Polaris™ membranes will be used in a novel two-step membrane process design, as shown in Figure 1. The process includes two types of membrane arrangements: a conventional crossflow module and a novel countercurrent sweep module. First, the combustion flue gas enters a crossflow module, which removes most of the CO₂.

technology maturity:

Pilot-Scale, Actual Flue Gas (equivalent to 1 MW_e)

project focus:

Polymeric Membranes

participant:

Membrane Technology and Research, Inc.

project number:

FE0005795, DE-NT0005312, and FC26-07NT43085

NETL project manager:

José Figueroa
jose.figueroa@netl.doe.gov

principal investigator:

Tim Merkel
Membrane Technology and Research, Inc.
tim.merkel@mtrinc.com

partners:

Electric Power Research Institute; Southern Company/NCCC; WorleyParsons; Babcock & Wilcox, University of Illinois at Urbana-Champaign; Prairie Research Institute's Illinois Sustainable Technology Center and Illinois State Geological Affiliated Engineers, Inc.; Abbott Power Plant, and City Water, Light and Power

performance period:

4/1/07 – 9/30/15

The retentate from the crossflow module is then fed into a countercurrent sweep module, from which the permeate is recycled back to the boiler via an air sweep, which increases the CO₂ concentration of the flue gas entering the initial crossflow module. The CO₂-rich permeate from the crossflow module is then dehydrated and compressed. A second-stage crossflow module is used after compression to further enrich the CO₂ stream by recycle of the permeate back to the inlet of the compressor.

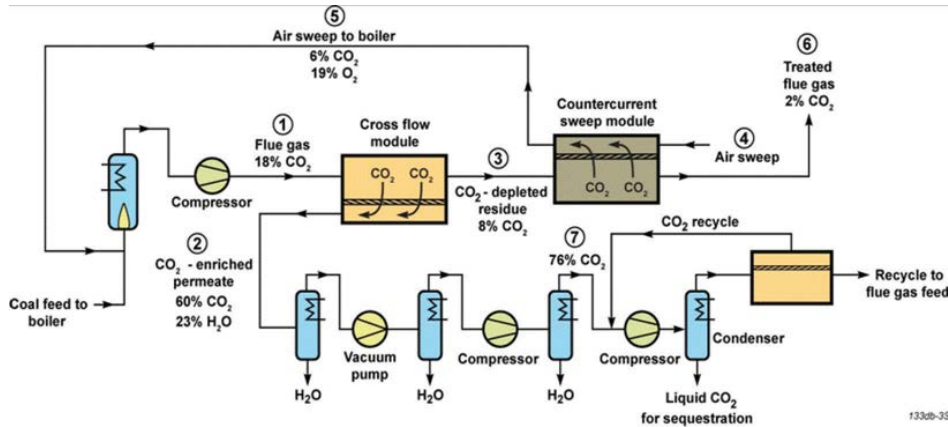

Figure 1: Process Design for the Membrane System

Polaris™ membranes will be packed into spiral-wound membrane modules, the most commonly used module design for commercial membrane installations today. Spiral-wound modules are robust, resistant to fouling, and economical; they are used in 95 percent of the reverse osmosis (RO) desalination industry and more than 60 percent of the membrane market for CO₂ removal from natural gas. Figure 2 shows the general design features of a spiral-wound membrane module. The module consists of a permeate collection tube with a spiral formation of permeate spacers and feed spacers, which allow the flue gas and separated CO₂ to flow through the device.

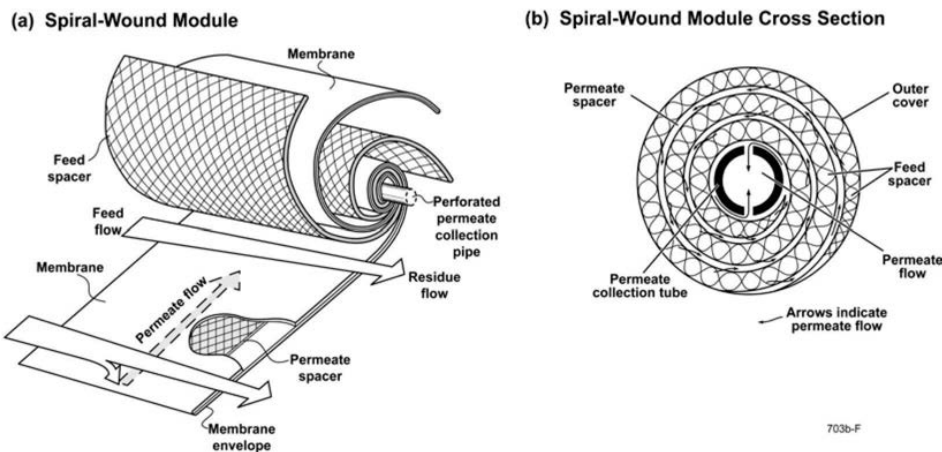

Figure 2: Schematic Diagram of a Spiral-Wound membrane module

MTR estimates that a total membrane area of about 0.5 million m² is required to achieve 90 percent CO₂ capture for a 550-MWe plant using this process design and would consume approximately 20 to 25 percent of the plant’s gross power output. Figure 3 shows a proposed design for a full-scale membrane system. Each set of modules would be stacked on a skid and connected together to form a single “mega-module.” About 130 mega-module skids would be required for a 550-MWe power plant (current RO plants already use similar numbers of modules and module skids).

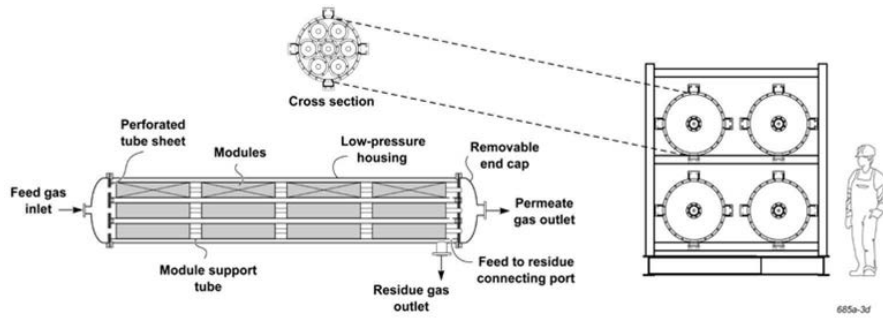

Figure 3: Proposed Design for Full-Scale Membrane System

Figure 4 shows the membrane skid used for the bench-scale slipstream test at the National Carbon Capture Center. The skid can hold up to eight (four crossflow and four countercurrent sweep), 8-inch diameter Polaris™ membrane modules. The membrane skid is designed to capture 1 tonne of CO₂ per day from a 7,000 standard m³/day (250,000 scfd) flue gas slipstream. The test is demonstrating membrane operation in commercial-scale modules and will determine typical membrane lifetimes under coal combustion flue gas operating conditions.



Figure 4: Membrane Skid Used for 1-tpd Bench-Scale Slipstream Testing at NCCC

TABLE 1: MEMBRANE PROCESS PARAMETERS

	Units	Current R&D Value	Target R&D Value
Materials Properties			
Materials of Fabrication for Selective Layer	—	proprietary polymer	
Materials of Fabrication for Support Layer	—	proprietary polymer	
Nominal Thickness of Selective Layer	μm	<1	<1
Membrane Geometry	—	spiral	spiral
Max Trans-Membrane Pressure	bar	70	70
Hours Tested Without Significant Degradation	—	8,000 (coal)	25,000 (coal)
Manufacturing Cost for Membrane Material	\$/m ²	50	10
Membrane Performance			
Temperature	°C	30	30
CO ₂ Pressure Normalized Flux	GPU or equivalent	1,700	>2,500
CO ₂ /H ₂ O Selectivity	—	0.3	0.3
CO ₂ /N ₂ Selectivity	—	25	25
CO ₂ /SO ₂ Selectivity	—	0.5	0.5
Type of Measurement	—	Mixed gas	Mixed gas
Proposed Module Design		<i>(for equipment developers)</i>	
Flow Arrangement	—	crossflow and countercurrent	
Packing Density	m ² /m ³	1,000	
Shell-Side Fluid	—	N/A	
Flue Gas Flowrate	kg/hr	500	
CO ₂ Recovery, Purity, and Pressure	%/%/bar	90%, >96%, 140 bar	
Pressure Drops Shell/Tube Side	bar	feed: <0.05 / sweep: 0.1	

Definitions:

Membrane Geometry – Flat discs or sheets, hollow fibers, tubes, etc.

Pressure Normalized Flux – For materials that display a linear dependence of flux on partial pressure differential, this is equivalent to the membrane's permeance.

GPU – Gas Permeation Unit, which is equivalent to 10⁻⁶ cm³ (1 atm, 0 °C)/cm²/s/cm Hg. For non-linear materials, the dimensional units reported should be based on flux measured in cm³ (1 atm, 0 °C)/cm²/s with pressures measured in cm Hg.

Note: 1 GPU = 3.3464 × 10⁻⁶ kg mol/m²-s-kPa [SI units].

Type of Measurement – Either mixed or pure gas measurements; target permeance and selectivities should be for mixture of gases found in de-sulfurized flue gas.

Flow Arrangement – Typical gas-separation module designs include spiral-wound sheets, hollow-fiber bundles, shell-and-tube, and plate-and-frame, which result in either cocurrent, countercurrent, crossflow arrangements, or some complex combination of these.

Packing Density – Ratio of the active surface area of the membrane to the volume of the module.

Shell-Side Fluid – Either the permeate (CO₂-rich) or retentate (flue gas) stream.

Other Parameter Descriptions:

Membrane Permeation Mechanism – Permeation through the Polaris™ membrane occurs by the passive solution-diffusion mechanism.

Contaminant Resistance – The membranes are known to be unaffected by water (H₂O), oxygen (O₂), and sulfur dioxide (SO₂). The effect of trace contaminants, such as mercury, arsenic, etc., is unknown and is being examined in the ongoing field demonstration at NCCC.

Flue Gas Pretreatment Requirements – Currently, pretreatment requirements are unknown. The current demonstration tests at NCCC treat post-flue gas desulfurization (FGD) flue gas and will help determine the need for gas treatment prior to entering the membrane system. The greatest concern of species present in flue gas is that particulate matter will foul the membranes, reducing module lifetimes. So far in extended testing at NCCC (>8000 hours), fouling has not been a significant issue.

Membrane Replacement Requirements – Membrane lifetime is being studied in ongoing demonstration tests at NCCC. The target membrane module lifetime is 3 years, which is at the conservative end of the typical industrial gas separation module lifetime of 3–5 years.

Waste Streams Generated – The membrane process will recover >95 percent of the H₂O in flue gas as liquid. The quality of this H₂O and its potential to be reused in the plant will be studied in future work.

technology advantages

- The membranes developed are 10 times more permeable to CO₂ than conventional membranes, which reduce the required membrane area and capital costs.
- A membrane system does not contain any chemical reactions or moving parts, making it simple to operate and maintain.
- The membrane material has a high tolerance to wet acid gases and is inert to O₂.
- The membrane system has a compact footprint and low energy cost.
- The membrane capture system can recover water from flue gas.
- The use of an existing air stream to generate a CO₂ partial-pressure gradient in the countercurrent sweep membrane stage reduces the need for compressors or vacuum pumps, thus reducing the overall energy cost.
- The recycled CO₂ from the air sweep to the boiler increases the CO₂ partial-pressure driving force for separation in the initial crossflow membrane stage, reducing the required membrane area and total system cost.

R&D challenges

- The membrane process requires a large membrane surface area to achieve separation due to the low partial pressure of CO₂ in flue gas.
- The countercurrent sweep module design could result in several potential inefficiencies, including: sweep-side pressure drop, concentration polarization, poor utilization of the membrane area due to module geometry, and non-countercurrent flow patterns.
- Particulate matter needs to be controlled to reduce its potential impact on the membrane lifetime.
- Feed and permeate side pressure drops may lead to excessive energy losses.
- Cost reductions for the membrane module materials will be needed if the technology is to become economically viable.
- The membrane process depends on large rotating equipment (vacuum pumps, booster fans). The availability of cost-effective equipment that can operate on full-scale flue gas streams has yet to be demonstrated.
- Scaleup and integration issues are a possibility given the large number of membranes needed to service a 550-MWe plant.

results to date/accomplishments

- Scaled-up and produced high permeance membrane formulations on commercial casting and coating equipment. Produced more than 4,000 m² of Polaris™ membrane material used to construct 203-mm (8-inch) diameter, commercial-sized, conventional crossflow and novel countercurrent sweep modules.
- Field tested pilot- and commercial-scale membrane modules with various industrial gas streams (raw coal-fired flue gas, raw natural gas-fired flue gas, and synthesis gas [syngas] containing sulfur species) for up to three months of continuous operation. The modules showed stable performance throughout these tests.
- Field tests revealed the membrane permeance is 10 times higher than existing materials and the membranes possess good stability in acid gases.
- Provided a membrane system to APS to process 4,250 m³/day (0.15 MMscfd) of natural-gas fired flue gas to provide concentrated CO₂ for testing at an experimental algae farm.
- A three-month field test of a small slipstream membrane system at the Cholla Unit 3 power plant was conducted. The membrane test skid can process 7,000 m³/day (0.25 MMscfd) of coal-fired flue gas and capture one tonne CO₂/day. The test skid is composed of four, 8-inch diameter Polaris™ membrane modules that demonstrate the crossflow and sweep configurations. The membrane modules showed stable performance for 45 days during the field testing, consistent with laboratory test results. There was minimal membrane fouling by particulates in the gas stream, which was originally anticipated to be a concern.
- MTR developed new, sweep-side flow channel configurations for the membrane sweep modules. Bench-scale testing indicated the new designs lower the sweep-side pressure drop, while maintaining the sweep performance efficiency.
- B&W conducted computational fluid dynamic (CFD) computer modeling and testing with their pilot boiler to examine the effect of CO₂ recycle to the boiler. These studies demonstrated that secondary air laden with CO₂ appears feasible as a retrofit.
- MTR's 1-TPD bench-scale system was installed at NCCC and continuous operation was initiated using first-generation Polaris™ modules. These modules have accumulated over 8000 hours of stable operation on coal flue gas. Recently, improved performance of second-generation Polaris modules was validated on this system.
- MTR's 20-TPD, 1 MWe membrane pilot commissioning was completed. Field testing of the unit is underway with over 400 hours of stable operation so far.

next steps

- Continue to operate the 1-TPD bench-scale membrane system at NCCC to accumulate additional membrane lifetime information.
- Continue operation of the 20-TPD pilot unit during the next campaign at NCCC to validate performance of low-pressure drop plate-and-frame sweep modules.
- Analyze the performance of the membrane system, determine how it would be best integrated with a coal-fired power plant, and prepare a comparative economic analysis of the membrane-based CO₂ capture process versus other capture technologies.
- Lower the membrane module cost by incorporating low-cost components with a target of \$50/m².
- Prepare for integrated operation of the small pilot membrane unit at B&W to demonstrate the full membrane capture process including recycle of CO₂ to the boiler.

available reports/technical papers/presentations

Merkel, T., et al. "Pilot Test of an Efficient Membrane Process for Post-Combustion CO₂ Capture Process," presented at the 2014 NETL CO₂ Capture Technology Meeting, Pittsburgh, PA, July 2014.

[http://www.netl.doe.gov/File%20Library/Events/2014/2014%20NETL%20CO₂%20Capture/T-Merkel-MTR-Pilot-Testing-of-a-Membrane-System.pdf](http://www.netl.doe.gov/File%20Library/Events/2014/2014%20NETL%20CO2%20Capture/T-Merkel-MTR-Pilot-Testing-of-a-Membrane-System.pdf).

Merkel, T., et al. "Pilot Test of an Efficient Membrane Process for Post-Combustion CO₂ Capture Process, Project Status Meeting, Pittsburgh, PA, April 2014. <http://www.netl.doe.gov/File%20Library/Research/Coal/carbon%20capture/post-combustion/MTR-5795-DOE-review-April-2014-non-confidential.pdf>.

Merkel, T., et al. "Pilot Test of an Efficient Membrane Process for Post-Combustion CO₂ Capture Process," presented at the 2013 NETL CO₂ Capture Technology Meeting, Pittsburgh, PA, July 2013.

[http://www.netl.doe.gov/File%20Library/Events/2013/CO₂%20Capture/T-Merkel-MTR-Slipstream-Testing-of-Membrane-CO₂-Capture-Proc.pdf](http://www.netl.doe.gov/File%20Library/Events/2013/CO2%20Capture/T-Merkel-MTR-Slipstream-Testing-of-Membrane-CO2-Capture-Proc.pdf).

Amo, K., et al. "Slipstream Testing of a Membrane CO₂ Capture Process," presented at the 2012 NETL CO₂ Capture Technology Meeting, Pittsburgh, PA, July 2012.

Merkel, T., et al. "Pilot Test of an Efficient Membrane Process for Post-Combustion CO₂ Capture Process," presented at the 2011 NETL CO₂ Capture Technology Meeting, Pittsburgh, PA, August 2011.

Amo, K. et al. "Membrane Process to Capture CO₂ from Coal-Fired Power Plant Flue Gas," presented at the 2010 NETL CO₂ Capture Technology Meeting, Pittsburgh, PA, September 2010.

Merkel, T., et al. "Power Plant Post-Combustion Carbon Dioxide Capture: An Opportunity for Membranes," *Journal of Membrane Science*, Volume 359, Issues 1-2, 1 September 2010, pages 126-139.

Merkel, T., et al. "Opportunities for Membranes in Power Generation Processes," Gordon Research Conference Presentation, July 27, 2010.

Merkel, T., et al. "A Membrane Process to Capture CO₂ from Coal-Fired Power Plant Flue Gas," presented at the Annual NETL CO₂ Capture Technology for Existing Plants R&D Meeting, Pittsburgh, PA, March 2009.

"The Membrane Solution to Global Warming," 6th Annual Conference on Carbon Capture and Sequestration, Pittsburgh, PA, May 2007.

ELECTROCHEMICAL MEMBRANE FOR CARBON DIOXIDE CAPTURE AND POWER GENERATION

primary project goals

FuelCell Energy, Inc. (FCE) is developing an electrochemical membrane (ECM)-based Combined Electric Power and Carbon dioxide Separation (CEPACS) system for carbon dioxide (CO₂) capture that also provides additional electrical power generation. The project includes bench-scale testing of a 12 m²-area ECM (molten carbonate fuel cell) system for CO₂ capture, purification, and compression.

technical goals

- Perform contaminant effect testing to establish maximum permissible concentrations of impurities in flue gas without causing unacceptable degradation of the ECM.
- Perform bench-scale membrane tests using clean, simulated flue gas.
- Complete design of balance-of-plant (BOP) components, including flue gas pretreatment subsystem.

technical content

FCE, in collaboration with Pacific Northwest National Laboratory (PNNL) and URS Corporation, is developing a novel CEPACS system. The CEPACS system is based on FCE's ECM technology derived from their internal reforming carbonate fuel cell products carrying the trade name of Direct FuelCell® (DFC®). The prominent feature of the ECM is its capability to produce electric power while capturing CO₂ from the flue gas of a pulverized coal (PC) power plant, resulting in a net efficiency gain. The ECM does not require flue gas compression as it operates on the principle of electrochemistry. The membrane utilizes a supplemental fuel (such as coal-derived synthesis gas [syngas], natural gas, or a renewable resource) as the driver for the combined CO₂ capture and electric power generation. The ECM consists of ceramic-based layers filled with carbonate salts that separate CO₂ from the flue gas. Because of the electrode's fast reaction rates, the membrane does not require a high CO₂ concentration in its feed gas. Advancement of the ECM technology will be achieved by a combination of small-scale component fabrication and testing, contaminant pretreatment evaluation, and bench-scale testing of a 12-m² ECM separation unit with CO₂ compression and chilling.

technology maturity:

Bench-Scale, Simulated Flue Gas

project focus:

Electrochemical Membrane

participant:

FuelCell Energy, Inc.

project number:

FE0007634

NETL project manager:

José Figueroa
jose.figueroa@netl.doe.gov

principal investigator:

Hossein Ghezal-Ayagh
hghezal@fce.com

partners:

**URS Corporation,
Pacific Northwest
National Laboratory**

performance period:

10/1/11 – 8/31/15

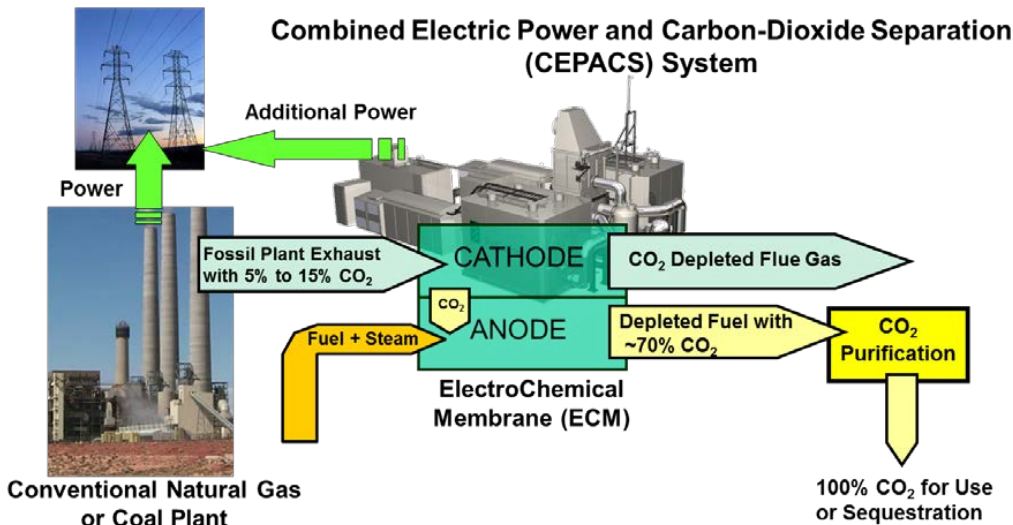

Figure 1: CEPACS System

TABLE 1: PROCESS PARAMETERS

	Units	Current R&D Value	Target R&D Value
Materials Properties			
Materials of Fabrication for Selective Layer	—	alkali carbonate/LiAlO ₂	
Materials of Fabrication for Support Layer	—	stainless steel	
Nominal Thickness of Selective Layer	μm	600	600
Membrane Geometry	—	Planar (flat sheets)	Planar (flat sheets)
Max Trans-Membrane Pressure	bar	<0.1	<0.1
Hours Tested Without Significant Degradation	—	6,500	8,000
Manufacturing Cost for Membrane Material	\$/m ²	100	100
Membrane Performance			
Temperature	°C	650	650
Volumetric Flux*	GPU or equivalent	0.016 cc/s/cm ²	>0.01 cc/s/cm ²
CO ₂ /H ₂ O Selectivity	—	infinity	infinity
CO ₂ /N ₂ Selectivity	—	infinity	infinity
CO ₂ /SO ₂ Selectivity	—	59.9 x 10 ⁶	59.9 x 10 ⁶
Type of Measurement	—	mixed	mixed
Proposed Module Design			
<i>(for equipment developers)</i>			
Flow Arrangement	—	crossflow	
Packing Density	m ² /m ³	16	
Shell-Side Fluid	—	CO ₂ -containing flue gas (permeate stream)	
Flue Gas Flowrate	kg/hr	4,640	
CO ₂ Recovery, Purity, and Pressure	%/%/bar	90%, 99.7%, 1 bar	
Pressure Drops Shell/Tube Side	bar	0.025/.01	

Definitions:

Membrane Geometry – Flat discs or sheets, hollow fibers, tubes, etc.

* Volumetric flux, rather than permeance, is considered a major performance parameter for the ECM. Permeance generally applies to membranes that use pressure or partial pressure as the driving force. In the case of ECM, the driving force is the electrochemical potential.

Type of Measurement – Either mixed or pure gas measurements; target permeance and selectivities should be for mixture of gases found in de-sulfurized flue gas.

Flow Arrangement – Typical gas-separation module designs include spiral-wound sheets, hollow-fiber bundles, shell-and-tube, and plate-and-frame, which result in either cocurrent, countercurrent, crossflow arrangements, or some complex combination of these.

Packing Density – Ratio of the active surface area of the membrane to the volume of the module.

Shell-Side Fluid – Either the permeate (CO₂-rich) or retentate (flue gas) stream.

Other Parameter Descriptions:

Membrane Permeation Mechanism – The operating principle of ECM is shown in Figure 2, along with the electrochemical reactions involved. The ECM is composed of a thin matrix layer of ceramic material (lithium aluminate), sandwiched between two electrodes (anode and cathode). The membrane is impregnated with a mixture of alkali metal (Li/Na/K) carbonate electrolyte, which constitutes a molten phase immobilized in the ECM pores at the operating temperature of 550–650 °C. The anode and cathode are porous to allow gas diffusion. The inner matrix layer is completely filled with electrolyte and is impervious to gas transport while providing a path for ionic transfer across the membrane. Carbon dioxide and oxygen present in the flue gas of a coal power plant are used as reactants at the cathode. The ECM utilizes hydrogen (H₂) at the anode. The hydrogen is made available to the anode by a mixture of a fuel (such as natural gas, syngas, or biogas) and steam. The hydrocarbon content of the fuel is internally steam reformed to produce hydrogen in the anode chamber.

The electrochemical reactions (Figure 2) involve the formation of carbonate ions (CO₃²⁻) at the cathode by the combination of O₂, CO₂, and two electrons; transport of the carbonate ions to the anode through electrolyte; and finally, reaction of the carbonate ion with H₂ at the anode, producing H₂O, CO₂, and two electrons. The internal transport of carbonate ions in an ECM assembly (or cell) and the flow of electrons in the external circuit results in electric power generation as a consequence of the electrochemical CO₂ separation process. DC power produced is converted to AC power using an inverter.

Overall, the operating mechanism of the ECM cell results in the separation (from flue gas) and transfer of CO₂ into the anode exhaust stream, which has a much reduced volumetric flow rate (resulting in a CO₂-rich stream) compared to the original flue gas stream.

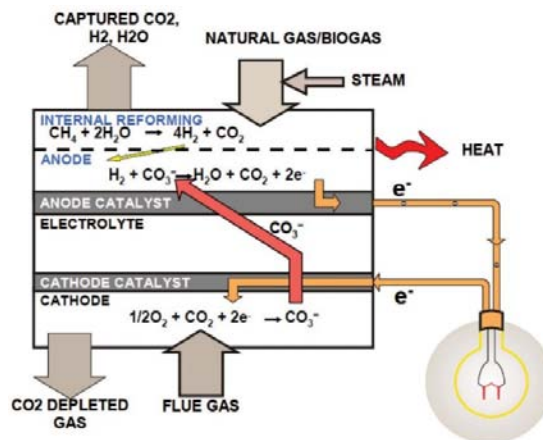

Figure 2: Separation of CO₂ in the Electrochemical Membrane Cell

Contaminant Resistance –A comprehensive contaminant evaluation study was performed to address possible interactions of the impurities that may be present in flue gas with ECM cell. Pacific Northwest National Laboratory performed the analysis and testing using ECM cells provided by FCE. Four main flue gas impurities were considered – sulfur, chlorine, mercury and selenium. The study included thermochemical modeling to predict the possible impurity-membrane interactions, and experimental work to assess the extent of the interactions, if any. Prevalent forms of S, Cl, Hg, and Se which can be present in flue gas were identified and included in the evaluation tests. Effect of these contaminants on ECM cell performance and endurance was studied. Based on the experimental results, contaminant tolerance levels for the ECM were identified. The contaminant levels expected from the flue gas clean-up (polishing FGD) subsystem were estimated by URS and compared with the ECM tolerance levels. The contaminant (effect) evaluation showed that the ECM tolerance levels are well above the contaminant levels expected in the treated flue gas. Also, the testing showed that CO₂ flux (carbon capture rate) remained constant during the tests. Testing also demonstrated that while power output decreased during operation with a higher than upper limit of sulfur tolerance, it was reversible and did not impact CO₂ flux. Laboratory tests have indicated that ECM has the potential for control of 60–70 percent of the NO_x species present in the flue gas of a coal power plant.

Flue Gas Pretreatment Requirements – Flue gas entering the CEPACS plant is first routed through a polishing wet limestone flue gas desulfurization (FGD) system to further remove SO_x contaminants. The cleaned flue gas is then mixed with supplemental air. This serves to raise the oxygen partial pressure in the stream for proper operation of ECM modules. The mixed stream is preheated to the ECM operating temperature of ~650 °C using waste heat available in the system.

Membrane Replacement Requirements – The CEPACS is designed with the ECM modules replacement after 10 years of operation. Therefore, ECM modules are required to be replaced twice during the 30-year lifetime of the CEPACS plant.

Waste Streams Generated – The CEPACS plant produces minimal waste streams. Since water is generated by the electrochemical reactions within the ECM module, the system generates excess clean process water. This excess process water can be utilized in the existing PC plant to reduce raw water consumption. The polishing FGD generates a waste stream that is treated in the existing PC plant dewatering and water treatment equipment.

technology advantages

- Unlike other scrubber and membrane-based CO₂ capture technologies, the ECM-based CEPACS system produces additional electric power, rather than reducing the net power plant output, using a supplemental fuel.
- The net efficiency of a CEPACS-equipped PC plant with >90 percent CO₂ capture is estimated to be ~6 percent higher than the net efficiency of a baseline PC plant without CO₂ capture.
- The ECM technology is anticipated to reduce flue gas NO_x emissions by 60–70 percent.
- The ECM is a modular technology, allowing for phased addition of CO₂ capture capacity over time.
- The ECM-based CEPACS system has the potential to significantly reduce the cost of CO₂ capture.
- The CEPACS system generates excess clean water as part of the electrochemical separation process.

R&D challenges

- The CEPACS process design needs to be demonstrated at large scale.
- Membrane operational characteristics need to be investigated with consideration for minimization of the system cost.

results to date/accomplishments

- A preliminary technical and economic feasibility study (PT&EFS) was completed for a CEPACS system to separate 90 percent of CO₂ from the flue gas of a reference plant (550 MW PC).
 - The reference plant equipped with CEPACS has the potential for achieving the U.S. Department of Energy incremental cost of electricity target of 35 percent. It has the lowest total overnight cost (TOC of \$2,218/kW in 2007 USD) and the highest overall efficiency (39.8 percent HHV) among the alternative systems studied.
 - The reference plant equipped with CEPACS has low cooling water consumption per unit of electricity produced. It reduces the process water consumption of the reference plant due to water-producing capabilities of the ECM operating inherently as a fuel cell.

- The reference plant equipped with CEPACS has a cost of CO₂ captured of approximately \$38/tonne of CO₂ (2011 USD), which is the lowest among the alternatives studied.
- Large-area ECM laboratory tests were conducted that verified a high CO₂ flux (>120 cc/m²/s) while separating >90 percent of CO₂ from simulated PC or NGCC plant flue gas; Also demonstrated 70–80 percent of NO_x control, with stability of CO₂ flux as the membrane ages.
- Contaminants tests indicated that the ECM is stable in the presence of S, Se, Cl, and Hg levels expected from a conventional wet-FGD polisher.
- The technology gap analysis indicated that available commercial equipment can be used in CEPACS system with no R&D needed for BOP.
- Constructed a 12-m² membrane module bench-scale test facility to evaluate ECM performance using simulated flue gas.
- Bench-scale testing of ECM system is in progress with over 6,500 hours of testing completed so far.

next steps

The bench-scale electrochemical membrane stack continues to run with the stack power and carbon capture flux at >90 percent CO₂ capture.

available reports/technical papers/presentations

M. Spinelli, S. Campanari, M.C. Romano, S. Consonni, T. G. Kreutz, H. Ghezel-Ayagh, S. Jolly, M. Di Nitto, “Molten Carbonate Fuel Cells as Means for Post-Combustion CO₂ Capture: Retrofitting Coal-Fired Steam Plants and Natural Gas-Fired Combined Cycles,” Proceedings of the ASME 2015 Power and Energy Conversion Conference, Paper 2015-49454, June 28–July 2, 2015, San Diego, CA.

S. Jolly, H. Ghezel-Ayagh, C. Willman, D. Patel, M. DiNitto, O. A. Marina, L. R. Pederson, W.A. Steen,” Novel Application of Carbonate Fuel Cell for Capturing Carbon Dioxide from Flue Gas Steams,” presented at Fuel Cell Seminar and Energy Exposition, November 10–13, 2014, Los Angeles, CA.

H. Ghezel-Ayagh, “Electrochemical Membrane for CO₂ Capture and Power Generation,” NETL-DOE 2014 Transformational Carbon Capture Technology Workshop, Arlington, VA, September 2014.

<http://www.netl.doe.gov/File%20Library/Research/Coal/carbon%20capture/post-combustion/FCE-Transformational-CarbonCapture-Technology-Workshop-Se.pdf>.

H. Ghezel-Ayagh, S. Jolly, M. DiNitto, J. Hunt, D. Patel, W. A. Steen, C.F. Richardson, O. A. Marina, and L.R. Pederson, “Progress Towards Commercialization of Electrochemical Membrane Technology for CO₂ Capture and Power Generation”, Electrochemical Society (ECS) Transactions, 2014, Volume 56, Issue 1, pp. 29-36.

H. Ghezel-Ayagh, “Electrochemical Membrane for CO₂ Capture and Power Generation No. DE-FE0007634 FuelCell Energy, Inc.,” presented at the 2014 NETL CO₂ Capture Technology Meeting, Pittsburgh, PA, July 2014.

<http://www.netl.doe.gov/File%20Library/Events/2014/2014%20NETL%20CO2%20Capture/H-Ghezel-Ayagh-FCE-Electrochemical-Membranes.pdf>.

H. Ghezel-Ayagh, S. Jolly, M. DiNitto, D. Patel, J. Hunt, W. A. Steen, C.F. Richardson, O. A. Marina,” A Novel System for Carbon Dioxide Capture Utilizing Electrochemical Membrane Technology”, Electrochemical Society (ECS) Transactions, 2013, Volume 51, Issue 1, pp. 265-272.

H. Ghezel-Ayagh, “Electrochemical Membrane for CO₂ Capture and Power Generation No. DE-FE0007634 FuelCell Energy, Inc.,” presented at the 2013 NETL CO₂ Capture Technology Meeting, Pittsburgh, PA, July 2013.

<http://www.netl.doe.gov/File%20Library/Events/2013/CO2%20Capture/H-Ghezel-Ayagh-FCE-Electrochemical-Membranes.pdf>.

H. Ghezel-Ayagh, “Electrochemical Membrane for CO₂ Capture and Power Generation No. DE-FE0007634 FuelCell Energy, Inc.,” presented at the 2012 NETL CO₂ Capture Technology Meeting, Pittsburgh, PA, July 2012.

H. Ghezel-Ayagh, S. Jolly, D. Patel, W. A. Steen, C. F. Richardson, and O. A. Marina, “Electrochemical Membrane for Carbon Dioxide Capture and Power Generation,” presented at the 11th Annual Conference on Carbon Capture Utilization & Sequestration, Pittsburgh, PA, April 30–May 3, 2012.

J. Hunt, C. Willman, H. Ghezel-Ayagh, P. Singh, "Carbon Capture from the Industrial Sites Using a High Temperature Ionic Membrane," presented at the 11th Annual Conference on Carbon Capture Utilization & Sequestration, Pittsburgh, PA, April 30 – May 3, 2012.

H. Ghezel-Ayagh, J. Hunt, S. Jolly, D. Patel, and R. Sanderson, "Energy Sustainability through Combined Electric Power Production and Carbon-Dioxide Separation (CEPACS) Systems," ECS Transactions, Editor(s): M. Williams, Volume 42, Issue No. 1, pp. 23-29, 2011.

H. Ghezel-Ayagh, "Electrochemical Membrane for Carbon Dioxide Capture and Power Generation," International Colloquium on Environmentally Preferred Advanced Power Generation (ICEPAG) Costa Mesa, CA, February 7–9, 2012.

BENCH-SCALE, HIGH-PERFORMANCE, THIN FILM COMPOSITE HOLLOW FIBER MEMBRANE FOR POST-COMBUSTION CARBON DIOXIDE CAPTURE

primary project goals

General Electric Global Research (GE) is developing high-performance, thin film polymer composite hollow fiber membranes and advanced processes for economical post-combustion carbon dioxide (CO₂) capture. The project includes bench-scale testing to tune the properties of a novel phosphazene polymer membrane and decrease costs through development of innovative fabrication techniques.

technical goals

- Optimize phosphazene polymer and coating solution: Synthesize phosphazene polymer, optimize separation performance, and develop processable coating solutions.
- Fabricate hollow fiber support layer: Produce highly porous, robust hollow fiber supports with controlled surface porosity from commercially available materials.
- Fabricate composite coated hollow fiber membranes: Develop processes to apply thin layer coatings on hollow fiber supports and elucidate fundamental polymer properties.
- Test membranes at bench-scale under flue gas conditions: Exposure and performance test materials and membranes under flue-gas conditions.
- Conduct process evaluation and module design: Conduct technical and economical process evaluation and module design and fabrication.

technical content

GE and partners are developing a high-performance, thin film polymer composite hollow fiber membrane and advanced process for economical post-combustion CO₂ capture. The project utilizes novel phosphazene polymeric materials to produce an economical and scalable composite hollow fiber membrane module.

The membrane will be optimized at bench-scale, including tuning the properties of the phosphazene polymer in a coating solution and fabricating highly engineered porous hollow fiber supports. The project will also define the processes for coating the fiber support to manufacture thin, defect-free composite hollow fiber membranes.

technology maturity:

Bench-Scale, Simulated Flue Gas

project focus:

Composite Hollow Fiber Membranes

participant:

General Electric Global Research Center

project number:

FE0007514

NETL project manager:

Isaac Aurelio
isaac.aurelio@netl.doe.gov

principal investigator:

Paul Glaser
General Electric
paul.glaser@ge.com

partners:

Idaho National Laboratory,
Western Research Institute,
Georgia Institute of Technology

performance period:

10/1/11 – 12/31/14



Figure 1: GE Test Rig – Flat Sheet and Hollow Fiber Membranes

The physical, chemical, and mechanical stability of the materials (individual and composite) to flue gas components will be evaluated using exposure and performance tests. Membrane fouling and cleanability studies will define long-term performance.

GE and the Georgia Institute of Technology (Georgia Tech) will work together on developing processes to apply the thin layer coating formulations onto the hollow fiber supports. GE will leverage the knowledge gained from using its flat sheet film coating apparatus to enable development of the continuous dip process for coating of hollow fiber membrane supports. Georgia Tech will use the in situ process developed to coat porous cellulose acetate hollow fibers with defect-free layers as a benchmark, which will be further adapted to obtain thin, defect-free coated layers. Both the continuous dip coating and batch in situ processes will be optimized to provide economical and scalable coated composite hollow fiber membranes.



Figure 2: Georgia Tech Hollow Fiber Fabrication Line

Working with Idaho National Laboratory, Georgia Tech will characterize phosphazene material properties in films cast on porous polymer supports to elucidate polymer properties including aging, membrane fouling, and cleanability. The characterization techniques will enable a better understanding of polymer and composite membrane performance. Membrane performance validation testing under flue-gas conditions will be performed at Western Research Institute's coal combustion test facility. Module design and technical and economic feasibility analyses will be conducted to evaluate the overall performance and impact of the process on the cost of electricity.

TABLE 1: PROCESS PARAMETERS

	Units	Current R&D Value	Target R&D Value
Materials Properties			
Materials of Fabrication for Selective Layer	—	phosphazene	
Materials of Fabrication for Support Layer	—	polymer	
Nominal Thickness of Selective Layer	μm	1–10	<1
Membrane Geometry	—	flat sheet/hollow fiber	hollow fiber
Max Trans-Membrane Pressure	bar	2–5	up to 10
Hours Tested Without Significant Degradation	—	200 (flat sheet) 100 (hollow fiber)	100–1,000
Manufacturing Cost for Membrane Material	\$/m ²	—	—
Membrane Performance			
Temperature	°C	30 and 65	30 and 60
CO ₂ Pressure Normalized Flux	GPU or equivalent	50–275 Barrer (flat sheet 30 °C) 100–425 Barrer (flat sheet 65 °C) up to 70 GPU (hollow fibers 35 °C)	1,000–2,500 GPU (hollow fibers)
CO ₂ /H ₂ O Selectivity	—	8–10	8–10
CO ₂ /N ₂ Selectivity	—	15–20 (65 °C) flat sheet 30–40 (30 °C) flat sheet 10–35 (35 °C) hollow fibers	30–40
CO ₂ /SO ₂ Selectivity	—	not tested	non tested
Type of Measurement	—	mixed gas	mixed gas
Proposed Module Design		<i>(for equipment developers)</i>	
Flow Arrangement	—	countercurrent	
Packing Density	m ² /m ³	>1,000	
Shell-Side Fluid	—	retentate	
Flue Gas Flowrate	kg/hr	<1	
CO ₂ Recovery, Purity, and Pressure	%/%/bar	>90%, 60–80%, 0.2–1 bar	
Pressure Drops Shell/Tube Side	bar	1–4	

Definitions:

Membrane Geometry – Flat discs or sheets, hollow fibers, tubes, etc.

Pressure Normalized Flux – For materials that display a linear dependence of flux on partial pressure differential, this is equivalent to the membrane's permeance.

GPU – Gas Permeation Unit, which is equivalent to 10⁻⁶ cm³ (1 atm, 0 °C)/cm²/s/cm Hg. For non-linear materials, the dimensional units reported should be based on flux measured in cm³ (1 atm, 0 °C)/cm²/s with pressures measured in cmHg.

Note: 1 GPU = 3.3464 × 10⁻⁶ kg mol/m²-s-kPa [SI units].

Type of Measurement – Either mixed or pure gas measurements; target permeance and selectivities should be for mixture of gases found in de-sulfurized flue gas.

Flow Arrangement – Typical gas-separation module designs include spiral-wound sheets, hollow-fiber bundles, shell-and-tube, and plate-and-frame, which result in either cocurrent, countercurrent, crossflow arrangements, or some complex combination of these.

Packing Density – Ratio of the active surface area of the membrane to the volume of the module.

Shell-Side Fluid – Either the permeate (CO₂-rich) or retentate (flue gas) stream.

Other Parameter Descriptions:

Membrane Permeation Mechanism – Solution-diffusion mechanism.

Contaminant Resistance – Phosphazene-based membranes have been tested to be resistant to contaminant species such as oxygen (O₂), nitrogen oxide (NO_x), sulfur dioxide (SO₂), and moisture present in coal flue gas.

Flue Gas Pretreatment Requirements – Fly ash particulate removal.

Membrane Replacement Requirements – Membranes found to be stable with up to 200 hours of testing. Long-term stability tests are currently in progress.

Waste Streams Generated – Acidic water condensate stream.

technology advantages

- Surface property optimization to reduce fly ash adhesion.
- Highly scalable, low-cost hollow fiber support platform.
- Ease of cleaning should provide longer membrane life.
- Phosphazene polymer with high permeability and selectivity.

R&D challenges

- Fouling potential from fly ash/particulates.
- Permeability and selectivity at 60 °C lower than anticipated.
- Large membrane area requirements and process integration.

results to date/accomplishments

- Synthesized phosphazene polymer, characterized separations performance under realistic flue gas conditions, and developed hollow fiber support coating solutions.
- Developed engineered, high-porosity, hollow fiber supports.
- Built/upgraded bench-scale membrane coating and testing facilities.
- Completed initial process technical and economic feasibility study.
- Fabricated phosphazene coated defect-free hollow fiber membranes.
- Membrane performance studies conducted showed stability over >100 hours of testing.

next steps

- Optimize phosphazene polymer coatability on hollow fiber supports.
- Optimize the continuous dip and batch coating processes to provide economical and scalable coated composite hollow fiber membranes.
- Continue testing of coated composite hollow fiber membranes at bench scale under flue gas conditions.
- Conduct final technical and economic feasibility analyses and an environmental, health, and safety assessment.

available reports/technical papers/presentations

Bhandari, D., et al., “Composite Hollow Fiber Membranes for Post Combustion CO₂ Capture,” presented at the 2014 NETL CO₂ Capture Technology Meeting, Pittsburgh, PA, July 2014.

[http://www.netl.doe.gov/File%20Library/Events/2014/2014%20NETL%20CO₂%20Capture/D-Ajit-Bhandari-GE-Composite-Hollow-Fiber-Membranes.pdf](http://www.netl.doe.gov/File%20Library/Events/2014/2014%20NETL%20CO2%20Capture/D-Ajit-Bhandari-GE-Composite-Hollow-Fiber-Membranes.pdf).

Bhandari, D., et al., “Composite Hollow Fiber Membranes for Post Combustion CO₂ Capture,” presented at the 2013 NETL CO₂ Capture Technology Meeting, Pittsburgh, PA, July 2013.

[http://www.netl.doe.gov/File%20Library/Research/Coal/ewr/CO₂/DBhandari-GEGR-2013-CO₂-NETL-Conference.pdf](http://www.netl.doe.gov/File%20Library/Research/Coal/ewr/CO2/DBhandari-GEGR-2013-CO2-NETL-Conference.pdf).

Bhandari, D., et al., “Composite Hollow Fiber Membranes for Post Combustion CO₂ Capture,” presented at the 2013 North American Membrane Society Meeting, Boise, ID, June 2013.

[http://www.netl.doe.gov/File%20Library/Research/Coal/ewr/CO₂/GEGR-2013-CO₂-NAMS-Conference.pdf](http://www.netl.doe.gov/File%20Library/Research/Coal/ewr/CO2/GEGR-2013-CO2-NAMS-Conference.pdf).

Bhandari, D., et al., “Composite Hollow Fiber Membranes for Post Combustion CO₂ Capture,” presented at the 2012 NETL CO₂ Capture Technology Meeting, Pittsburgh, PA, July 2012.

LOW-PRESSURE MEMBRANE CONTACTORS FOR CO₂ CAPTURE

primary project goals

Membrane Technology and Research (MTR) is developing a new type of membrane contactor (or mega-module) to decrease capture costs, energy use, and system footprint through bench-scale testing of a module with a membrane area that is 100 m², 5 times larger than that of current modules used for carbon dioxide (CO₂) capture.

technical goals

- Develop a module design to reduce energy cost by lowering module pressure drop.
- Develop a module design with a large membrane area.
- Develop a module design to reduce manifold complexity, footprint, and cost.

technical content

MTR is developing a new type of membrane contactor (or mega-module) to separate CO₂ from power plant flue gas. This module membrane area is 100 m², which is 4–5 times larger than that of current modules used for CO₂ capture. The countercurrent sweep module is crucial to the MTR-developed CO₂ removal from flue gas process, as this membrane module permits the use of air as a sweep gas, which increases the CO₂ flux through the membrane without requiring additional compression energy. This means the CO₂ concentration in the flue gas is increased at a minimal energy cost.

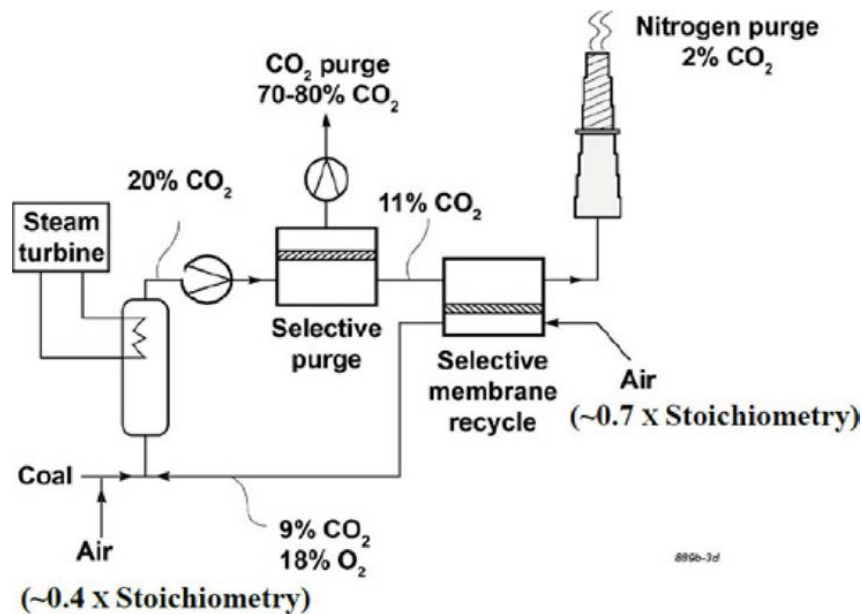

Figure 1: Two-Stage Membrane CO₂ Capture Process

technology maturity:

Bench-Scale, Simulated and Actual Flue Gas

project focus:

Low-Pressure Membrane Contactors (mega-module)

participant:

Membrane Technology and Research, Inc.

project number:

FE0007553

NETL project manager:

Morgan Mosser
morgan.mosser@netl.doe.gov

principal investigator:

Richard Baker
Membrane Technology and Research, Inc.
richard.baker@mtrinc.com

partners:

University of Toledo

performance period:

10/1/11 – 9/30/14

TABLE 1: PROCESS PARAMETERS

	Units	Current R&D Value	Target R&D Value
Materials Properties			
Materials of Fabrication for Selective Layer		proprietary polymer	
Materials of Fabrication for Support Layer		proprietary polymer	
Nominal Thickness of Selective Layer	μm	<1	<1
Membrane Geometry		plate-and-frame	plate-and-frame
Max Trans-Membrane Pressure	bar	70	70
Hours Tested Without Significant Degradation		500	500
Manufacturing Cost for Membrane Material	\$/m ²	100	10
Membrane Performance			
Temperature	°C	30	30
CO ₂ Pressure Normalized Flux	GPU or equivalent	1,500	>2,500
CO ₂ /H ₂ O Selectivity	—	0.5	0.5
CO ₂ /N ₂ Selectivity	—	50	50
CO ₂ /SO ₂ Selectivity	—	0.5	0.5
Type of Measurement	—	pure gas	pure gas
Proposed Module Design		<i>(for equipment developers)</i>	
Flow Arrangement	—	cross-flow	
Packing Density	m ² /m ³	1,000	
Shell-Side Fluid	—	N/A	
Flue Gas Flowrate	kg/hr	5,000	
CO ₂ Recovery, Purity, and Pressure	%/%/bar	90%, >96%, 140 bar	
Pressure Drops Shell/Tube Side	bar	feed: 0.1; sweep:0.2	

Definitions:

Membrane Geometry – Flat discs or sheets, hollow fibers, tubes, etc.

Pressure Normalized Flux – For materials that display a linear dependence of flux on partial pressure differential, this is equivalent to the membrane's permeance.

GPU – Gas Permeation Unit, which is equivalent to 10⁻⁶ cm³ (1 atm, 0 °C)/cm²/s/cm Hg. For non-linear materials, the dimensional units reported should be based on flux measured in cm³ (1 atm, 0 °C)/cm²/s with pressures measured in cm Hg.

Note: 1 GPU = 3.3464 × 10⁻⁶ kg mol/m²-s-kPa [SI units].

Type of Measurement – Either mixed or pure gas measurements; target permeance and selectivities should be for mixture of gases found in de-sulfurized flue gas.

Flow Arrangement – Typical gas-separation module designs include spiral-wound sheets, hollow-fiber bundles, shell-and-tube, and plate-and-frame, which result in either cocurrent, countercurrent, crossflow arrangements, or some complex combination of these.

Packing Density – Ratio of the active surface area of the membrane to the volume of the module.

Shell-Side Fluid – Either the permeate (CO₂-rich) or retentate (flue gas) stream.

Other Parameter Descriptions:

Contaminant Resistance – The membranes are known to be unaffected by water (H₂O), oxygen (O₂), and sulfur dioxide (SO₂). The effect of trace contaminants, such as mercury, arsenic, etc., is unknown and is being examined in the ongoing field demonstration at the National Carbon Capture Center (NCCC) in Wilsonville, AL, under a different U.S. Department of Energy National Energy Technology Laboratory (DOE/NETL)-sponsored project (DE-FE0005795).

Flue Gas Pretreatment Requirements – Currently, pretreatment requirements are unknown. The current demonstration tests at NCCC treat post-flue gas desulfurization (FGD) flue gas and will help determine the need for gas treatment prior to entering the membrane system. The greatest concern of species present in flue gas is that particulate matter will foul the membranes, reducing module lifetimes. Particulate filters that can achieve an order of magnitude better ash removal than a standard bag house, and are used today to treat refinery and gasification streams, may be needed.

Waste Streams Generated – The membrane process will recover >95 percent of the H₂O in flue gas as liquid. The quality of this H₂O and its potential to be reused in the plant will be studied in future work.

technology advantages

- In flue gas applications, the novel countercurrent sweep module recycles CO₂ to the boiler with an air sweep, which increases the CO₂ concentration in the flue gas with minimal energy input.
- The recycle of CO₂ to the boiler increases the concentration of CO₂ in the flue gas, which could make the CO₂ capture process easier for technologies other than membranes.
- The novel countercurrent sweep module design has low-pressured drop, which reduces the energy costs.
- Mega-modules (500 m² or larger) reduce the manifolding complexity, footprint, and cost of the membrane system.

R&D challenges

- The novel sweep plate and framed design will need to overcome several issues, including sweep-side pressure drop, poor utilization of the membrane area due to module geometry, and non-uniform flow patterns.
- Spacer design and selection needs to maximize packing density and mechanical support while minimizing pressure drop.
- Scaleup issues associated with building membrane modules 10–20 times larger than conventional modules.

results to date/accomplishments

- Completed design and fabrication of various 20-m² prototype membrane modules.
- Completed pressure drop and CO₂ separation performance testing of various 20-m² prototype membrane modules with bench-scale lab test system
- Completed design and construction of larger lab test system, sized for parametric studies of 100-m² membrane modules.
- Conducted CFD simulations of various sweep module designs that incorporate pressure drop, velocity profiles, and mass transfer.
- A large sweep module test unit was designed and assembled at MTR for all pure-gas, pressure drop, and CO₂ separation performance testing of 100 m² modules. The pressure drop through the plate-and-frame module is more than 10-fold lower than that through the best modified spiral module, significantly lower than the project target of 1.5 psi, and demonstrate substantial energy savings for the membrane capture process.
- A CFD comparative analysis of crossflow and countercurrent sweep membrane modules demonstrated that countercurrent/sweep modules require 35 percent less membrane area than crossflow modules to remove the same amount of CO₂, but the pressure drop through crossflow modules was lower.
- A 500-m² sweep membrane module skid was designed and fabricated for field testing. A pressure vessel with five 100-m² membrane modules can be run individually or as a group. The skid was designed for integration into the existing MTR 20-tpd CO₂ capture pilot test unit for testing at NCCC in Wilsonville, AL. The 500-m² sweep module skid is to be tested at NCCC in early 2015.

- A detailed performance and economic analysis of the MTR membrane CO₂ capture process with low-pressure sweep modules was performed. The methodology used by MTR to evaluate the membrane process is consistent with Case 10 of the 2010 DOE report: Econamine was used to capture 90 percent of the flue gas CO₂. The “all membrane” case demonstrates savings over the Econamine CO₂ capture process, but the cost is still higher than the DOE target of \$40/tonne CO₂ captured.

next steps

This project ended on September 30, 2014.

available reports/technical papers/presentations

Baker, R., et.al, “Low-Pressure Membrane Contactors for CO₂ Capture,” presented at the 2014 NETL CO₂ Capture Technology Meeting, Pittsburgh, PA, July 2014. <http://www.netl.doe.gov/File%20Library/Events/2014/2014%20NETL%20CO2%20Capture/R-Baker-MTR-Low-Pressure-Membrane-Contactors.pdf>.

Baker, R., et.al, “Low-Pressure Membrane Contactors for CO₂ Capture,” presented at the 2013 NETL CO₂ Capture Technology Meeting, Pittsburgh, PA, July 2013. <http://www.netl.doe.gov/File%20Library/Events/2013/CO2%20Capture/R-Baker-MTR-Low-Pressure-Membrane-Contactors.pdf>.

Baker, R., et.al, “Low-Pressure Membrane Contactors for CO₂ Capture,” presented at the 2012 NETL CO₂ Capture Technology Meeting, Pittsburgh, PA, July 2012.

CO₂ CAPTURE MEMBRANE PROCESS FOR POWER PLANT FLUE GAS

primary project goals

Research Triangle Institute (RTI) set out to develop an advanced hollow-fiber, polymeric membrane-based process that can be cost-effectively retrofitted into current pulverized coal (PC)-fired power plants to capture at least 90 percent of the carbon dioxide (CO₂) from the plant's flue gas.

technical goals

- Develop new fluorinated polymers as membrane materials that have superior CO₂ separation properties compared to conventional and competitive membrane platforms. A minimum selectivity of 30 for CO₂ over nitrogen (N₂) and CO₂ permeance in excess of 300 gas permeance unit (GPU) are targeted. Fluorinated polymers are a promising material platform because they exhibit excellent chemical stability to moisture, sulfur dioxide (SO₂), and nitrogen oxide (NO_x) contaminants present in flue gas.
- Develop next-generation polycarbonate hollow-fiber membranes and membrane modules with higher CO₂ permeance than current commercial polycarbonate membranes.
- Develop and fabricate improved membrane hollow fibers and module designs to handle large flue gas flow rates and high CO₂ permeate flow rates with minimal pressure drop.
- Identify and develop CO₂ capture membrane process design and integration strategies suitable for retrofit installation.

technical content

Project research efforts include development of membrane materials and membrane hollow fibers, membrane module design and fabrication, and process design.

RTI pursued the development of two membrane material platforms. As a near-term membrane platform solution, RTI worked with Generon to develop next-generation, high-flux polycarbonate hollow-fiber membranes and membrane modules with higher CO₂ permeance than current-generation, commercial polycarbonate membranes. Hollow-fiber membranes made from the high-flux polycarbonate have been successfully developed, scaled up, and fabricated into module separation devices. Laboratory-scale membrane modules have been studied with simulated flue gas mixtures with and without flue gas contaminants.

For a longer-term membrane platform solution, RTI worked with Arkema to develop improved CO₂ capture membrane materials based on the polymer chemistry of polyvinylidene fluoride [PVDF], the chemical structure of which is shown in Figure 1 and comprises the [CH₂-CF₂]_n repeat unit. PVDF is well suited for contact with flue gas, possessing high chemical resistance to acids and oxidants, specific affinity for CO₂ for high CO₂ solubility, and high thermal stability (T_d ≈ 340°C). PVDF also features excellent physical and mechanical properties, durability, and longevity suited to the fiber extrusion process used to fabricate mem-

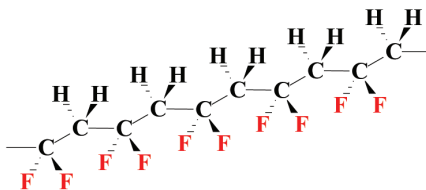

Figure 1: Chemical Structure of PVDF

technology maturity:

Bench-Scale, Using Simulated Flue Gas

project focus:

Hollow-Fiber, Polymeric Membrane

participant:

Research Triangle Institute

project number:

NT0005313

NETL project manager:

Andrew O’Palko
andrew.opalko@netl.doe.gov

principal investigator:

Lora Toy
Research Triangle Institute
ltoy@rti.org

partners:

Arkema
Generon IGS

performance period:

10/1/08 – 9/30/11

brane hollow fibers. However, conventional PVDF is a homopolymer that is semicrystalline and has CO_2/N_2 selectivity of ≈ 23 and low CO_2 permeance of ≈ 10 GPU. Arkema has pursued synthesizing and developing advanced, PVDF based copolymers possessing improved CO_2 permeance and selectivity.

In this project, the membrane under development was in the form of hollow fibers that are packaged into compact, high surface area-to-volume module devices. Multiple modules were utilized in a given CO_2 capture membrane system for power plant applications due to the large quantity of flue gas to be processed. The modularity of the membrane separation devices allows for easy adaptation to different levels of CO_2 removal desired by simply adding or subtracting the number of membrane modules used. Figure 2 shows a cross-section of a hollow-fiber membrane module. A single-membrane module consists of hundreds of thousands to more than a million micron-sized diameter hollow fibers bundled together. A couple of individual membrane hollow fibers, a small bundle loop of fibers, and modules of different sizes are shown in Figure 3. As flue gas flows through the membrane fibers, the feed is split into two streams. A permeate stream enriched in CO_2 is produced by the preferential transport of CO_2 across the fiber walls. The remaining flue gas (non-permeate) flows out of the membrane module as a CO_2 -depleted retentate stream that is sent to the plant stack for discharge to the atmosphere.

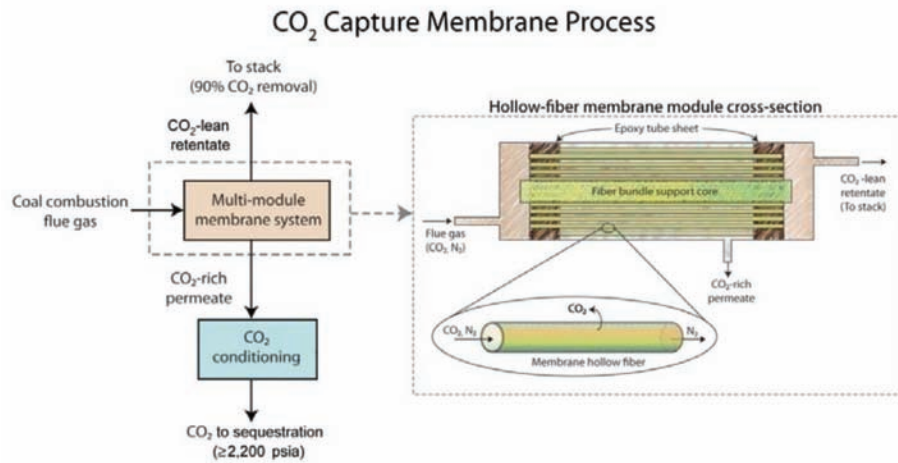

Figure 2: Cross-Section of a Hollow-Fiber Membrane Module



Individual Membrane Hollow Fibers

Small Bundle Loop of Hollow Fibers

Various Membrane Module Sizes

Figure 3: Membrane Hollow Fibers

Process simulations for a single-stage membrane process were conducted to determine the sensitivity of CO_2 removal performance and permeate CO_2 purity to different parameters, including membrane flux (permeance), membrane selectivity, membrane fiber dimensions, and membrane pressure driving force. An important outcome of this sensitivity analysis was the understanding that membrane property development should focus on improving both permeance and selectivity together rather than individually.

To achieve high levels of CO_2 capture and purity, RTI developed the three-stage membrane process shown in Figure 4, where the membrane stages are represented by M1, M2, and M3. The flue gas is compressed and fed to the first membrane stage M1. To obtain a net 90 percent removal of CO_2 from the stream ultimately sent to the stack, the CO_2 -depleted retentate exiting M1 is fed to M3, which is operated with a permeate-side air sweep to enhance removal of more CO_2 . Before being released into the stack, the pressurized M3 retentate is sent to an expander to recover the energy associated with high pressure. The resulting M3 permeate is a CO_2 enriched air stream that is sent back to the boiler. In the second membrane stage M2, the CO_2 captured in the M1

permeate is further concentrated. The resulting CO₂-rich M2 permeate is then compressed and dehydrated to produce the final, sequestration-ready CO₂ capture stream. The M2 retentate is recycled and fed back to M1. The numbers shown in Figure 4 are for a 550-MW coal-fired power plant to achieve 90 percent CO₂ capture and 95 percent CO₂ purity in the capture stream using the high-flux polycarbonate membrane (400 GPU; CO₂/N₂ = 35).

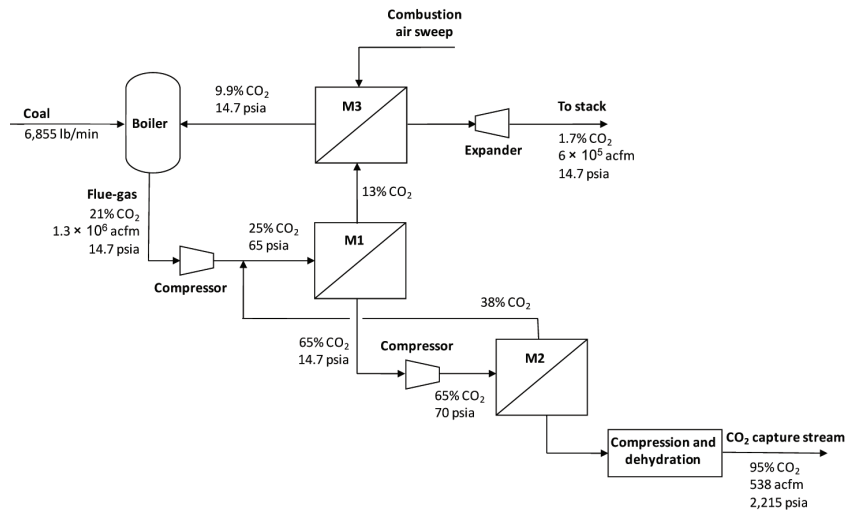

Figure 4: RTI's Three-Stage CO₂ Capture Membrane Process Design

TABLE 1: MEMBRANE PROCESS PARAMETERS

	Units	Current R&D Value	Target R&D Value
Materials Properties			
Materials of Fabrication for Selective Layer	-	Polycarbonate-based and Vinylidene fluoride-based	
Materials of Fabrication for Support Layer	-	N/A	
Nominal Thickness of Selective Layer	μm	0.05	0.05
Membrane Geometry	-	Hollow-fiber	Hollow-fiber
Max Trans-Membrane Pressure	bar	15 (Not tested higher)	15
Hours Tested Without Significant Degradation	-	165	300 (coal)
Manufacturing Cost for Membrane Material	\$/m ²	32	8
Membrane Performance			
Temperature	°C	25 – 30	50
CO ₂ Pressure Normalized Flux	GPU or equivalent	400	1,000
CO ₂ /H ₂ O Selectivity	-	0.04	0.01 – 0.02
CO ₂ /N ₂ Selectivity	-	35	50
CO ₂ /SO ₂ Selectivity	-	≈1	<0.5 or >2
Type of Measurement	-	Ideal and mixed	Ideal and mixed
Proposed Module Design			
Flow Arrangement	-	Countercurrent	
Packing Density	m ² /m ³	9,000	
Shell-Side Fluid	-	Permeate	
Flue Gas Flowrate	kg/hr	(Unknown at this stage)	
CO ₂ Recovery, Purity, and Pressure	% / % / bar	90%, 95+%, 1 bar	

TABLE 1: MEMBRANE PROCESS PARAMETERS

	Units	Current R&D Value	Target R&D Value
Pressure Drops Shell/Tube Side	bar		<0.1
Estimated Absorber/Stripper Cost of Manufacturing and Installation	$\frac{\$}{\text{kg/hr}}$		(Unknown at this stage)

Definitions:

Membrane Geometry – Flat discs or sheets, hollow fibers, tubes, etc.

Pressure Normalized Flux – For materials that display a linear dependence of flux on partial pressure differential, this is equivalent to the membrane's permeance.

GPU – Gas Permeation Unit, which is equivalent to $10^{-6} \text{ cm}^3 (1 \text{ atm}, 0^\circ\text{C})/\text{cm}^2/\text{s}/\text{cm Hg}$. For non-linear materials, the dimensional units reported should be based on flux measured in $\text{cm}^3 (1 \text{ atm}, 0^\circ\text{C})/\text{cm}^2/\text{s}$ with pressures measured in cmHg. Note: $1 \text{ GPU} = 3.3464 \times 10^{-6} \text{ kg mol/m}^2\text{-s-kPa}$ [SI units].

Type of Measurement – Either mixed or pure gas measurements; target permeance and selectivities should be for mixture of gases found in de-sulfurized flue gas.

Flow Arrangement – Typical gas-separation module designs include spiral-wound sheets, hollow-fiber bundles, shell-and-tube, and plate-and-frame, which result in either co-current, counter-current, cross-flow arrangements, or some complex combination of these.

Packing Density – Ratio of the active surface area of the membrane to the volume of the module.

Shell-Side Fluid – Either the permeate (CO_2 -rich) or retentate (flue gas) stream.

Estimated Cost – Basis is kg/hr of CO_2 in CO_2 -rich product gas; assuming targets are met.

Other Parameter Descriptions:

Membrane Permeation Mechanism – Gas permeation in the high-flux polycarbonate and PVDF-based membrane platforms occurs due to a partial pressure driving force across the membrane. The specific permeation mechanism obeyed is the solution-diffusion model for gas transport in nonporous polymers. According to this model, preferential permeation of certain gas species occurs because they are more soluble in the polymer membrane, have a higher diffusion coefficient in the polymer membrane, or both. In this project, the preferentially permeated species CO_2 has both greater diffusivity and greater solubility than N_2 in the polycarbonate- and PVDF-based membranes.

Contaminant Resistance – Membrane resistance to contaminant species (NO_x , SO_2 , moisture) found in flue gas was investigated in continuous, seven-day, bench-scale separation performance stability tests with contaminant-containing CO_2/N_2 mixtures. The permeance of the high-flux polycarbonate membrane showed some sensitivity to contaminants such as NO_x , but its selectivity was stable. The new PVDF-based membrane material platform, because of its intrinsically high-chemical resistance, exhibited excellent permeability (permeance) and selectivity stability in the contaminant tests.

Flue Gas Pretreatment Requirements – Before being fed to the membrane system, the flue gas from the plant stack must be conditioned to remove solid particulates and any condensed/entrained liquids (essentially liquid water).

Membrane Replacement Requirements – Based on seven-day, bench-scale contaminant resistance testing results, replacement cycle for high-flux polycarbonate membranes is anticipated to be roughly every five years. In the presence of flue-gas contaminants, the high-flux polycarbonate membrane has shown gradual permeance loss without loss in selectivity in continuous, seven-day testing. For PVDF-based membranes, the replacement cycle is anticipated to be every 10 years because of the excellent chemical and separation performance stability exhibited by them in the presence of flue-gas contaminants in seven-day tests. Much longer-term contaminant exposure testing of these membranes to real coal-derived flue gas, however, is recommended to confirm/refine the above membrane replacement requirements.

Waste Streams Generated – Because the membrane permeates and concentrates water into the CO₂ capture stream, a liquid water stream is recovered by the membrane process during compression of the capture stream to sequestration pressure. A water condensate stream is also produced upstream of membrane stages M1 and M2 because of compression of their feed gas streams, followed by cooling of this compressed gas with cooling water to the optimum membrane operating temperature. The quality of these liquid water streams is not known and will need to be determined.

technology advantages

Membrane-based processes have the potential to provide PC-fired power plants with a cost-effective technology option for CO₂ capture. They are inherently energy-efficient because the membrane enables passive separation of gases. Their compact footprint and modular nature allows for easy installation into an existing PC-fired plant, and, with no moving parts, they are simple to operate and maintain. In addition, the hollow fiber membrane approach taken in this project is particularly well suited for high-volume applications such as the large flue gas volumes that must be handled in post-combustion carbon capture. Hollow-fiber modules have much higher membrane packing density and lower cost-per-membrane area than other module types. The hollow-fiber membrane tubes are economically produced on a commercial scale by using existing fiber manufacturing equipment technology.

R&D challenges

Flue gas properties, such as low CO₂ concentration of 13 to 15 percent, low flue gas pressure of 1 atm, large flue gas volumes, and the presence of moisture and contaminants (sulfur oxides [SO_x], NO_x, and particulate matter), can pose certain challenges for a conventional membrane separation process. These technology challenges are being addressed in this project through the development of new membrane materials with improved CO₂ separation properties and chemical resistance, improved membrane module design and engineering, and novel process design and integration strategies.

results to date/accomplishments

- Development and scale-up of Generon next-generation, high-flux polycarbonate membrane hollow fibers with up to four times higher CO₂ flux (410 GPU) than that of Generon standard polycarbonate membrane fibers.
 - CO₂/N₂ selectivity of high-flux polycarbonate hollow-fiber membrane was comparable to that of standard (current-generation) polycarbonate hollow-fiber membrane. However, it was only 60 to 70 percent of its intrinsic CO₂/N₂ selectivity (35 to 37), meaning that the high-flux polycarbonate membrane properties could still be improved.
 - Fibers of high-flux polycarbonate with 25 percent larger dimensions were successfully spun as an option for managing parasitic axial pressure drops in the module.
 - High-flux polycarbonate membrane would be best operated at temperatures below room temperature to benefit from substantial increase in CO₂/N₂ selectivity without much decrease in CO₂ permeance due to its weak temperature dependence.
 - High-flux polycarbonate membrane displayed some sensitivity to flue-gas contaminants (NO_x and SO₂), which led to a permeance decline but had minimal to no effect on CO₂/N₂ selectivity. This observed sensitivity did not seem to degrade the membrane as it recovered much of its original properties when the contaminants were removed. In practice, therefore, feed pretreatment should be considered for this membrane.
- Successful formation of Generon high-flux polycarbonate membrane fibers into lab-scale modules and larger prototype (2,200 ft²) modules.
- Development and synthesis of novel Arkema VDF-based copolymers with improved CO₂ permeance and improved CO₂/N₂ selectivity.
 - Copolymerization of a bulky, low-dipole Comonomer A into the VDF chain backbone can increase gas permeability by disrupting chain packing density and crystallinity in the polymer matrix.
 - VDF-co-A copolymer family was developed with up to 17 to 18 times higher CO₂ permeability than the base PVDF homopolymer, while maintaining the CO₂/N₂ selectivity of 24 of the base PVDF.
 - Copolymerization of a bulky, high-dipole Comonomer B into the VDF chain backbone can increase CO₂/N₂ selectivity by enhancing the CO₂ affinity of the polymer while also improving gas permeability relative to the base PVDF homopolymer.

- VDF-co-B copolymer family was developed with 2.5 to 3 times higher CO₂/N₂ selectivity and six times higher CO₂ permeability than base PVDF homopolymer.
- Strong temperature dependence of CO₂ permeance in VDF-based polymers could be exploited as a key process variable for increasing and optimizing CO₂ permeance to increase gas processing throughput in the capture process while maintaining reasonable CO₂ removal.
- VDF-based polymer platform demonstrated excellent stability of its gas separation properties to contaminants SO₂, NO_x, and water vapor.
- Fabrication of the first developmental hollow fibers from new Arkema VDF-based copolymer platform.
 - VDF-A.2 was down-selected for fiber development because it had among the best balance of CO₂ permeability and selectivity of the new copolymers in this fluorinated platform.
 - Synthesis of VDF-A.2 was successfully scaled up to pilot scale to prepare 200 pounds of this resin for fiber development.
 - Fiber tackiness, fiber shape stability, and solvent extraction kinetics were identified as key issues that must be addressed and managed for the VDF-based polymers.
 - Hollow-fiber cores of the VDF-based materials were successfully spun on commercial fiber-spinning equipment. Fibers had good gas flux but exhibited no gas selectivity. Development of a membrane structure with gas selectivity will require additional research and development (R&D) effort.
- Development of three-stage CO₂ capture membrane process design to achieve 90 percent CO₂ capture and 95 percent CO₂ purity.
- Completed techno-economic evaluation of three-stage CO₂ capture membrane process design based on Generon's high-flux polycarbonate hollow-fiber membrane assuming a CO₂ permeance of 400 GPU and CO₂/N₂ selectivity of 35.
 - Increase in levelized cost of electricity (LCOE) estimated for subcritical coal power plant with RTI membrane process was estimated to be ≈73 to 82 percent over that of a plant with no capture, with the LCOE increase depending strongly on compressor cost.
 - Compressor costs made up the majority of equipment costs for the process, with 64 percent of costs attributed to compressors needed for the CO₂ separation process and 10 percent to the compressor for compression/drying of the captured CO₂ product.
 - Cost of CO₂ capture was estimated to be ≈\$42/ton-CO₂.
 - The energy penalty was the biggest contributor to the LCOE.

next steps

This project ended on September 30, 2011.

available reports/technical papers/presentations

“CO₂ Capture Membrane Process for Power Plant Flue Gas,” Final Report, April 2012. <http://www.netl.doe.gov/publications/factsheets/program/05313%20Final%20Report%20April%202012.pdf>.

Toy, L., et al., “CO₂ Capture Membrane Process for Power Plant Flue Gas,” presented at the 2011 NETL CO₂ Capture Technology Meeting, Pittsburgh, Pennsylvania, August 2011. <http://www.netl.doe.gov/File%20Library/Research/Coal/ewr/co2/22Aug11-Toy-RTI-CO2-Capture-Membrane-Process.pdf>.

Toy, L., et al., “CO₂ Capture Membrane Process for Power Plant Flue Gas,” presented at the 2010 NETL CO₂ Capture Technology Meeting, Pittsburgh, Pennsylvania, September 2010. <http://www.netl.doe.gov/File%20Library/Research/Coal/ewr/co2/Lora-Toy--NT0005313.pdf>.

Toy, L., et al., “CO₂ Capture Membrane Process for Power Plant Flue Gas,” presented at the Annual NETL CO₂ Capture Technology for Existing Plants R&D Meeting, Pittsburgh, Pennsylvania, March 2009. <http://www.netl.doe.gov/File%20Library/Research/Coal/ewr/co2/5313-RTI-membrane--Toy--mar09.pdf>.

DEVELOPMENT OF BIOMIMETIC MEMBRANES FOR NEAR-ZERO PC POWER PLANT EMISSIONS

primary project goals

Carbozyme set out to develop an enzyme-based, contained liquid membrane (CLM) to extract carbon dioxide (CO₂) from coal and natural gas combustion flue gas. Carbozyme also set out to evaluate a state-of-the-art electrochemical (EDI) method for CO₂ capture, comparing its performance with that of the CLM.

technical goals

- Scale-up the enzyme-catalyzed, CLM permeator design (4 to 400 m²) to include multiple units organized as a skid (3×40 m²) for testing with various coal ranks and natural gas.
- Implement a pretreatment conditioner to ensure that the flue gas constituents will not adversely impact the CLM permeator.
- Validate technology to cost-effectively produce carbonic anhydrase (CA) enzymes for the CLM.
- Test and analyze three different EDI test cells: a controlled pH resin wafer, a hollow fiber fed bipolar membrane (BPM), and an ion exchange membrane-resin wafer (IEM-RW).
- Conduct a commercialization study for both the CLM and EDI technologies.

technical content

The enzyme-based CA CLM membrane process mimics the natural process for removing CO₂ from an organism. An organism's blood stream is used to transport oxygen (O₂) and CO₂ to and from its cells, respectively. CA is an enzyme in the blood that captures the CO₂ from the cells and converts it to bicarbonate (HCO₃⁻). The enzyme reverses this reaction in the lungs, allowing the CO₂ to be exhaled. Figure 1 shows the configuration for the enzyme-based CA CLM membrane process Carbozyme set out to develop. The CA CLM membrane is able to incorporate the absorption and stripping processes into a single unit. A membrane module consists of two groups of hollow fibers – one group contains the incoming CO₂ lean flue gas, and the second group contains the CO₂ rich permeate stream. The CA enzyme is contained in a thin-film liquid between the two groups of fibers. The CA helps catalyze the CO₂ to HCO₃⁻ to pro-

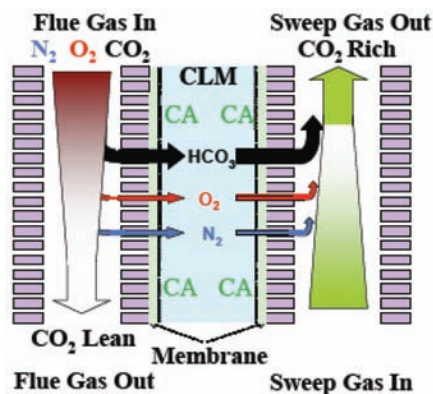

Figure 1: Configuration for Carbozyme-Developed, Enzyme-Based Carbonic Anhydrase Contained Liquid Membrane

technology maturity:

**Laboratory/Bench-Scale,
Using Simulated Flue Gas**

project focus:

Biomimetic Membrane

participant:

Carbozyme

project number:

**FC26-07NT43084
FG26-06NT42824**

NETL project manager:

José Figueroa
jose.figueroa@netl.doe.gov

principal investigator:

Michael Trachtenberg
Carbozyme, Inc.
mct@cz-na.com

partners:

Argonne National Laboratory
EERC
Electrostep
Kansas State University
Siemens
SRI
Visage Energy

performance period:

3/28/07 – 7/31/09

mote permeation across the CO₂ lean membrane and reverses the process, promoting permeation across the CO₂-rich membrane. CA is one of the fastest acting enzymes with a turnover rate of 600,000 katals (catalyzes the hydration of 600,000 molecules of CO₂ per second per molecule of CA).

Figure 2 shows a process schematic for the CA CLM. Pretreated combustion flue gas from the boiler enters the membrane. A vacuum system is used to provide the driving force across the membrane. After the CO₂ is separated from the flue gas, it goes through a knockback condenser for water removal prior to compression. The resulting product is a 95 percent pure CO₂ stream. The remaining flue gas is sent to the plant stack.

The concentrated ammoniated solution is used to capture CO₂ and hydrogen sulfide (H₂S) from synthesis gas (syngas) at high pressure. This technique reduces the size of the CO₂ stripper and operates at high pressure, reducing CO₂ compression needs; both reduce electric power consumption. AC has high net CO₂ loading, is a low-cost and readily available reagent, and requires little solvent makeup; the solubility of hydrogen (H₂), carbon monoxide (CO), and methane (CH₄) in absorber solution is extremely low.

The project, in its first phase, constructed a bench-scale batch reactor unit to test the technology at SRI's facility in California. Testing was performed to validate the concept and to determine the optimum operating conditions.

Absorber testing was conducted to first determine the solubility of shifted-gas components (H₂, CO, nitrogen [N₂], argon [Ar]), then to determine the reactivity of CO₂ and H₂S; mixed-gas testing was performed to determine the relative reaction kinetics.

Regenerator testing was conducted to determine CO₂ and H₂S release characteristics, as well as the relative kinetics of CO₂ and H₂S release. Optimal operating conditions derived in bench-scale testing will be used at the pilot-scale test.

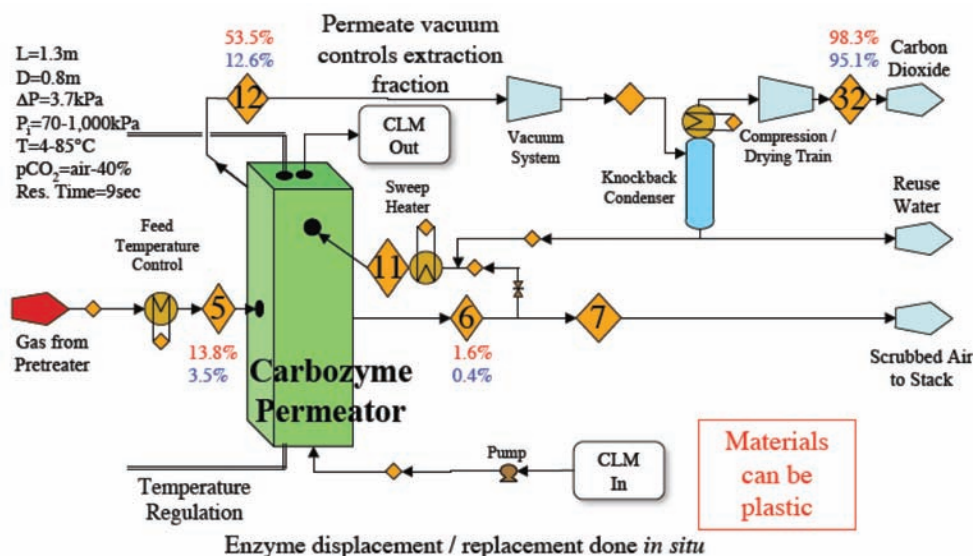

Figure 2: Process Schematic for the Carbonic Anhydrase Contained Liquid Membrane

technology advantages

- The CA enzyme catalyst does not contain any toxic chemicals or byproducts, making it more environmentally friendly than competing technologies.
- The CA enzyme catalyst has a fast CO₂ production rate with low energy requirements and boosts separation and purification due to its low nitrogen (N₂) and O₂ solubility.
- The enzyme catalyst is not vulnerable to oxidation or the formation of stable salts.
- The CA CLM system requires only minimal pumping and no heat exchangers, allowing it to consume 30 to 50 percent less energy compared to competing technologies.
- The CA CLM system recycles nearly all of its water and a portion of its waste heat.
- The modular design of the membrane makes it easy to manufacture, install, and scale up.

R&D challenges

- The cost of the purified CA enzyme remains high and production costs will need to be reduced in order to be considered economically viable.
- Early immobilization of the CA enzyme needs to be addressed.
- Sulfur dioxide (SO₂) acidification of the carbonate carrier fluid needs to be addressed via flue gas pretreatment.
- Ionized mercury in the flue gas could reduce enzyme activity.

results to date/accomplishments

Development progress for the CA CLM process was made in several categories, such as flue gas stream analysis and conditioning, enzyme selection, enzyme immobilization, membrane module construction, and economic analysis.

Specific accomplishments include:

- Developed an immobilized CA enzyme catalyst based on a thermophilic form of CA that can maintain a high activity at elevated temperature ($\approx 50^{\circ}\text{C}$). The enzyme was immobilized using a proprietary surface activation method using an ultrathin polyamino acid (PAA) layer that can be removed and replaced, as needed. Enzyme testing indicated up to 80 percent of initial activity was retained over a 60-day period.
- Developed a 0.5-m² bench-scale CLM permeator that combines absorption and desorption in a single house through use of dual hollow-fiber, spiral-wound, polymer membranes. In this configuration, CO₂ capture is driven by a combination of pressure, vacuum, and temperature. More than 90 percent CO₂ capture was achieved during testing.
- Developed an alternate process technology based on separate absorption/desorption modules using single hollow-fiber, spiral-wound, polymer membranes.
- Fabricated an 11-m² CLM module for scale-up testing.
- Developed and tested a flue gas pre-treatment system for the CLM process.
- Developed computer modeling for CLM process components and integrated systems.
- Developed and tested a second technology based on a resin-wafer EDI system that uses a pH shift to accomplish CO₂ absorption/desorption.

next steps

This project ended on July 31, 2009.

[available reports/technical papers/presentations](#)

“Development of Biomimetic Membranes for Near Zero PC Power Plant Emissions,” Final Report for Project #43084, March 2011.

“Capture of CO₂ by the Carbozyme Permeator,” 8th Annual Conference on Carbon Capture and Sequestration, Pittsburgh, Pennsylvania, May 2009.

“Development of Biomimetic Membranes for Near-Zero Power Plant Emissions,” Annual NETL CO₂ Capture Technology for Existing Plants R&D meeting, Pittsburgh, Pennsylvania, March 2009.

“Membrane-based, Enzyme Facilitated, Efficient, Carbon Dioxide Capture,” 9th International Conference on Greenhouse Gas Control Technologies, Washington, DC, November 2008.

“Progress on Carbozyme’s HFCLM Permeator Technology Scale-up Project,” 7th Annual Conference on Carbon Capture and Sequestration, Pittsburgh, Pennsylvania, May 2008.

“Biomimetic Membrane for CO₂ Capture from Flue Gas,” Final Report for Project #42824, August 2007.

NOVEL DUAL FUNCTIONAL MEMBRANE FOR CONTROLLING CARBON DIOXIDE EMISSIONS FROM FOSSIL-FUELED POWER PLANTS

primary project goals

The University of New Mexico set out to develop a new, dual-functional, silica-based membrane for carbon dioxide (CO₂) emissions capture from coal-fired power plants.

technical goals

- Achieve a membrane CO₂/nitrogen (N₂) selectivity of 100 and a CO₂ permeance of 1,000 gas permeance units (GPU) or greater.
- Formulate a sol-gel composition to be used in the preparation of clear aminosilicate coatings for membrane deposition onto the siliceous support matrix.
- Setup multi-component gas separation tests for preliminary membrane performance analysis.
- Refine the sol-gel compositions for optimal membrane deposition.
- Study the influence of sulfur dioxide (SO₂), water vapor, and trace oxygen (O₂) on membrane performance.
- Optimize membrane deposition on alternative economical membrane supports.
- Conduct preliminary economic analysis of the membrane process for post-combustion CO₂ capture.
- Identify a processing window that allows reproducible preparation of an asymmetric microporous silica membrane.
- Stabilize membrane performance through a nickel (Ni)-doping approach.
- Prepare an ultra-thin silica membrane using a plasma-assisted, atomic layer deposition technique (PA-ALD).

technical content

The dual-functional, silica-based membrane is prepared by a unique sol-gel dip-coating process for depositing a microporous amino-silicate membrane on a porous tubular ceramic support. It consists of a microporous inorganic siliceous matrix, with amine functional groups

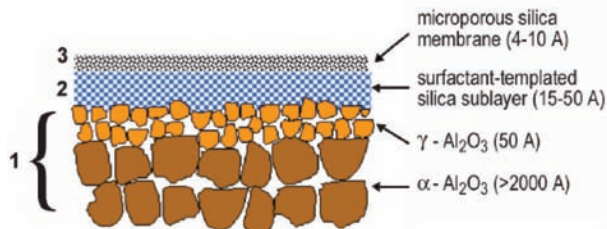

Figure 1: Cross-Section of Membrane

technology maturity:

Laboratory-Scale, with Simulated Flue Gas

project focus:

Dual Functional, Silica-Based Membrane

participant:

University of New Mexico

project number:

FG26-04NT42120

NETL project manager:

José Figueroa
jose.figueroa@netl.doe.gov

principal investigator:

C. Jeffrey Brinker
University of New Mexico
cjbrink@sandia.gov

partners:

T3 Scientific LLC

performance period:

8/23/04 – 4/30/09

physically immobilized or covalently bonded on the membrane pore walls. Strong interactions between the permeating CO₂ molecules and the amine functional membrane pores enhance surface diffusion of CO₂ on the pore wall of the membrane, subsequently blocking other gases. The membrane is composed of three distinct layers as shown in Figure 1: (1) a commercially available tubular or hollow-fiber ceramic support; (2) a mesoporous surfactant-templated silica sub-layer with pore size 15-50 Å; and (3) a microporous aminosilicate gas separation membrane layer with pore size 4-10 Å.

TABLE 1: MEMBRANE PROCESS PARAMETERS

	Units	Current R&D Value	Target R&D Value
Materials Properties			
Materials of Fabrication for Selective Layer	-	Aminosilicate/doped-silicate	
Materials of Fabrication for Support Layer	-	Surfactant-templated silica on alumina	
Nominal Thickness of Selective Layer	µm		
Membrane Geometry	-	Plate-and-frame	Hollow-fiber
Max Trans-Membrane Pressure	bar	3 bar	N/A
Hours Tested Without Significant Degradation	-	168 hrs	100 hrs
Manufacturing Cost for Membrane Material	\$/m ²		
Membrane Performance			
Temperature	°C	25 – 250°C	25 – 80°C
CO ₂ Pressure Normalized Flux	GPU or equivalent	CO ₂ : 400 GPU	CO ₂ : 1,000 GPU
CO ₂ /H ₂ O Selectivity	-		
CO ₂ /N ₂ Selectivity	-	CO ₂ /N ₂ =80-100 (dry feed); CO ₂ /N ₂ = 50-60 (humidified feed)	CO ₂ /N ₂ = 100
CO ₂ /SO ₂ Selectivity	-		
Type of Measurement	-	Mixed gas	Mixed gas
Proposed Module Design			
Flow Arrangement	-		
Packing Density	m ² /m ³	980	
Shell-Side Fluid	-		
Flue Gas Flowrate	kg/hr		
CO ₂ Recovery, Purity, and Pressure	% / % / bar	>90%	
Pressure Drops Shell/Tube Side	bar	0.01 – 0.02	
Estimated Absorber/Stripper Cost of Manufacturing and Installation	$\frac{\$}{\text{kg/hr}}$		

Definitions:

Membrane Geometry – Flat discs or sheets, hollow fibers, tubes, etc.

Pressure Normalized Flux – For materials that display a linear dependence of flux on partial pressure differential, this is equivalent to the membrane's permeance.

GPU – Gas Permeation Unit, which is equivalent to 10⁻⁶ cm³ (1 atm, 0°C)/cm²/s/cm Hg. For non-linear materials, the dimensional units reported should be based on flux measured in cm³ (1 atm, 0°C)/cm²/s with pressures measured in cmHg. Note: 1 GPU = 3.3464×10⁻⁶ kg mol/m²-s-kPa [SI units].

Type of Measurement – Either mixed or pure gas measurements; target permeance and selectivities should be for mixture of gases found in de-sulfurized flue gas.

Flow Arrangement – Typical gas-separation module designs include spiral-wound sheets, hollow-fiber bundles, shell-and-tube, and plate-and-frame, which result in either co-current, counter-current, cross-flow arrangements, or some complex combination of

these.

Packing Density – Ratio of the active surface area of the membrane to the volume of the module.

Shell-Side Fluid – Either the permeate (CO₂-rich) or retentate (flue gas) stream.

Estimated Cost – Basis is kg/hr of CO₂ in CO₂-rich product gas; assuming targets are met.

Other Parameter Descriptions:

Contaminant Resistance – SO₂ > 10 parts per million (ppm).

Flue Gas Pretreatment Requirements – Particulate removal.

Waste Streams Generated – None.

technology advantages

The dual-functional, silica-based membrane will have a higher CO₂ selectivity and permeance compared to conventional membranes that separate gases based on differences in molecular size only.

R&D challenges

- The permeance of the new membrane will need to be increased by a factor of five to meet the research and development (R&D) target.
- The selectivity for the new membrane must remain constant under temperatures of 50 to 70°C and high humidity conditions.
- The presence of particulates in the flue gas could adversely affect membrane performance.
- Previous membrane designs suffered from a gradual reduction in permeance and selectivity under elevated temperature and humidity conditions due to pore shrinkage/blockage.

results to date/accomplishments

- Three classes of microporous, sol-gel derived, silica-based membranes were developed for CO₂ removal under simulated flue gas conditions.
- A novel class of amine-functional, microporous silica membranes was prepared using an amine-derivatized alkoxy silane precursor, exhibiting enhanced CO₂:N₂ selectivity (>70) in the presence of water vapor, but its CO₂ permeance (<1.25 cm³[STP]/cm²-min-atm [\approx 275 GPU]) was below the target.
- Pure siliceous membranes showed higher CO₂ permeance (1.5-2 cm³[STP]/cm²-min-atm [\approx 330-440 GPU]), but subsequent densification occurred under prolonged simulated flue gas conditions.
- Nickel oxide (NiO) was incorporated into the membrane's microporous network to retard densification and achieved CO₂ permeance of 0.5 cm³(STP)/cm²-min-atm (\approx 110 GPU) and CO₂:N₂ selectivity of \approx 50 after 163 hours exposed to simulated flue gas conditions.
- The implementation of a novel ALD processing scheme shows evidence that a vapor-processed membrane can exhibit higher thermal/structural stability combined with higher flux and selectivity compared to the traditional liquid phase processing approach (sol-gel).

next steps

This project ended on April 30, 2009.

available reports/technical papers/presentations

“Novel Dual-Functional Membrane for Controlling Carbon Dioxide Emissions from Fossil Fuel Power Plants,” Final Scientific/Technical Report, August 2009. <http://www.netl.doe.gov/File%20Library/Research/Coal/ewr/co2/2009Novel-Dual-Functional-Membrane-for-Controlling-Carbon-Di.pdf>.

“Tubular Ceramic-Supported Sol-Gel Silica-Based Membranes for Flue Gas Carbon Dioxide Capture and Sequestration,” *J. Memb. Sci.*, 341 (2009) 30-36.

“Novel Dual-Functional Membrane for CO₂ Capture,” Seventh Annual Carbon Capture and Sequestration Conference, Pittsburgh, Pennsylvania, May 2008.

“Anodic Alumina Supported Dual-Layer Microporous Silica Membranes,” *J. Memb. Sci.*, 287, (2007) 157-161.

“Microporous Sol-Gel Derived Aminosilicate Membrane for Enhanced Carbon Dioxide Separation,” *Separation and Purification Technology*, 42(3) (2005) 249-257.

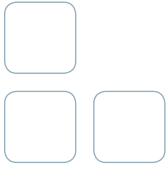

PRE-COMBUSTION SOLVENT TECHNOLOGIES



CO₂ CAPTURE FROM IGCC GAS STREAMS USING AC-ABC PROCESS

primary project goals

With a goal towards improved process efficiency and reduced cost of capture, SRI International (SRI) is developing a carbon dioxide (CO₂) capture technology for integrated gasification combined cycle (IGCC)-based power plants that uses a high-capacity and low-cost aqueous solution containing ammonium carbonate (AC) that reacts with CO₂ to form ammonium bicarbonate (ABC). SRI has partnered with Bechtel Hydrocarbon Technology Solutions (BHTS) to use the Bechtel Pressure Swing Claus (BPSC) process to remove sulfur species from the recovered CO₂ stream.

technical goals

- Test the technology on a bench-scale batch reactor to validate the concept.
- Determine the optimum operating conditions for a small pilot-scale reactor.
- Design and build a small pilot-scale reactor capable of continuous, integrated operation.
- Perform pilot-scale tests to evaluate the process in a coal gasifier environment.
- Perform a technical and economic evaluation of the technology.

technical content

The technology is based on the use of an aqueous ammoniated solution containing AC, which reacts with CO₂ to form ABC.

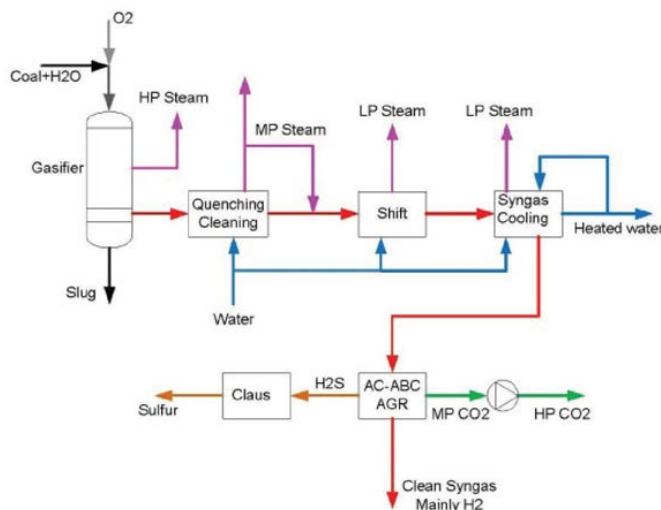

Figure 1: Acid Gas Removal in Gasification System

technology maturity:

Pilot-Scale Using Actual Syngas

project focus:

CO₂ Capture Using AC-ABC Process

participant:

SRI International

project number:

FE0000896

NETL project manager:

Elaine Everitt

elaine.everitt@netl.doe.gov

principal investigator:

Anoop Nagar

SRI International

anoop.nagar@sri.com

partners:

Eli Gal

Bechtel Hydrocarbon

Technology Solutions, Inc.

National Carbon Capture

Center

performance period:

9/30/09 – 9/30/15

The concentrated ammoniated solution is used to capture CO₂ and hydrogen sulfide (H₂S) from synthesis gas (syngas) at high pressure. This high pressure separation technique reduces the size of the CO₂ stripper, the CO₂ compression needs, and the electric power consumption.

AC is a low-cost and readily available reagent with high net CO₂ loading capacity requiring relatively low circulation of solvent between the CO₂/H₂S absorber and CO₂/H₂S stripper. The ammonium carbonate is highly selective to CO₂ and H₂S and; the solubility of hydrogen (H₂), carbon monoxide (CO), and methane (CH₄) in the absorber solution is extremely low, resulting in minimal losses of syngas species in the absorber and in high purity CO₂/H₂S stream from the stripper.

In the first phase of the project, a bench-scale batch-reactor unit was constructed at SRI's facility in California, and testing was performed to validate the concept and determine the optimum operating conditions.

The absorber testing was conducted to determine the solubility of shifted-gas components (H₂, CO, nitrogen [N₂], argon [Ar]) and then the reactivity of CO₂ and H₂S; mixed-gas testing was performed to evaluate the relative reaction kinetics.

Regenerator testing was conducted to determine CO₂ and H₂S release characteristics, as well as the relative kinetics of CO₂ and H₂S release. Optimal operating conditions derived in bench-scale testing will be used for the pilot-scale test.

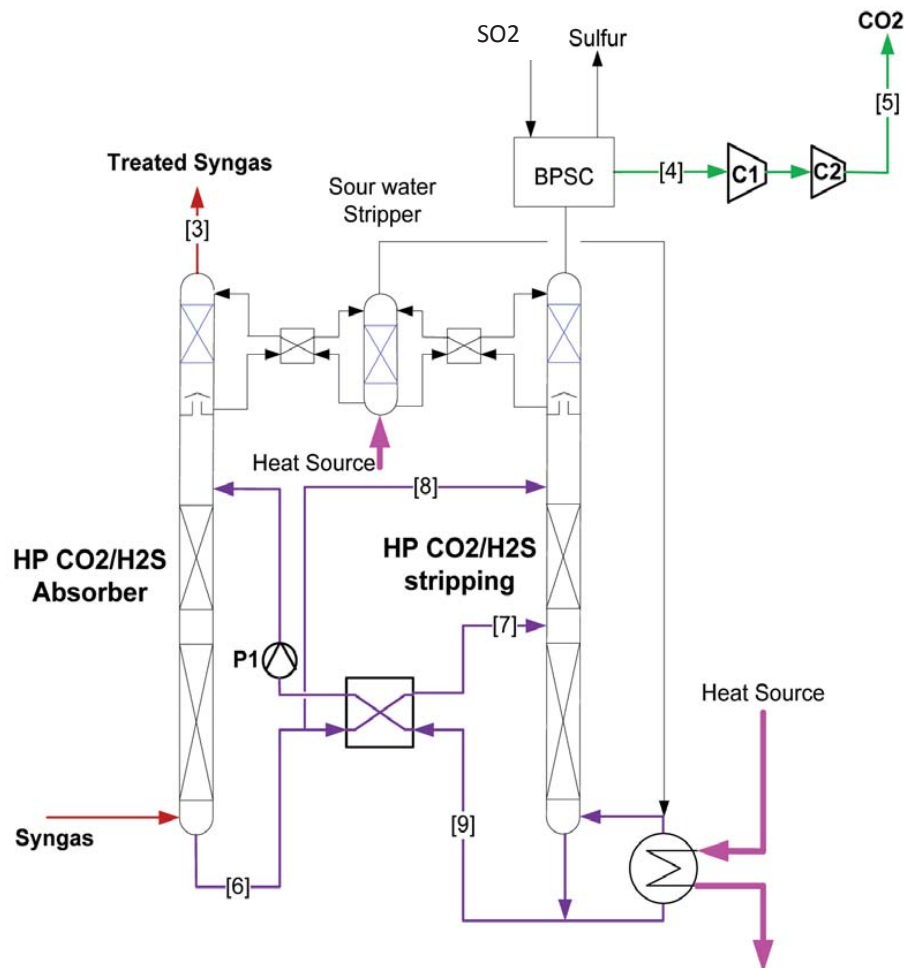

Figure 2: Schematic of the CO₂ and H₂S Capture System

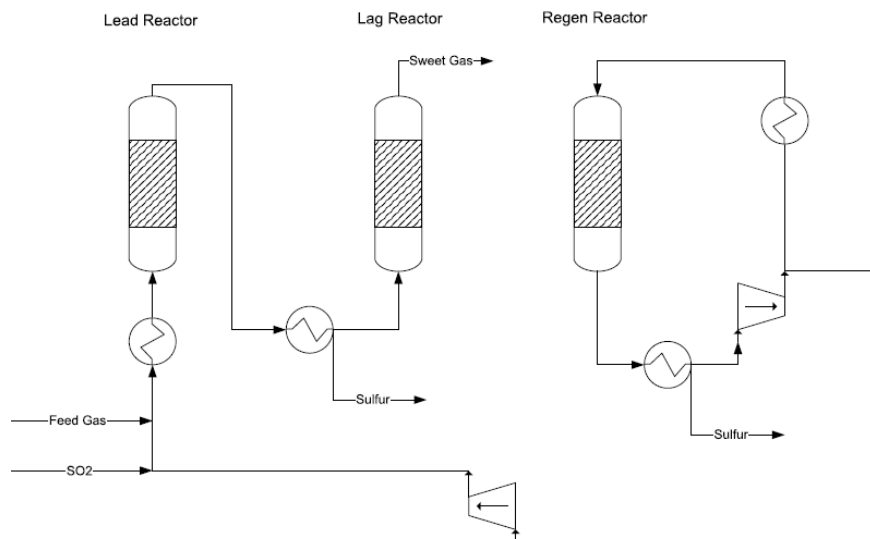

Figure 2a: Schematic of the Bechtel Pressure Swing Claus H₂S Removal System

The BPSC (Bechtel Pressure Swing Claus) unit operates, in this case, after the AC-ABC unit. BPSC is a high pressure, sub-dewpoint Claus system which recovers H₂S directly from the syngas in the form of elemental molten sulfur.

Pilot-scale testing of AC-ABC and BPSC will be performed on a slipstream from the air-blown gasifier at the National Carbon Capture Center (NCCC) in Wilsonville, Alabama. SRI has designed a pilot-scale, continuous, integrated test system, and the equipment has been procured and assembled. The pilot-scale test will emphasize stability of integrated operation. The effects of trace contaminants will be assessed, as the pilot tests will use a gas stream from an operating gasifier that has undergone minimum cleanup and will contain trace contaminants.

A preliminary technical and economic analysis was performed using Aspen and GT-Pro programs to generate the equipment sizing and heat and material flows, DOE cost models, and a base case, 750-MW nominal IGCC plant without CO₂ capture to compare the AC-ABC and BPSC processes with a similarly sized plant using CO₂ capture with Selexol and traditional Claus subsystem.

TABLE 1: SOLVENT PARAMETERS

	Units	Current R&D Value	Target R&D Value
Pure Solvent			
Molecular Weight	mol ⁻¹	nominal 18	nominal 18
Normal Boiling Point	°C	varies with pressure: 100 °C at 1 atm	varies with pressure: 100 °C at 1 atm
Normal Freezing Point	°C	nominal 0 °C, varies with composition	nominal 0 °C, varies with composition
Vapor Pressure at 15 °C	bar	NH ₃ vapor pressure varies with composition and temperature,	NH ₃ vapor pressure varies with composition and temperature
Manufacturing Cost for Solvent	\$/kg		cost of anhydrous ammonia typically \$200–\$400/ton
Working Solution			
Concentration	kg/kg	0.1 kg NH ₃ /kg	0.15 kg NH ₃ /kg
Specific Gravity (15 °C/15 °C)	—	1.1	1.1
Specific Heat Capacity at STP	kJ/kg-K	3.5	3.5
Viscosity at STP	cP	nominal 1	nominal 1

Absorption			
Pressure	bar	20	30
Temperature	°C	25	25–40
Equilibrium CO ₂ Loading	mol/mol	varies with the composition of the solution	varies with the composition of the solution
Heat of Absorption	kJ/mol CO ₂		40–60
Solution Viscosity	cP	nominal 1	nominal 1
Desorption			
Pressure	bar	30	30
Temperature	°C	<200 °C	
Equilibrium CO ₂ Loading	mol/mol	varies with the composition of the solution	varies with the composition of the solution
Heat of Desorption	kJ/mol CO ₂		TBD
Proposed Module Design		<i>(for equipment developers)</i>	
Syngas Flowrate	kg/hr	225	
CO ₂ Recovery, Purity, and Pressure	%%/bar	90 %, >95 %, 30 bar	
Absorber Pressure Drop	bar	<1 bar	

Definitions:

STP – Standard temperature and pressure (15 °C, 1 atm).

Pure Solvent – Chemical agent(s), working alone or as a component of a working solution, responsible for enhanced CO₂ absorption (e.g., the amine monoethanolamine [MEA] in an aqueous solution).

Manufacturing Cost for Solvent – “Current” is market price of chemical, if applicable; “Target” is estimated manufacturing cost for new solvents or the estimated cost of bulk manufacturing for existing solvents.

Working Solution – The solute-free (i.e., CO₂-free) liquid solution used as the working solvent in the absorption/desorption process (e.g., the liquid mixture of MEA and water).

Absorption – The conditions of interest for absorption are those that prevail at maximum solvent loading, which typically occurs at the bottom of the absorption column. These may be assumed to be 1 atm total flue-gas pressure (corresponding to a CO₂ partial pressure of 0.13 bar) and 40 °C; however, measured data at other conditions are preferable to estimated data.

Desorption – The conditions of interest for desorption are those that prevail at minimum solvent loading, which typically occurs at the bottom of the desorption column. Operating pressure and temperature for the desorber/stripper are process-dependent (e.g., an MEA-based absorption system has a typical CO₂ partial pressure of 1.8 bar and a reboiler temperature of 120 °C). Measured data at other conditions are preferable to estimated data.

Pressure – The pressure of CO₂ in equilibrium with the solution. If the vapor phase is pure CO₂, this is the total pressure; if it is a mixture of gases, this is the partial pressure of CO₂. Note that for a typical pulverized-coal power plant, the total pressure of the flue gas is about 1 atm and the concentration of CO₂ is about 13.2 percent. Therefore, the partial pressure of CO₂ is roughly 0.132 atm or 0.130 bar.

Concentration – Mass fraction of pure solvent in working solution.

Loading – The basis for CO₂ loadings is moles of pure solvent.

Estimated Cost – Basis is kg/hr of CO₂ in CO₂-rich product gas; assuming targets are met.

Other Parameter Descriptions:

Chemical/Physical Solvent Mechanism –

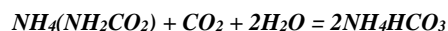
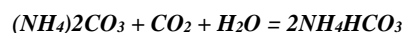
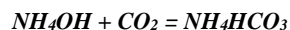

Solvent Contaminant Resistance – The solvent is expected to be resistant to several contaminants nominally present in an IGCC gas stream. Hydrogen sulfide reacts with the solvent, but it can be removed during the regeneration. The ammonia (NH₃) in the IGCC may negate any NH₃ loss from the solvent. The resistance of the solvent to trace metals is not known yet.

Solvent Foaming Tendency – Solvent foaming tendency was not observed in the bench-scale tests.

Syngas Pretreatment Requirements – The IGCC gas stream needs to undergo a water-gas shift (WGS) reaction to convert CO to CO₂ and to be cooled to a temperature of 25–50 °C.

Solvent Makeup Requirements – The AC is a readily available commodity chemical, and the makeup requirements are estimated to be small. However, the actual amount will be determined in the field test.

Waste Streams Generated – Ammonium sulfate solution from the capture of trace residual NH₃ in the gas.

technology advantages

- Low-cost and stable reactive solution.
- Reactive solution has a high CO₂ loading capacity. CO₂ stripping in the AC-ABC process can be accomplished at elevated pressures in the range of 20–50 bar, resulting in a 3 to 7.5 pressure ratio to compress the gas to the pipeline pressure of 150 bar pressure.
- The AC-ABC process does not require compressors other than the CO₂ compressor.
- High CO₂ loading and high-pressure CO₂ stripper reduces the pumping power between the absorber and the regenerator.
- The AC-ABC process does not require high conversion of CO in the syngas feed to achieve 90 percent reduction of carbon emission.
- Hot syngas from the shift reactor can be used as the main heat source for the CO₂ stripping, reducing the power output penalty.
- The BPSC process removes H₂S from the high-pressure CO₂ (or syngas) stream with minimal reduction in pressure, which reduces the power output penalty.
- The BPSC process combines the function of three units (solvent, Claus, and Claus tail gas) into one. The thermal oxidizing unit needed for the traditional approach is not needed with BPSC, reducing total carbon footprint.

R&D challenges

- Absorber operation at an elevated temperature could create excessive residual ammonia in the fuel gas stream leaving the absorber.
- Adequate separation of H₂S and CO₂ may be difficult to obtain using AC-ABC alone.
- The long-term effects of contaminants present in syngas on the AC-ABC system and the BPSC catalyst are unknown.

results to date/accomplishments

- Bench-scale mixed-gas batch tests were conducted with various gas compositions. Carbon dioxide and H₂S capture rates were experimentally determined as a function of temperature, pressure, and solution and gas compositions. Data from regenerator experiments were used to determine the optimum regenerator conditions for the release of CO₂ and H₂S exclusively.

- The bench-scale tests demonstrated an efficient absorption of CO₂ and H₂S at elevated pressures without the need for sub-ambient operation. High-pressure CO₂ and concentrated H₂S streams can be released during the regeneration of loaded solution.
- The design of the pilot-scale continuous, integrated AC-ABC test system, designed to run on a coal-derived syngas, has been finalized.
- Assembly of pilot-scale integrated AC-ABC unit is underway.

next steps

Test the AC-ABC test system using the gasifier syngas stream at the NCCC.

available reports/technical papers/presentations

“CO₂ Capture from IGCC Gas Streams Using AC-ABC Process,” presented at the 2014 NETL CO₂ Capture Technology Meeting, Pittsburgh, PA, July 2014. <http://www.netl.doe.gov/File%20Library/Events/2014/2014%20NETL%20CO2%20Capture/G-Krishnan-SRI-IGCC-Gas-Streams.pdf>.

“CO₂ Capture from IGCC Gas Streams Using AC-ABC Process,” presented at the 2013 NETL CO₂ Capture Technology Meeting, Pittsburgh, PA, July 2013. <http://www.netl.doe.gov/File%20Library/Events/2013/CO2%20Capture/G-Krishnan-SRI-AC-ABC-Process.pdf>.

“CO₂ Capture from IGCC Gas Streams Using AC-ABC Process,” presented at the 2012 NETL CO₂ Capture Technology Meeting, Pittsburgh, PA, July 2012. <http://www.netl.doe.gov/File%20Library/Events/2012/CO2%20Capture%20Meeting/I-Jayaweera-SRI-AC-ABC-Process.pdf>.

“CO₂ Capture from IGCC Gas Streams Using AC-ABC Process,” presented at the 2011 NETL CO₂ Capture Technology Meeting, Pittsburgh, PA, August 2011. <http://www.netl.doe.gov/File%20Library/Events/2011/CO2capture/25Aug11-Jayaweera-SRI-AC-ABC-Process.pdf>.

“CO₂ Capture from IGCC Gas Streams Using AC-ABC Process,” presented at the 2010 NETL CO₂ Capture Technology Meeting, Pittsburgh, PA, September 2010. <http://www.netl.doe.gov/File%20Library/Events/2010/CO2capture/Gopala-Krishnan---FE0000896.pdf>.

“CO₂ Capture from IGCC Gas Streams Using the AC-ABC Process,” presented at the Pre-Combustion CO₂ Capture Kick-Off Meetings, Pittsburgh, PA, November 2009.

“Analysis of SRI AC-ABC and Bechtel Pressure Swing Claus Technologies for Pre-Combustion Carbon Capture,” presented at the Eleventh Annual Conference on Carbon Capture, Utilization and Sequestration, Pittsburgh, PA, May 2012.

“Bechtel Pressure Swing Claus Sulfur Recovery,” presented at the International Pittsburgh Coal Conference, Pittsburgh, PA, September 2009.

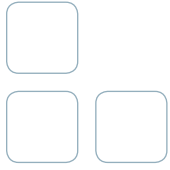

PRE-COMBUSTION SORBENT TECHNOLOGIES



PILOT TESTING OF A HIGHLY EFFECTIVE PRE-COMBUSTION SORBENT-BASED CARBON CAPTURE SYSTEM

primary project goals

TDA is continuing development of a new sorbent-based pre-combustion carbon capture technology for integrated gasification combined cycle (IGCC) power plants. The process uses an advanced physical adsorbent that selectively removes CO₂ from coal derived synthesis gas (syngas) above the dew point of the gas.

Having shown promise under a previously-funded DOE project (FE0000469), this sorbent is being evaluated at a larger scale, for longer durations, and under conditions that are more representative of a coal gasification based application. The objective of the research is to collect performance data for this advanced sorbent including: two 0.1 MWe tests with a fully-equipped prototype unit using actual synthesis gas to prove the viability of the new technology; long-term sorbent life evaluation in a bench-scale setup of 20,000 cycles; the fabrication of a pilot-scale testing unit that will contain eight sorbent reactors; and the design of a CO₂ purification sub-system. The CO₂ removal technology is projected to improve the IGCC process efficiency (3–4 percent) needed for economically viable production of power from coal.

technical goals

- Design and fabricate a 0.1-MW_e pilot-scale separation system for pre-combustion CO₂ capture using a functionalized carbon sorbent.
- Develop multicomponent adsorption model.
- Update process design and simulation.
- Complete two pilot-scale field tests at the National Carbon Capture Center (NCCC) and at Sinopec's IGCC plant.
- Complete long-term bench-scale sorbent life testing.
- Perform techno-economic evaluation to accurately estimate cost of CO₂ capture.
- Complete Environmental, Health, and Safety (EHS) assessment.

technical content

TDA Research is designing, constructing, and operating a slipstream 0.1-MW_e pilot-scale process for pre-combustion CO₂ capture to assess their novel adsorbent for the selective removal of CO₂. The adsorbent consists of a mesoporous carbon grafted with surface functional groups that remove CO₂ via an acid-base interaction. The novel process is based on TDA's high-temperature pressure swing adsorption (PSA) technology using the new adsorbent to selectively remove CO₂ from synthesis gas in an IGCC power plant. The integration of the CO₂ separation unit into the IGCC plant is shown in Figure 1.

technology maturity:

Pilot-Scale, Actual Syngas Slipstream (0.1 MW_e)

project focus:

High Capacity Regenerable Sorbent

participant:

TDA Research, Inc.

project number:

FE0013105

NETL project manager:

Elaine Everitt
elaine.everitt@netl.doe.gov

principal investigator:

Gokhan Alptekin
TDA Research, Inc.
galptekin@tda.com

partners:

Gas Technology Institute
Illinois Clean Coal Institute
University of California at Irvine (UCI)
University of Alberta
Sinopec

performance period:

10/1/13 – 9/30/17

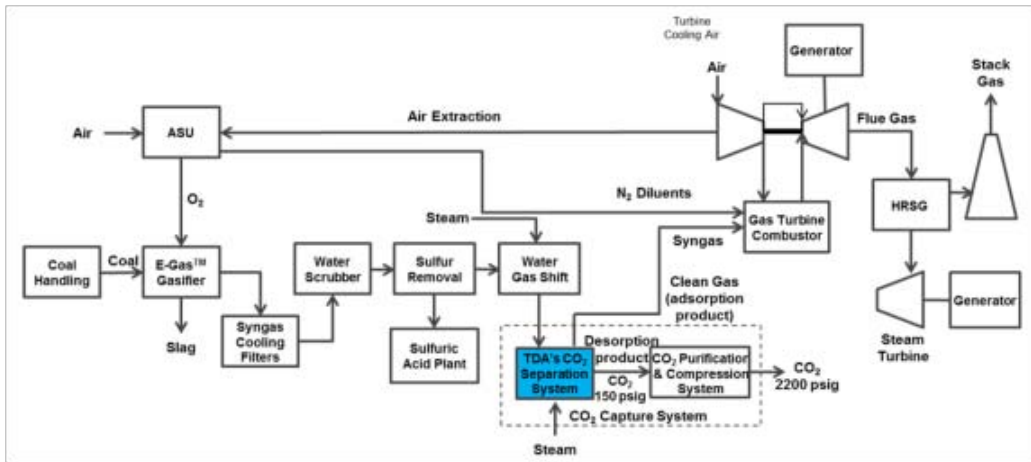

Figure 1: TDA's CO₂ Capture System Integration in IGCC Power Plant

The CO₂ capture system uses multiple sorbent beds that switch operating modes between adsorption and regeneration. In addition to the conventional pressure and temperature swing operation, the sorbent can be regenerated under near isothermal and isobaric conditions, while the driving force for separation is provided by a swing in CO₂ concentration. The sorbent removes CO₂ via strong physical adsorption. The CO₂ surface interaction is strong enough to allow operation at elevated temperatures. Because the CO₂ is not bonded via a covalent bond, the energy input to the regeneration is low—only 3.8–4.9 kcal/mole of CO₂ removed (comparable to Selexol™). This energy requirement is much lower than that of the chemical absorbents (e.g., sodium carbonate [Na₂CO₃] requires 29.9 kcal/mol) and amine solvents (≈14 kcal/mol). The energy output loss of the IGCC plant is expected to be similar to that of Selexol's; however, a higher overall IGCC efficiency can be achieved due to higher temperature CO₂ capture.

The pilot plant design includes a gas conditioning unit and a high temperature pressure swing adsorption based CO₂ separation unit, as shown in Figure 2. The gas conditioning unit allows for adjustment of the concentration and purity of the synthesis gas. The CO₂ separation unit consists of eight high-temperature sorbent beds. The 3-D design of the 8-bed CO₂ capture skid is shown in Figure 3.

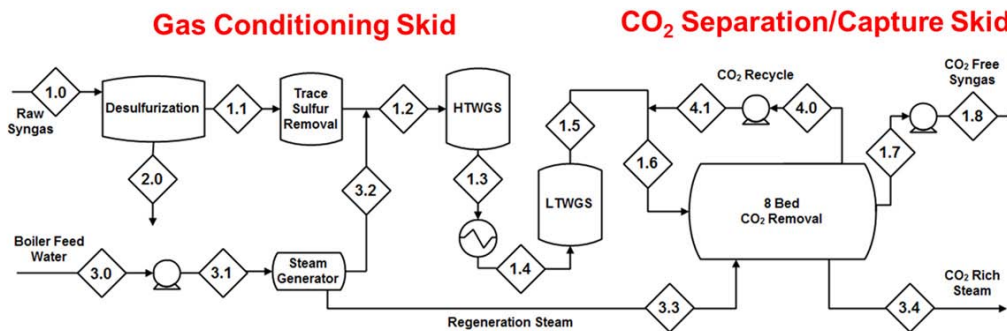

Figure 2: Flow Diagram for TDA's Pilot Test Unit

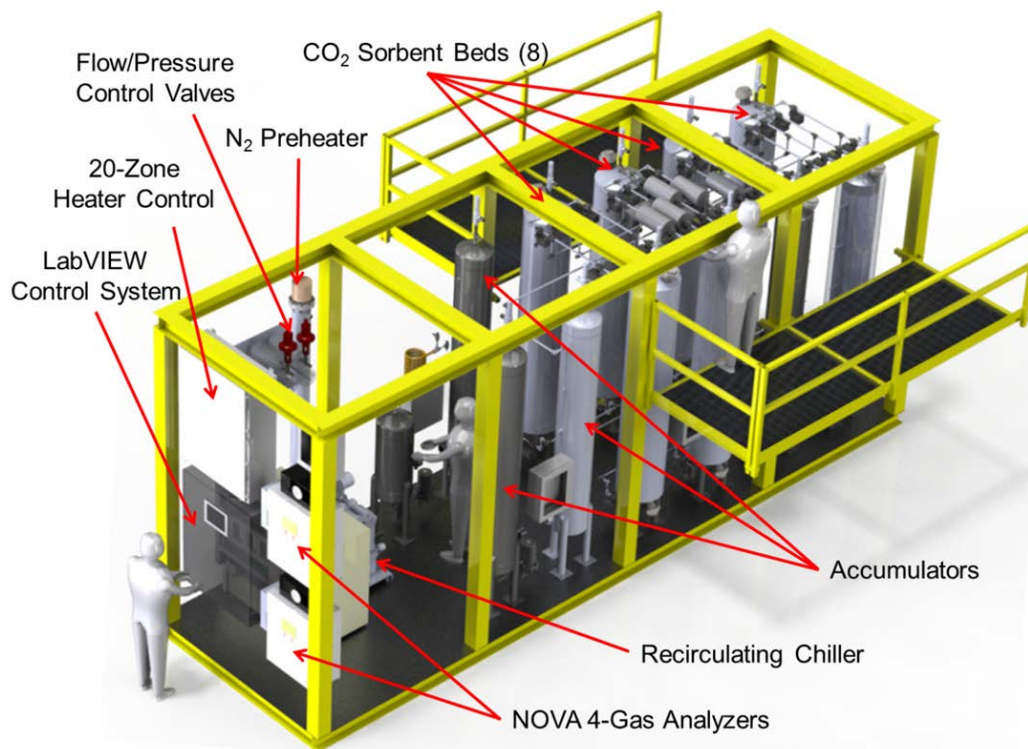

Figure 3: 3-D Layout of the Carbon Capture Skid

The project aims to prove the viability of the new technology by using data collected from the pilot plant tests to complete high fidelity engineering and cost analyses to calculate the impact of the carbon capture system on the cost of electricity generation at a coal-fired IGCC power plant and the potential of the technology to meet the DOE goals of 90 percent CO₂ capture and 95 percent purity at a cost of less than \$40/tonne CO₂ captured.

technology advantages

- Warm gas CO₂ capture above dew point of syngas leads to more steam in the hydrogen rich gas entering the turbine.
 - Improved efficiency.
 - Higher mass throughput to gas turbine.
 - Lower gas turbine temperature lowers need for high pressure N₂ dilution and lower NO_x formation.
- High steam content feed more suited for next generation hydrogen turbines under development.
- High working capacity and cycle life of sorbent.
- Carbon dioxide recovered at pressure reduces compression costs for sequestration.
- A weak CO₂ surface interaction allows fast regenerations at low temperature with the minimal or no heat input.
- Short adsorption/regeneration cycles reduce bed size and weight.

R&D challenges

- Assuring consistency in sorbent material and minimizing batch-to-batch variation for large scale manufacture.
- Reducing the use of purge gas during regeneration.
- Confirming resistance to syngas contaminants.

results to date/accomplishments

- Completed sorbent optimization.
 - Identified an optimum chemical composition.
 - Production scaleup.
- Achieved high CO₂ capacity in bench-scale experiments.
- Saturation capacity approaching 20 wt% CO₂.
 - 6–8 wt% working capacity.
 - Long-term durability through 11,650 cycles.
- Fabricated a skid-mounted, four-bed, high-temperature PSA system and successfully carried out sorbent evaluation with syngas from an air-blown gasifier at NCCC (Wilsonville, AL) and an O₂-blown gasifier at Wabash River IGCC power plant (Terra Haute, IN).
 - Sorbent maintained its performance over 1,030 adsorption/regeneration cycles at NCCC and over 715 cycles at Wabash River IGCC power plant (the same sorbent was used in the two evaluations).
 - Similar CO₂ capacity was observed before, during, and after testing of the sorbent (altogether, 26,750 standard cubic feet [scf] of syngas has been treated), suggesting minimal impact of syngas impurities due to high-temperature operation.
- System simulation studies carried out in collaboration with UCI, indicate that TDA's CO₂ technology (warm gas CO₂ capture) will provide higher net plant efficiency and lower levelized cost-of-electricity (COE) than an IGCC plant equipped with Selexol (cold gas capture).
 - TDA's warm gas capture technology achieves a net plant efficiency of 34 percent compared to 31.6 percent for Selexol scrubbing technology
 - Water consumption is also lower, providing a water savings of 8.5 kmol per MWh.
 - Levelized COE, including transportation, storage, and monitoring (TS&M) costs for CO₂, is calculated as \$92.90/MWh for TDA's warm gas capture technology compared to \$105.20/MWh for Selexol scrubbing technology.
- Completed initial techno-economic analysis.
- Refined the 2-D computational fluid dynamics (CFD) model of vessel undergoing a complete CO₂ sorption/desorption cycle and completed 3-D CFD model for the 8-bed pilot unit.
- Developed a sorbent manufacturing plan and quality assurance plan.
- Preliminary design of the 0.1MWe pilot unit has been developed, with the system containing a Gas Conditioning Unit to adjust purity and concentration of the synthesis gas, and a high-temperature pressure swing adsorption based CO₂ separation unit.

next steps

- Continue development of adsorption model to calculate concentration distribution across the sorbent bed for specified reactor design and cycle configuration.
- Utilize model to identify impact of design properties on key process parameters.
- Design and fabrication of pilot unit.
- Produce quantity of sorbent needed for two field tests in pilot unit.

available reports/technical papers/presentations

Alptekin, G., et. al. “A Low Cost, High Capacity Regenerable Sorbent for Pre-Combustion CO₂ Capture,” Final Report, September 30, 2012. <http://www.osti.gov/scitech/biblio/1082143>.

“Pilot Testing of a Highly Efficient Pre-Combustion Sorbent-Based Carbon Capture System,” presented by Gökhan Alptekin, TDA Research Inc., 2014 NETL CO₂ Capture Technology Meeting, Pittsburgh, PA, July 2014. [http://www.netl.doe.gov/File Library/Events/2014/2014 NETL CO₂ Capture/G-Alptekin-TDA-Pre-Combustion-Sorbent-Based-Capture.pdf](http://www.netl.doe.gov/File%20Library/Events/2014/2014%20NETL%20CO2%20Capture/G-Alptekin-TDA-Pre-Combustion-Sorbent-Based-Capture.pdf).

Pilot Testing of a Highly Efficient Pre-Combustion Sorbent-Based Carbon Capture System,” Project Kick-Off Meeting, January 2013. [http://www.netl.doe.gov/File Library/Research/Coal/carbon capture/pre-combustion/FE0013105-Kickoff-Pilot-Testing-PreCombustion-CO₂Capture-2014-01-16.pdf](http://www.netl.doe.gov/File%20Library/Research/Coal/carbon%20capture/pre-combustion/FE0013105-Kickoff-Pilot-Testing-PreCombustion-CO2Capture-2014-01-16.pdf).

Alptekin, G., Jayaraman, A., and Copeland, R., “Low Cost, High Capacity Regenerable Sorbent for Precombustion CO₂ Capture,” presented at the 2012 NETL CO₂ Capture Technology Meeting, Pittsburgh, PA, July 2012.

Alptekin, G., “A Low Cost, High Capacity Regenerable Sorbent for CO₂ Capture,” presented at the International Colloquium on Environmentally Preferred Advanced Power Generation (ICEPAG), Costa Mesa, CA, February 2012. [http://www.netl.doe.gov/File%20Library/Events/2012/CO₂%20Capture%20Meeting/G-Alptekin-TDA-Research-Pre-combustion-Sorbent.pdf](http://www.netl.doe.gov/File%20Library/Events/2012/CO2%20Capture%20Meeting/G-Alptekin-TDA-Research-Pre-combustion-Sorbent.pdf).

Alptekin, G., Jayaraman, A., Dietz, S., and Schaefer, M., “High Capacity Regenerable Sorbent for Pre-Combustion CO₂ Capture,” presented at the 28th Annual International Pittsburgh Coal Conference (IPCC), Pittsburgh, PA, September 2011.

Alptekin, G., Jayaraman, A., and Copeland, R., “Low Cost, High Capacity Regenerable Sorbent for Pre-Combustion CO₂ Capture,” presented at the 2011 NETL CO₂ Capture Technology Meeting, Pittsburgh, PA, August 22–26, 2011.

EVALUATION OF DRY SORBENT TECHNOLOGY FOR PRE-COMBUSTION CO₂ CAPTURE

primary project goals

URS Group and the University of Illinois at Urbana-Champaign (UIUC) are developing dry carbon dioxide (CO₂) sorbent materials, through the coupling of thermodynamic, molecular simulation, as well as process simulation modeling with novel synthesis methods, that possess superior adsorption and regeneration properties at conditions applicable to water gas shift (WGS) systems. If successful, this project will demonstrate that one or more sorbent materials are able to remove greater than 90 percent of the CO₂ from a simulated synthesis gas (syngas) at conditions applicable to a WGS reactor, thus meeting a key U.S. Department of Energy (DOE) program objective.

technical goals

Specific technical objectives of this project include:

- Determination of optimal CO₂ sorbent properties and operating conditions for CO₂ removal and regeneration and carbon monoxide conversion in a simulated syngas using a combination of computational and experimental methods.
- Development of one or more sorbents that recover high-quality heat during CO₂ adsorption, regenerate at elevated pressure, have minimal deactivation over multiple cycles, have high selectivity at high temperatures, have high adsorption capacity, and have acceptable thermal stability and mechanical integrity. This will result in sorbents capable of 90 percent CO₂ removal with high loading capacities and able to operate at the high temperatures and pressures typically encountered upstream of a WGS reactor. If successful, the sorbents developed in this program will augment or replace the carbon monoxide conversion catalysts currently used in WGS reactors and improve overall WGS thermal efficiency.
- Determine the techno-economic feasibility of the sorption-enhanced WGS (SEWGS) process for removing CO₂.

technical content

URS Group is leading development of a dry sorbent process configured to combine the WGS reaction with CO₂ removal for coal gasification systems. The result will be an SEWGS technology.

A novel approach integrates the use of multiple computational models with sorbent synthesis and characterization activities to develop sorbents with optimal CO₂ removal properties at high temperatures and pressures applicable to WGS applications. Tests evaluate sorbent performance in simulated WGS gas mixtures at commercially relevant conditions. Appropriate data reduction and analysis provides suitable data for a techno-economic analysis to evaluate the feasibility and scaleup potential of the SEWGS technology.

technology maturity:

Bench-Scale Using Simulated Syngas

project focus:

Sorbent Development for WGS

participant:

URS Group, Inc.

project number:

FE-0000465

NETL project manager:

Elaine Everitt
elaine.everitt@netl.doe.gov

principal investigator:

Carl Richardson
URS Group, Inc.
carl.richardson@urs.com

partners:

Illinois Clean Coal Institute
University of Illinois at Urbana-Champaign

performance period:

1/1/10 – 9/30/13

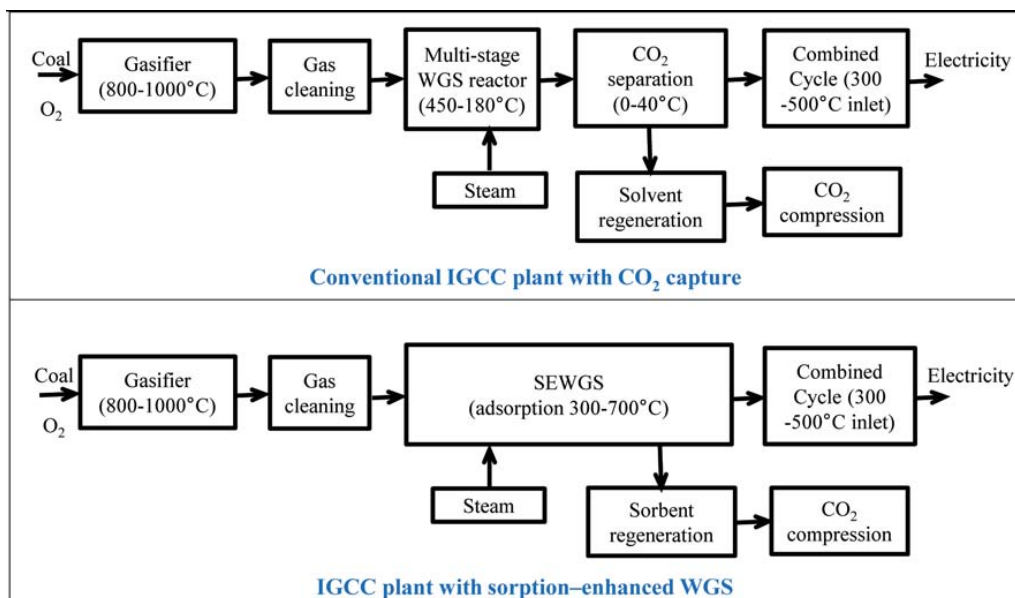

Figure 1: IGCC with SEWGS vs. Conventional IGCC

Process simulation modeling and sorbent molecular and thermodynamic analyses by UIUC allow prediction of optimal sorbent properties and identification of optimal operating temperature and pressure windows to maximize the energy efficiency of the combined WGS and CO₂ capture processes. The thermodynamic study includes developing phase equilibrium diagrams for potential sorbents, identifying optimum operating conditions for CO₂ capture, understanding impacts of syngas impurities, and identifying promising sorbents. Molecular simulation predicts isotherms and properties, kinetics, and dynamics, and identifies sorbents with desired properties using quantum chemistry/mechanics, force field-based molecular dynamics (MD), and reactive dynamics (RD) simulations. Process simulation analyzes various process scenarios for heat integration between SEWGS and integrated gasification combined cycle (IGCC) and process energy performance for individual sorbents.

The first phase testing and modeling efforts guide the synthesis of sorbents with desired pore structure and composition. Synthesis includes use of various precursors, including calcium, magnesium, and other metal oxides, as well as zirconates, titanates, silicates, aluminates, and adsorbent-shift catalyst hybrid. The sorbent down-selection process is guided by the decision tree shown in Figure 2.

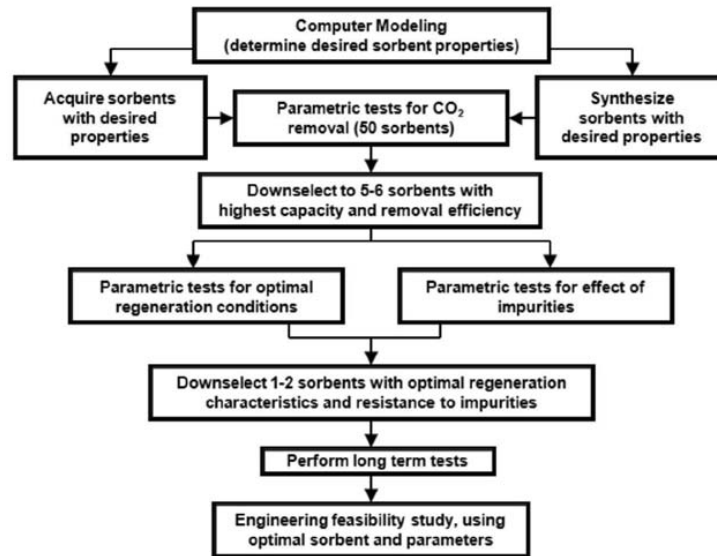

Figure 2: Sorbent Development and Analysis Decision Tree

An atmospheric-pressure thermogravimetric analyzer (TGA) and high temperature and pressure reactor (HTPR) system, capable of 300 pounds per square inch gauge (psig) and 950 °C, are UIUC’s primary tools for screening sorbents for CO₂ removal. A URS HTPR provides the capability to evaluate five to seven down-selected sorbents’ adsorption performance in the presence of syngas impurities and regeneration performance. Long-term testing is limited to a down-selection of one to two sorbents.

A preliminary engineering study of process feasibility for adsorbing and removing CO₂ as part of the WGS process, and comparison to base WGS operation and other CO₂ removal strategies, is informed by the preceding laboratory test results. Parameters under evaluation include costs of >90 percent removal (cost of electricity [COE], operation and maintenance [O&M]), sorbent costs, anticipated lifetime (i.e., replacement rate), estimated future market costs of precursor materials, handling equipment, sorbent regeneration costs, heat/energy integration, compression costs with SEWGS, unit footprint, and capital costs and scalability.

TABLE 1: SOLID SORBENT PARAMETERS

	Units	Current R&D Value	Target R&D Value
Sorbent			
True Density at STP	kg/m ³		TBD
Bulk Density	kg/m ³		TBD
Average Particle Diameter	mm	nano (20–70 nm) or micro meter (0.5–10 μm) level; particles can be pelletized if needed	TBD based on the reactor design analysis
Particle Void Fraction	m ³ /m ³		
Packing Density	m ² /m ³		
Solid Heat Capacity at STP	kJ/kg-K	<1	<1
Crush Strength	kgf		
Manufacturing Cost for Solvent	\$/kg		
Absorption			
Pressure	bar	30–40	40
Temperature	°C	300–700	550–650
Equilibrium CO ₂ Loading	g mol CO ₂ /kg		
Heat of Absorption	kJ/mol CO ₂	100–200	TBD

Desorption			
Pressure	bar	up to 30	highest possible up to 30
Temperature	°C	depends on individual sorbent and highest regeneration pressure achievable	TBD; optimization based on minimal energy limit
Equilibrium CO ₂ Loading	mol/mol		
Heat of Desorption	kJ/mol CO ₂		
Proposed Module Design		<i>(for equipment developers)</i>	
Flow Arrangement/Operation	—	temperature swing	temperature swing
Flue Gas Flowrate	kg/hr		
CO ₂ Recovery, Purity, and Pressure	%/%/bar	90 percent, 99 percent	
Adsorber Pressure Drop	bar	depending on sorbent properties, to be determined during project	TBD

Definitions:

STP – Standard Temperature and Pressure (15 °C, 1 atm).

Sorbent – Adsorbate-free (i.e., CO₂-free) and dry material as used in adsorption/desorption cycle.

Manufacturing Cost for Sorbent – “Current” is market price of material, if applicable; “Target” is estimated manufacturing cost for new materials, or the estimated cost of bulk manufacturing for existing materials.

Adsorption – The conditions of interest for adsorption are those that prevail at maximum sorbent loading, which typically occurs at the bottom of the adsorption column. These may be assumed to be 1 atm total flue-gas pressure (corresponding to a CO₂ partial pressure of 0.13 bar) and 40 °C; however, measured data at other conditions are preferable to estimated data.

Desorption – The conditions of interest for desorption are those that prevail at minimum sorbent loading, which typically occurs at the bottom of the desorption column. Operating pressure and temperature for the desorber/stripper are process-dependent. Measured data at other conditions are preferable to estimated data.

Pressure – The pressure of CO₂ in equilibrium with the sorbent. If the vapor phase is pure CO₂, this is the total pressure; if it is a mixture of gases, this is the partial pressure of CO₂. Note that for a typical PC power plant, the total pressure of the flue gas is about 1 atm and the concentration of CO₂ is about 13.2 percent. Therefore, the partial pressure of CO₂ is roughly 0.132 atm or 0.130 bar.

Packing Density – Ratio of the active sorbent area to the bulk sorbent volume.

Loading – The basis for CO₂ loadings is mass of dry, adsorbate-free sorbent.

Flow Arrangement/Operation – Gas-solid module designs include fixed, fluidized, and moving bed, which result in either continuous, cyclic, or semi-regenerative operation.

Estimated Cost – Basis is kg/hr of CO₂ in CO₂-rich product gas; assuming targets are met.

This is a research and development (R&D) program involving fairly immature technology. As such, many target R&D values will be determined during execution of the test program and will be impacted by a number of key process parameters, including sorbent type and cost, sorbent performance and loading capacity, sorbent lifetime, regeneration conditions and cycling parameters, and complexity of integration of optimal adsorption and regeneration processing steps.

Sorbent Heating/Cooling Method – For sorbent regeneration, the sorbent is heated in a fluidized-bed or moving-bed configuration with heat supplied by either hydrogen (H₂) (or syngas) oxy-combustion or steam extracted from the gasification plant steam cycle. Before entering the adsorption bed, the regenerated sorbent is cooled by exchanging heat with inlet regeneration H₂/oxygen (O₂) or syngas. In the adsorption bed, a heat exchanger (such as a boiler tube bundle used in the fluidized-bed boiler) is used for recovering heat generated from CO₂ adsorption.

Heat of Adsorption Handling – Adsorption heat is recovered during CO₂ adsorption by using a heat exchanger to generate steam, which is combined into the gasification plant's steam cycle for electricity generation.

Heat Supply Method for Regeneration – Two methods are considered. One is to burn a small amount of the H₂ or syngas using O₂ to supply heat directly. Another approach is to use the steam from the gasification plant's steam cycle if the regeneration temperature is below 1,000 °F.

Contamination Resistance – This program will evaluate the impact of various syngas impurities on the adsorption and regeneration performance of promising CO₂ sorbents. Sorbents may not be resistant to sulfur species (hydrogen sulfide [H₂S], carbon disulfide [CS₂], etc).

Syngas Pretreatment Requirements – The pretreatment of H₂S/CS₂ is needed for sorbents with no sulfur resistance. If it is determined that the performance of identified sorbents is inhibited by sulfur species present in the syngas, additional work will focus on the development of sorbents materials that are resistant to sulfur; the objective will be to avoid the need for syngas pretreatment associated with this technology.

Waste Streams Generated – Desulfurization byproducts.

technology advantages

- High carbon monoxide conversion with reduced stream addition.
- No or limited WGS catalyst use.
- High-quality adsorption heat usable for generation of high-quality steam.
- Limited gas cooling/reheating requirement downstream.
- No separate CO₂ capture unit required.
- Reduced energy requirement for CO₂ compression.

R&D challenges

- Sorbent pores may be plugged during adsorption, causing capacity and activity loss.
- Long-term capacity and activity stability after multiple cycles.
- Selectivity at high temperature.
- System/reactor issues, such as material transport and handling at high temperature and pressure.

results to date/accomplishments

- More than 40 sorbents were modeled and subsequently down-selected to seven candidates (magnesium oxide [MgO], calcium oxide [CaO], lithium zirconate [Li₂ZrO₃], calcium zirconium oxide [CaZrO₃], barium zirconate [BaZrO₃], barium titanate [BaTiO₃], and barium silicate [BaSiO₃]) for further development.
- Process simulations were performed for a baseline IGCC plant with WGS and a Selexol process and compared to an IGCC with SEWGS. These showed a 0.5–2.4 percentage point increase in net thermal efficiency for the simulated plant with SEWGS.
- Molecular simulation studies included quantum chemical (QC) calculations and MD simulations with reactive field force (ReaxFF). Molecular simulation was successfully applied to assess carbonation and calcination reactions (CaO).
- The impacts of sorbent structure and the sintering of calcium oxide particles with and without CO₂ chemisorption, and the role of a dopant in reducing the sintering of CaO particles, were also determined.
- More than 60 SEWGS sorbents were synthesized using mechanical alloying (MA), ultrasonic spray pyrolysis (USP), and flame spray pyrolysis (FSP) techniques.
- CaO sorbents prepared by dry and wet ball-milled MA methods exhibited improved CO₂ adsorption capacities and stabilities over commercial CaCO₃ materials. The performance of CaCO₃ sorbents was improved by doping with inert MgO.
- Hollow, porous CaCO₃ sorbents synthesized using the USP method were spheres of ≈1 μm with a shell thickness of 50–100 nm. The CaO generated upon calcination of the CaCO₃ exhibited a high surface area (up to 75 m²/g).

- A 75:25 w/w CaO:Ca₁₂Al₁₄O₃₃ (mayenite) sorbent retained 91 percent of its initial CO₂ capacity after 15 cycles and 79 percent after 50 cycles, while a USP CaO only retained 43 percent after 15 cycles.
- The surface area of nano-sized (<70 nm) CaO, ZrO₂-doped CaO, MgO, MgO-doped CaO, and ZrO₂-doped MgO sorbents synthesized using the FSP method ranged between 21 and 54 m²/g. ZrO₂ was found to be an effective dopant to improve the stability of CaO-based sorbents. A ZrO₂-CaO (Zr:Ca=0.2:1) sorbent maintained its capacity at 0.5 g CO₂/g sorbent over 15 adsorption-desorption cycles.
- An HTPR tube reactor with quarter-inch ID and 1-foot length was also used to test sorbents at UIUC. These tests were performed at 650 °C and CO₂ partial pressures up to 4 bar adsorption conditions.
- Results from the HTPR testing showed sorbents with as high as 0.4 grams of CO₂ per grams of sorbent capacity with the ability to initially shift the WGS completely toward CO₂/H₂.
- A longer term experiment with a simple syngas matrix and N₂/steam regeneration stream showed a USP sorbent (#199) to be stable through 50 adsorption-regeneration cycles, though the sorbent tested had a somewhat diminished initial capacity.

next steps

This project ended on September 30, 2013.

available reports/technical papers/presentations

Richardson, Carl, URS Group et al., “Evaluation of Dry Sorbent Injection Technology for Pre-Combustion CO₂ Capture,” Final Report, 2013. <http://www.osti.gov/scitech/biblio/1136521>.

“Evaluation of Dry Sorbent Technology for Pre-Combustion CO₂ Capture,” Carl Richardson, URS Corporation, 2013 NETL CO₂ Capture Technology Meeting, Pittsburgh, PA, July 2013. <http://www.netl.doe.gov/File%20Library/Events/2013/CO2%20Capture/C-Richardson-URS-Dry-Sorbent-Technology.pdf>.

Hong Lu, Yongqi Lu, Massoud Rostam-Abadi, “CO₂ Sorbents for a Sorption-Enhanced Water-Gas-Shift Process in IGCC plants: A Thermodynamic Analysis and Process Simulation Study,” International Journal of Hydrogen Energy, Volume 38, Issue 16, 30 May 2013, Pages 6663-6672. <http://www.sciencedirect.com/science/article/pii/S0360319913006770>.

Steen, W.; Richardson, C.; Machalek, T.; Paradis, J.; Rostam-Abadi, M.; Lu, Y.; Lu, H.; Napoli, M.; and Everitt, E., “Solid Sorbent-Enhanced Water-Gas Shift Process for Pre-Combustion CO₂ Capture,” Proceedings of the Power Plant Air Pollutant Control “Mega” Symposium, Paper #16, Baltimore, MD, August 2012.

Evaluation of Dry Sorbent Technology for Pre-Combustion CO₂ Capture; Presentation at the 2012 NETL CO₂ Capture Technology Meeting, Pittsburgh, PA, July 2012. <http://www.netl.doe.gov/publications/proceedings/12/CO2capture/presentations/4-Thursday/B%20Steen-URS-Pre-combustion%20Sorbent.pdf>.

Lu, Y.; Lu, H.; Rostam-Abadi, M.; Sayyah, M.; Suslick, K.; Steen, W.; Richardson, C.; Hirschi, J.; and Napoli, M., “Evaluation of Dry Sorbent Technology for Pre-Combustion CO₂ Capture,” Proceedings of the Clearwater Clean Coal Conference—37th International Technical Conference on Clean Coal and Fuel Systems, Clearwater, FL, June 2012.

Steen, W.; Richardson, C.; Lu, Y.; Lu, H.; and Rostam-Abadi, M., “Evaluation of Dry Sorbent Technology for Pre-Combustion CO₂ Capture,” Proceedings of the 2011 DOE-NETL CO₂ Capture Technology Meeting, Pittsburgh, PA, August 2011. <http://www.netl.doe.gov/publications/proceedings/11/CO2capture/presentations/4-Thursday/25Aug11-Steen-URS-Dry%20Sorbent%20Pre-CombustionCapture.pdf>.

Richardson, C., and Lu, Y., “Evaluation of Dry Sorbent Technology,” Presentation at the 2010 NETL CO₂ Capture Technology Meeting, Pittsburgh, PA, September 2010. <http://www.netl.doe.gov/publications/proceedings/10/CO2capture/presentations/thursday/Carl%20Richardson%20-%20FE0000465.pdf>.

“Evaluation of Dry Sorbent Technology for Pre-Combustion CO₂ Capture,” Pre-Combustion CO₂ Capture Kick-Off Meetings, Pittsburgh, PA, November 2009. <http://www.netl.doe.gov/publications/proceedings/09/CO2capture/7-URS%20Dry%20Sorbent%20Kickoff%20Presentatin-111309.pdf>.

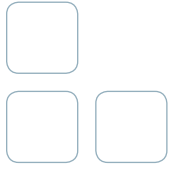

PRE-COMBUSTION MEMBRANE TECHNOLOGIES



DEVELOPMENT OF A PRE-COMBUSTION CO₂ CAPTURE PROCESS USING HIGH-TEMPERATURE PBI HOLLOW-FIBER MEMBRANES

primary project goals

SRI is developing, at a bench-scale size, a technically and economically viable CO₂ capture system based on a high-temperature polybenzimidazole (PBI) polymer membrane separation system and optimizing the process for integration of that system into an integrated gasification combined cycle (IGCC) plant.

technical goals

- Collect laboratory data for separating hydrogen from simulated synthesis gas using PBI-based membrane modules at temperatures and pressures relevant for a pre-combustion CO₂ capture technology.
- Fabricate membrane modules of sufficient capacity to process a syngas stream (50-kWth equivalent of a shifted gas from an oxygen-blown gasifier) using equipment of industrial relevance.
- Produce design and steady-state performance data for membrane modules using syngas (pre-combustion fuel gas) from an operating coal gasifier through bench-scale testing. Testing is to be at a field test site (e.g., the National Carbon Capture Center [NCCC]) at temperatures ≈ 225 °C and up to a pressure of 30 bar under various operating conditions, including long-term steady-state conditions.
- Transfer the membrane fabrication technology to an industrial firm that specializes in the manufacture of hollow fiber membrane for making membrane modules.

technical content

SRI is developing a bench-scale system to advance their PBI membrane-based CO₂ capture system previously researched under DOE-funded project FC26-07NT43090. The membrane is used for high temperature pre-combustion separation of H₂ from shifted syngas, leaving a high concentration, high pressure CO₂-rich stream in the retentate. SRI's membranes are asymmetric hollow-fiber PBI, which is chemically and thermally stable at temperatures up to 450 °C and pressures up to 55 atm (800 psig). This characteristic permits the use of PBI membrane for CO₂ capture downstream of a water gas shift (WGS) reactor, without requiring further gas cooling before the PBI membrane, significantly increasing plant efficiency. In addition, the CO₂ is recovered at high pressure, decreasing CO₂ compression requirements.

PBI-based hollow fibers, as seen in magnified view in Figure 1, offer a considerable advantage over stainless steel-coated tubes. They require as much as 24 times less membrane surface area and 305 times less membrane volume when using a 0.1–0.5 micrometer separation layer (the dense layer). Figure 2 represents a batch of hollow fiber prepared at SRI. Figure 3 shows the prototype membrane test system at SRI.

technology maturity:

Laboratory-Scale Using Simulated Syngas;
Bench-Scale Using Actual Syngas

project focus:

PBI Polymer Membrane

participant:

SRI International

project number:

FE0012965

NETL project manager:

Elaine Everitt
elaine.everitt@netl.doe.gov

principal investigator:

Indira Jayaweera
SRI
indira.jayaweera@sri.com

partners:

Enerfex, Inc.
Electric Power Research Institute
PBI Performance Products
Generon, IGS Energy
Commercialization, LLC

performance period:

10/01/13 – 10/31/16

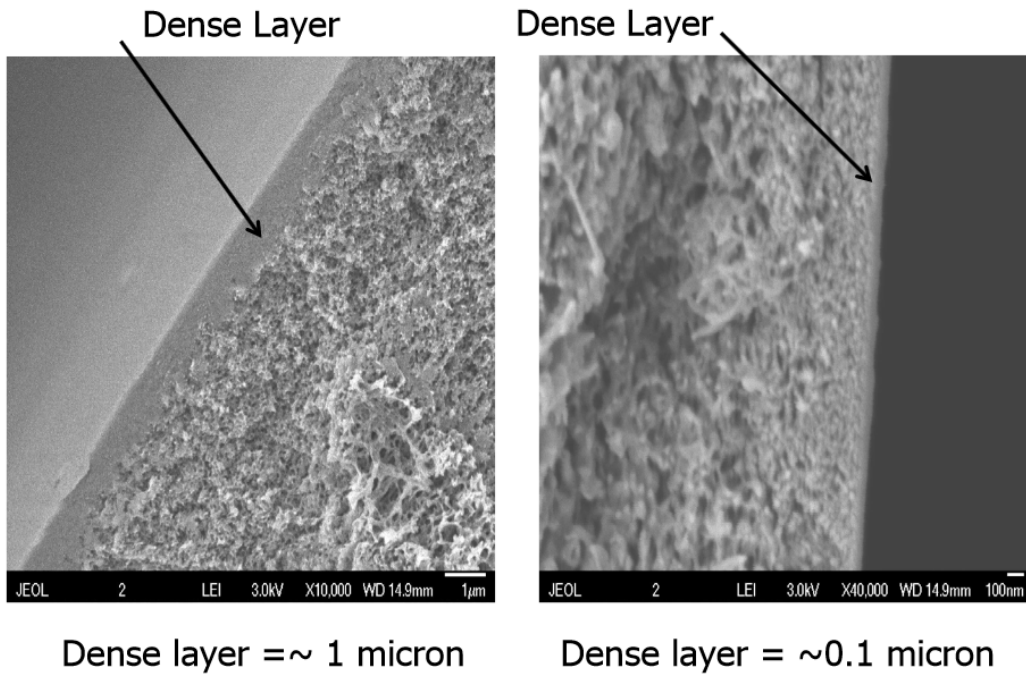

Figure 1: Cross-Section of PBI Hollow Fiber Membrane with Dense Outer and Porous Inner Layers

The durability of narrow, single-bore, PBI-based hollow fibers has been shown to be considerable, with near-constant levels of permeability and selectivity over the course of 330 days while in the presence of hydrogen (H₂), carbon monoxide (CO), methane (CH₄), nitrogen (N₂), CO₂, and hydrogen sulfide (H₂S) at 250 °C.



Figure 2: Photographs of Bundles of PBI Asymmetric Hollow Fibers as Spun (left) and Post Treated (right)



Feed gas:
 H_2 , CO , CO_2 and CH_4

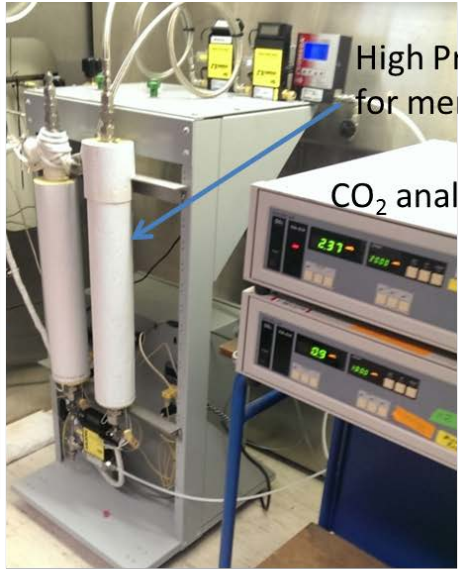

High Pressure vessels
for membrane elements

CO_2 analyzers

Figure 3. Photograph of the Prototype Membrane Test System at SRI

TABLE 1: SRI MEMBRANE PARAMETERS

	Units	Current R&D Value	Target R&D Value
Materials Properties			
Materials of Fabrication for Selective Layer	—	PBI	PBI
Materials of Fabrication for Support Layer	—	PBI	PBI
Nominal Thickness of Selective Layer	μm	0.3–2	<0.5
Membrane Geometry	—	Hollow fiber	Hollow fiber
Max Trans-Membrane Pressure	bar	≈14	>27
Hours Tested Without Significant Degradation	—		
Manufacturing Cost for Membrane Material	\$/m ²	30–80	TBD
Membrane Performance			
Temperature	°C	200–250	225
H ₂ Pressure Normalized Flux	GPU or equivalent	80–120	>120
H ₂ /H ₂ O Selectivity	—	<1	<1
H ₂ /H ₂ S Selectivity (Dense layer thickness)	—	>200 (>1 μm)	>200 (<0.3 μm)
H ₂ /CO ₂ Selectivity (Dense layer thickness)	—	40 (> 1 μm) and 22 (<0.3 μm)	40 (<0.3 μm)
H ₂ /N ₂ Selectivity (Dense layer thickness)	—	98 (>1 μm)	98 (< 0.3 μm)
H ₂ /CO Selectivity (Dense layer thickness)	—	101 (>1 μm)	101 (<0.3 μm)
Sulfur Tolerance	ppm	TBD	TBD
Type of Measurement	—	pure and mixed	mixed gases
Proposed Module Design		<i>(for equipment developers)</i>	
Flow Arrangement	—	counter current	
Packing Density	m ² /m ³	>3,000	
Shell-Side Fluid	—	retentate or permeate	
Flue Gas Flowrate	kg/hr	22	
CO ₂ Recovery, Purity, and Pressure	%/%/bar	TBD	
H ₂ Recovery, Purity, and Pressure	%/%/bar	85–90%, 95%, 30 bar	
Pressure Drops Shell/Tube Side*	psi	<0.1/0.4	

*Generon 4-inch module design with 200 μm bore diameter and 400–700 psia feed pressure was assumed.

Definitions:

Membrane Geometry – Flat discs or sheets, hollow fibers, tubes, etc.

Pressure Normalized Flux – For materials that display a linear dependence of flux on partial pressure differential, this is equivalent to the membrane's permeance.

GPU – Gas Permeation Unit, which is equivalent to 10⁻⁶ cm³ (1 atm, 0 °C)/cm²/s/cm Hg. For non-linear materials, the dimensional units reported should be based on flux measured in cm³ (1 atm, 0 °C)/cm²/s with pressures measured in cm Hg.

Note: 1 GPU = 3.3464 × 10⁻⁶ kg mol/m²-s-kPa [SI units].

Type of Measurement – Either mixed or pure gas measurements; projected permeance and selectivities should be for mixture of gases found in pre-conditioned syngas.

Flow Arrangement – Typical gas-separation module designs include spiral-wound sheets, hollow-fiber bundles, shell-and-tube, and plate-and-frame, which result in either cocurrent, countercurrent, crossflow arrangements, or some complex combination of these.

Packing Density – Ratio of the active surface area of the membrane to the volume of the module.

Shell-Side Fluid – Either the permeate (H₂-rich) or retentate (syngas) stream.

Other Process Parameters:

Description of Membrane Permeation Mechanism – Molecular sieving and activated diffusion

Contaminant Resistance – PBI is resistant to acidic contaminants

Syngas Pretreatment Requirements – Tar removed

Membrane Replacement Requirements – TBD

Waste Streams Generated – Gaseous waste stream generated includes CO₂ and H₂S separated from the syngas. This stream will be further treated to remove H₂S.

Process Design Concept – Figure 4 shows the block flow diagram for the syngas separation using the PBI membrane system.

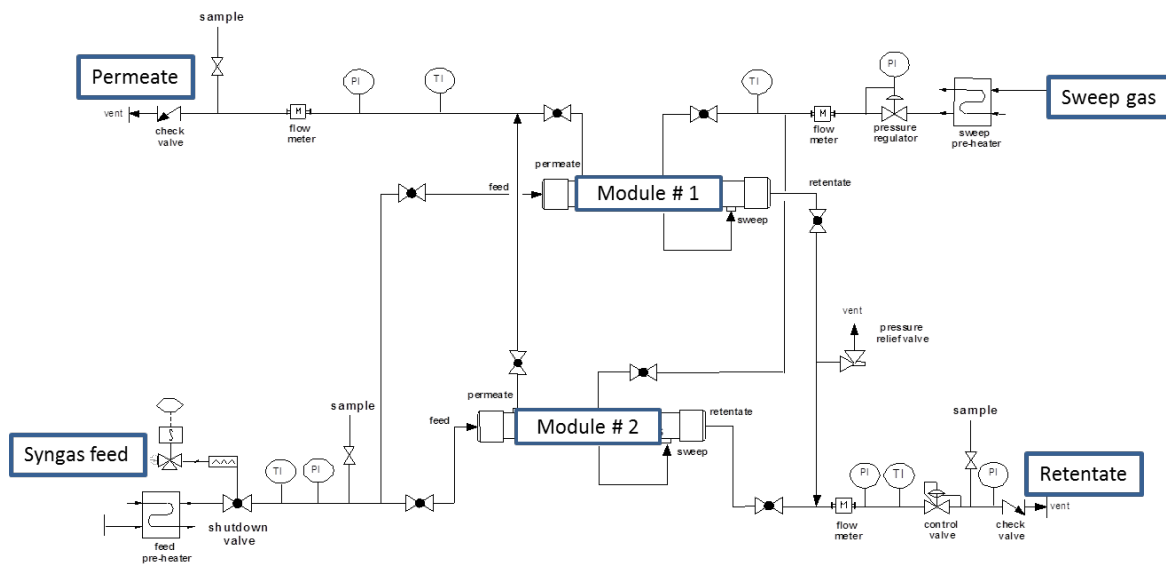

Figure 4. Process Block Diagram for Syngas Separation Using the PBI Membrane System

Proposed Module Design – Module design is tubular with 4-in diameter and 36-in length. Figure 5 shows the simulated module performance, the pressure, temperature and composition of the gas entering the module for field testing at NCCC.

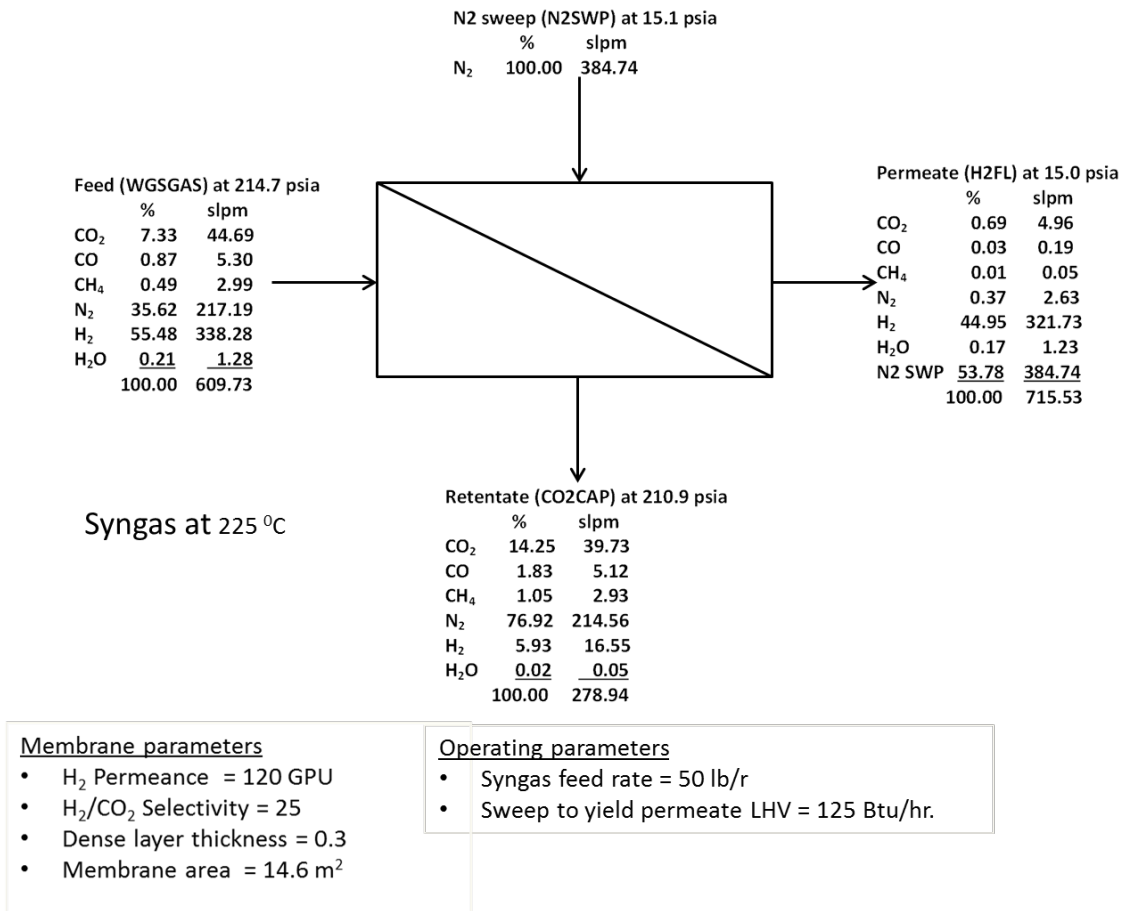

Figure 5. Simulation of the Module Performance Showing the Syngas Composition for 50 lb/hr Testing at NCCC

technology advantages

- PBI combines both useful throughput (permeability) and degree of separation (selectivity).
- PBI is thermally stable up to 450 °C, and sulfur tolerant.
- PBI asymmetric hollow fibers can be fabricated at increasingly small diameters, allowing increased fiber packing densities in modules realistically consistent with 7,000 m² of membrane surface area per m³ of module volume.

R&D challenges

- Maintaining fiber and module fabrication quality/performance (avoiding membrane pinholes, macrovoids; module seal integrity) in scale up/transfer of technology to larger-scale manufacturing.
- Designing and synthesizing materials structure and configurations.
- Integration and optimization of membrane-based CO₂ separation systems in coal gasification-based plants.

results to date/accomplishments

- Performed and analyzed several membrane separation scenarios under various temperatures, pressures, and gases, which showed:
 - PBI membrane-based, high-temperature CO₂ separation is competitive with the Selexol system.
 - Cost-of-electricity (COE) for CO₂ capture may approach the U.S. Department of Energy (DOE) goal under optimized membrane performance.
- Completed characterization using scanning electron microscope (SEM) and X-ray tomography.
- Achieved an H₂ permeability of >80 GPU with an H₂/CO₂ selectivity of 40 at 225 °C
- The hollow fiber module was tested for 120 hours at 225 °C for its H₂ permeation characteristic and H₂/CO₂ selectivity.
- SRI has commissioned the fiber spinning line and prepared new fibers with dense layer thickness range of 0.1–0.3μ.
- 10 km of fibers produced and sent to Generon for assembly into two modules with nominal diameters greater than 1 inch for evaluation using simulated syngas at SRI labs.
- Variation to the coagulation solvent and the fiber annealing process are being investigated, with adjustments to improve the mechanical integrity of spun fibers so they can withstand the rigor of commercial module-making equipment.
- Recently improved fibers were wound on mandrels of increasingly smaller diameters (2.5-inch, 0.75-inch, and 0.25-inch) to evaluate mechanical integrity. The produced hollow fibers were capable of tight winding on a 0.25-inch diameter spool.

next steps

- Accelerated fiber spinning to produce sufficient fiber for the 50-kWth field test.
- Fabricate PBI hollow fiber modules for tests with the bench-scale skid.
- Install a 50-kWth bench-scale membrane skid to accommodate the new membrane modules.
- Conduct field tests using actual syngas.

available reports/technical papers/presentations

“Development of a Pre-Combustion Carbon Dioxide Capture Process Using High Temperature Polybenzimidazole Hollow-Fiber Membrane,” presented by Gopala Krishnan, SRI International, 2014 NETL CO₂ Capture Technology Meeting, Pittsburgh, PA, July 2014. <http://www.netl.doe.gov/File%20Library/Events/2014/2014%20NETL%20CO2%20Capture/G-Krishnan-SRI-PBI-Hollow-Fiber-Membranes.pdf>.

“Development of a Pre-Combustion Carbon Dioxide Capture Process Using High Temperature Polybenzimidazole Hollow-Fiber Membrane Fact Sheet,” July 2014. <http://www.netl.doe.gov/File%20Library/Research/Coal/carbon%20capture/pre-combustion/FE0012965.pdf>.

“Development of a Pre-Combustion CO₂ Capture Process Using High-Temperature PBI Hollow-Fiber Membranes,” Project Kick-Off Meeting Presentation, Pittsburgh, PA, June 9, 2014. <http://www.netl.doe.gov/File%20Library/Research/Coal/carbon%20capture/pre-combustion/DE-FE0012965-Kickoff-Meeting-June-2014.pdf>.

Krishnan, G., “Fabrication and Scale-Up of Polybenzimidazole (PBI) Membrane Based System for Pre-Combustion Based Capture of Carbon Dioxide,” presented at 2011 NETL CO₂ Capture Technology Meeting, Pittsburgh, PA, August 2011. <http://www.netl.doe.gov/publications/proceedings/11/CO2capture/presentations/5-Friday/26Aug11-Krishnan-SRI-PBI%20Membranes%20for%20Pre-Combustion%20Captur.pdf>.

Krishnan, G.; Steele, D.; O'Brien, K.; Callahan, R.; Berchtold, K.; and Figueroa, J., “Simulation of a Process to Capture CO₂ From IGCC Syngas Using a High Temperature PBI Membrane,” *Energy Procedia*, Volume 1, Issue 1, February 2009, pp. 4079-4088.

Gopala Krishnan; Indira Jayaweera; Angel Sanjurjo; Kevin O'Brien; Richard Callahan; Kathryn Berchtold; Daryl-Lynn Roberts; and Will Johnson, “Fabrication and Scale-up of Polybenzimidazole (PBI) Membrane Based System for Precombustion-Based Capture of Carbon Dioxide”, DOE Contract Number: FC26-07NT43090, 2012-March 31. <http://www.osti.gov/scitech/biblio/1050227>

ROBUST AND ENERGY EFFICIENT DUAL-STAGE MEMBRANE-BASED PROCESS FOR ENHANCED CARBON DIOXIDE RECOVERY

primary project goals

Media and Process Technology (MPT) is performing bench-scale testing of a pre-combustion carbon dioxide capture process scheme comprised of (1) hydrogen-selective carbon molecular sieve membranes (CMSM) in a water gas shift membrane reactor (WGS/MR) process that combines the WGS reaction with hydrogen recovery, and (2) palladium (Pd)-based membranes for efficient residual hydrogen recovery from the WGS/MR retentate.

technical goals

- Characterize performance of the technology for hydrogen-carbon dioxide separations from syngas using a laboratory-scale reactor (operating on simulated coal gasification syngas at a rate of approximately 2 standard cubic feet per hour [scfh]).
- Use performance database from lab-scale work as basis to design, construct and shakedown a CMSM-WGS/MR bench-scale unit nominally sized to process approximately 200 scfh of real syngas (i.e., 0.01 MWe) during field-testing.
- Evaluate gas separation efficiency, WGS conversion, and study long-term material stability during bench-scale field testing.
- Perform techno-economic assessment and EH&S analysis for the process.

technical content

The technological approach utilizes supported membranes for H₂-CO₂ gas separations, consisting of a low-cost ceramic substrate/support onto which thin membranes of carbon molecular sieve or palladium may be deposited, as illustrated in Figure 1. The membranes can be created on various ceramic elements, which can be bundled into modules at high packing densities. Use of ceramics permits operation at high temperatures and pressures (up to 350 °C and up to 200 psig) to support warm syngas cleanup regimes.

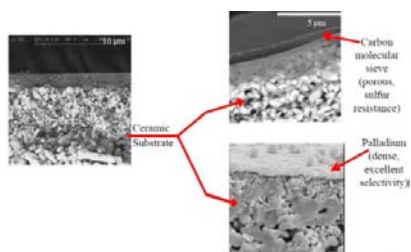

Figure 1: MPT Supported Membranes

technology maturity:

Laboratory-Scale Using Simulated Syngas;
Bench-Scale Using Actual Syngas

project focus:

Two-Stage Membrane Separation: Carbon Molecular Sieve Membrane Reactor followed by Pd-Based Membrane

participant:

Media and Process Technology, Inc.

project number:

FE0013064

NETL project manager:

Elaine Everitt
elaine.everitt@netl.doe.gov

principal investigator:

Paul Liu
Media and Process Technology
pliu@mediaandprocess.com

partners:

Technip USA Corporation
University of Southern California

performance period:

10/01/2013 – 9/30/2016

MPT's chosen process arrangement is illustrated in Figure 2. This is a two-stage process, in which the first stage consists of a WGS reactor incorporating the CMSM. The CMSM was developed initially in previously funded DOE project FC26-07NT43057. Hydrogen-rich permeate is separated in this stage via the CMSM, which efficiently drives the WGS reaction to higher levels of hydrogen conversion. The retentate from the first stage retains most of the acid gases (and essentially all of the sulfur content) plus a significant residual fraction of hydrogen; these gases are processed in conventional cold gas cleanup steps to recover the sulfur. The cleaned retentate then enters a second-stage membrane separator consisting of supported Pd membrane modules. Pure CO₂ permeate is separated in this stage, suitable for sequestration, and hydrogen-rich retentate gases can be blended with permeate from the first stage for use such as fuel gas in a combustion turbine for power generation. Other uses of the gas are possible, such as additional purification to produce pure hydrogen.

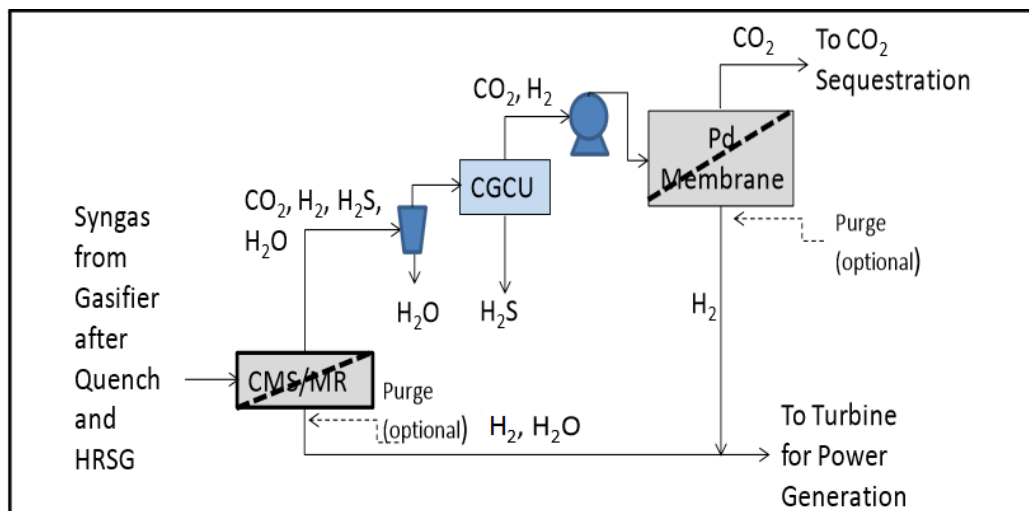

Figure 2: MPT Process Configuration with Dual Membrane Stages

technology advantages

- The process arrangement avoids significant capital and compression costs associated with conventional two-stage operation, largely by operating the initial stage at pressure as delivered from the gasifier and upstream from the gas cleanup, and with the benefit of removing a significant amount of hydrogen-rich gas prior to cold gas cleanup, significantly reducing the required size and cost of the cold gas cleanup unit.
- Limiting its use to an ancillary secondary stage in the form of a supported thin film reduces demand for Pd metal significantly over CO₂ separation schemes that would rely solely on Pd membrane use, thereby addressing both issues of the very high cost and limited availability of Pd metal.

R&D challenges

- Optimize pore size tuning: pore size tuning needs improvement to maximize H₂ permeance with the rejection of H₂S.
- Improve WGS reactor design and catalyst packing.
- Large surface area of Pd membrane required: minimize membrane area and cost.

results to date/accomplishments

- Completed development of the performance database for both the CMS and Pd-alloy membranes.
- CMS multiple bundle unit demonstrated thermal stability for over 4,500 hours,
- No impact of thermal cycling observed on CMS membrane permeance or selectivity.
- CMS membrane showed over 1,500 hours of hydrothermal stability.

- Pd-Ag membrane has shown thermal stability in presence of hydrogen for 7,000 hours.
- Prepared highly permeable Pd-alloy membranes that satisfy performance and stability requirements for proposed subsystem to recover H₂ from high pressure CO₂ stream.
- Preliminary simulations of various process configurations were completed.
 - A first stage membrane separator is required to remove H₂ from the raw gasifier off-gas, promoting CO conversion in the downstream reactors, via either true membrane reactors or a series of membrane separators plus packed bed reactors. Without the membrane separator as a stand-alone first unit operation, it is not possible to achieve CO conversions above approximately 75–80 percent.
 - Following the first membrane separator, both “true membrane reactors” and membrane separator plus packed bed reactors showed CO conversions >95 percent.

next steps

- Extreme pressure testing of membrane and module components.
- Multiple bundle unit will be modified to include the catalyst as a membrane reactor for water gas shift reaction. CMS WGS-MR field testing at the National Carbon Capture Center (NCCC).
- Engineering design and analysis of overall process scheme.

available reports/technical papers/presentations

“Robust and Energy Efficient Dual-Stage Membrane-Based Process for Enhanced CO₂ Recovery,” presented by Richard Ciora, Media and Process Technology, Inc., 2014 NETL CO₂ Capture Technology Meeting, Pittsburgh, PA, July 2014.

[http://www.netl.doe.gov/File%20Library/Events/2014/2014%20NETL%20CO₂%20Capture/R-Ciora-MPT-Enhanced-CO₂-Recovery.pdf](http://www.netl.doe.gov/File%20Library/Events/2014/2014%20NETL%20CO2%20Capture/R-Ciora-MPT-Enhanced-CO2-Recovery.pdf).

“Robust and Energy Efficient Dual-Stage Membrane-Based Process for Enhanced CO₂ Capture Fact Sheet,”

<http://www.netl.doe.gov/File%20Library/Research/Coal/carbon%20capture/pre-combustion/FE0013064.pdf>.

“Robust and Energy Efficient Dual-Stage Membrane-Based Process for Enhanced CO₂ Capture,” Project Kick-Off Meeting Presentation, [http://www.netl.doe.gov/File%20Library/Research/Coal/ewr/CO₂/DE-FE0013064-Kick-Off-Meeting.pdf](http://www.netl.doe.gov/File%20Library/Research/Coal/ewr/CO2/DE-FE0013064-Kick-Off-Meeting.pdf).

Abdollahi, M., et al., “Hydrogen Production from Syngas, Using a Catalytic Membrane Reactor,” presented at the North American Membrane Society, Charleston, SC, June 2009.

Abdollahi, M., et al., “Integrated One-Box Process for Hydrogen Production From Syngas,” presented at the 2009 Annual Meeting, American Institute of Chemical Engineers (AIChE), November 2009.

POLYMER-BASED CARBON DIOXIDE CAPTURE MEMBRANE SYSTEMS

primary project goals

Los Alamos National Laboratory (LANL) is developing and demonstrating polymer-based membrane structures, deployment platforms, and sealing technologies that achieve the critical combination of high selectivity, high permeability, chemical stability, and mechanical stability at elevated temperatures (>150 °C) and packaged in a scalable, economically viable, high area density system amenable to incorporation into an integrated gasification combined cycle (IGCC) plant for pre-combustion carbon dioxide (CO₂) capture.

technical goals

- Continue to develop and demonstrate high-temperature, polybenzimidazole (PBI)-based membrane chemistries and morphologies for carbon capture and hydrogen purification from coal-derived shifted synthesis gas (syngas).
 - Operation under industrially relevant process conditions.
 - Stability in the presence of anticipated concentrations of primary syngas components and impurities.
- Develop the fabrication materials and methods required to realize those materials and morphologies as defect-free, high-area density hollow fiber membranes (HFMs) and modules.
- Demonstrate the technology potential via materials and membrane performance evaluation under industrially relevant process conditions.
 - Conduct permselectivity and materials stability evaluations under realistic syngas conditions.
 - Reduce perceived technical risks of utilizing a polymeric membrane-based technology in a challenging (thermal, chemical, mechanical) syngas environment.

technical content

LANL work, from a previously funded project FWP-10-002, demonstrated that PBI and other benzimidazole-based materials show promise as membranes for pre-combustion-based capture of CO₂. The primary goals of this project are to: continue to develop and demonstrate PBI-based materials and morphologies as a separation media for hydrogen purification and carbon capture; demonstrate the performance of those materials in industrially relevant process streams; and further develop fabrication methodologies and separation schemes to support the technically and economically viable integration of a pre-combustion CO₂ capture system based on these materials into an advanced IGCC plant. The ultimate achievement in the area of CO₂ capture is the production of a CO₂-rich stream at pressure using methods compatible with the overall U.S. Department of Energy/National Energy Technology Laboratory (DOE/NETL) Carbon Capture program research goals. The work that this project team is pursuing is aligned directly with these capture goals and utilizes a pre-combustion capture approach focused on the continued development of high-temperature, polymer-based membranes that will ultimately be integrated into an advanced IGCC process.

technology maturity:

Bench-Scale Using Simulated Syngas

project focus:

High-Temperature Polymer-Based Membrane

participant:

Los Alamos National Laboratory

project number:

FWP-308-13, FWP-10-002, 04FE13-AC24

NETL project manager:

Elaine Everitt
elaine.everitt@netl.doe.gov

principal investigator:

Kathryn A. Berchtold
Los Alamos National Laboratory
berchtold@lanl.gov

partners:

PBI Performance Products
NETL

performance period:

10/1/08 – 3/31/16

A PBI-based membrane selective layer chemistry is being utilized by the LANL project team. PBI is a unique polymer family that is stable to temperatures approaching 500 °C. PBI possesses excellent chemical resistance, a high glass transition temperature (>430 °C), good mechanical properties, and an appropriate level of processability. The PBI-based membranes developed by this project team have demonstrated operating temperatures significantly higher than 150 °C (up to 450 °C) with excellent chemical, mechanical, and hydrothermal stability. The materials and membranes that have been developed and continue to be optimized as part of this project outperform any polymer-based membrane available commercially or reported in the literature for separations involving hydrogen. This achievement is validated via membrane productivity (separation factor and flux) comparisons (Figure 1). The improved performance of this technology in an application such as IGCC-integrated capture is further substantiated by the accessible operating temperature range (up to 400 °C), long-term hydrothermal stability, sulfur tolerance, and overall durability of the proposed membrane materials in these challenging pre-combustion environments. These characteristics have been validated via extensive evaluations of LANL's polymer-based membrane in simulated syngas environments containing hydrogen (H₂), CO₂, methane (CH₄), nitrogen (N₂), carbon monoxide (CO), steam (H₂O), and hydrogen sulfide (H₂S), from 25 to 400 °C, and demonstration of the membrane's thermal stability via 300-plus days in operation at 250 °C. These achievements and material/membrane property validations were largely conducted on flat sheet and tubular platform membranes prior to this project effort.

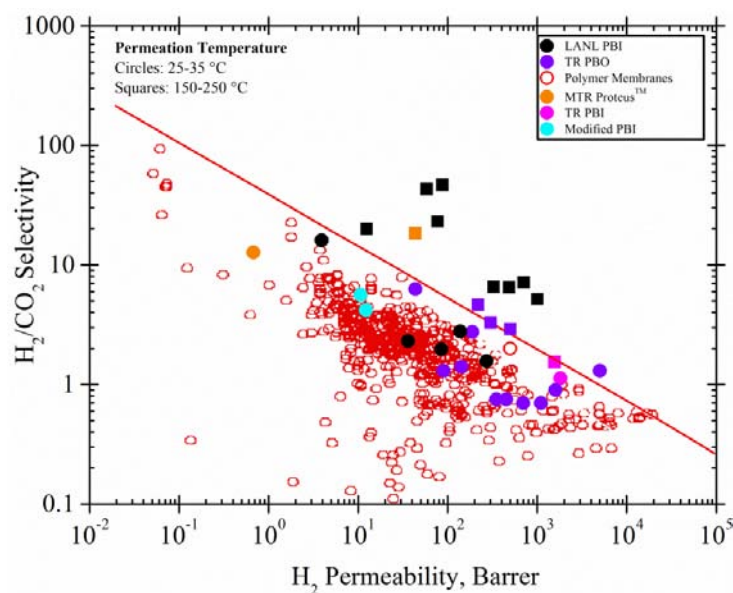

Figure 1: Robeson Plot Comparing PBI Composite Membrane with Other Polymeric Membranes Tested for H₂/CO₂ Separation

The line represents the 2008 upper bound and Red symbols are the corresponding experimental data from Robeson JMS 320 (2008) 390-400. Data taken from LANL PBI: Berchtold *et al.* JMS 415 (2012) 265-270, Xin *et al.* JMS 461 (2014) 59-68 & Pesiri *et al.* JMS 218 (2003) 11-18; Modified PBI: Kumbharkar *et al.* JMS 286 (2006) 161-169; Membrane Technology & Research (MTR) Proteus: Merkel *et al.* JMS 389 (2012) 441-450; Thermally Rearranged Polybenzoxazole (TR PBO): Han *et al.* PCCP 14 (2012) 4365-4373 & Park *et al.* JMS 359 (2010) 11-24; TR-PBI: Hans *et al.* JMS 357 (2010) 143-151.

These previous programmatic efforts were focused on the utilization of the PBI formulations as a selective layer deposited on and supported by a unique porous metal substrate (fabricated by Pall Corporation). Systems, economic, and commercialization analyses conducted by NETL, LANL, and others, combined with in- and out-of-laboratory testing, established the technical viability of the technology and indicated the strong potential for the membrane-based capture technology to meet and exceed the DOE Carbon Capture program goals. However, these analyses also made clear the need to cut the costs of the support material and increase the area density realized by the ultimate module design in order to realize the desired step-change in both performance and cost of CO₂ capture associated with the use of this membrane-based capture technology. One promising option for achieving a substantial increase in active membrane area density and mitigating the cost of a metal or inorganic material-based support is the use of a HFM platform. A HFM is the membrane configuration with the highest achievable packing density (i.e., the highest membrane selective area density). Commercial HFM modules have been fabricated to obtain selective area densities as high as 30,000 m²/m³. This affords the opportunity to achieve several orders of magnitude improvement over the density achievable with the previous polymeric-metallic membrane platform (ca. 250 m²/m³). Realization of such an increase in area density with the materials previously developed by this team will lead to substantial economic and technical benefits.

The work being conducted as part of this continuing development and demonstration effort includes the advancement of these materials in a commercially viable, all polymeric, HFM platform (Figure 2). HFMs provide numerous opportunities for realization of the desired performance and economic enhancements associated with the use of this membrane-based capture technology for pre-combustion capture. Hollow fibers represent a high area density membrane platform, which will reduce the size requirement of the costly, high-temperature-tolerant membrane module housings, will minimize membrane support costs through their all-polymeric design, and will facilitate membrane flux maximization through processing facilitated selective layer thickness minimization. LANL will explore the synergies that derive from combining these advantageous hollow fiber characteristics to produce a high-flux, high area density membrane platform that meets or exceeds DOE system performance and economic goals.

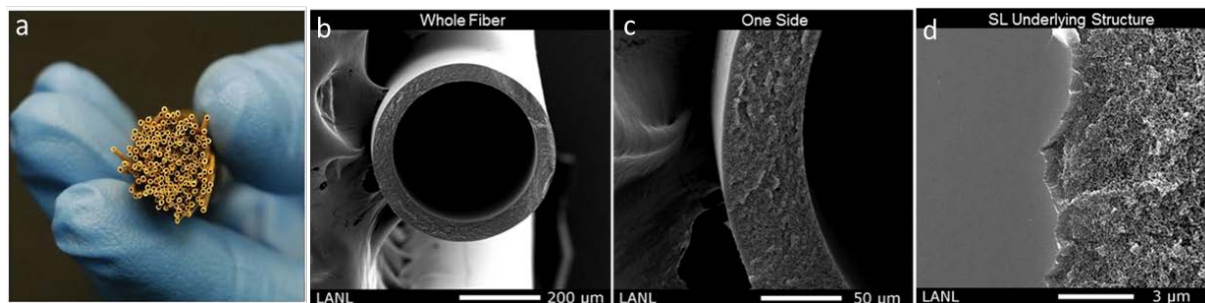

Figure 2: (a) On-End Image of Small PBI Hollow Fiber Bundle Prepared at LANL; (b-d) Illustrative SEM images of PBI hollow fiber membrane prepared by LANL. (b) whole fiber cross-section; (c) one side cross-section; and (d) outer selective layer and underlying support structure.

Current and future work is aimed at translation of the previously developed membrane materials chemistries into a high area density HFM platform via commercially viable HFM manufacturing methods, developing and deploying defect-mitigation strategies for optimizing membrane performance and durability, and demonstrating the produced membranes in simulated and ultimately real process environments with the overarching goal of technology progression toward commercialization.

TABLE 1: MEMBRANE PROCESS PARAMETERS

	Units	Current R&D Value		Target R&D Value
Materials Properties				
Materials of Fabrication for Selective Layer		high T _g polymer		
Materials of Fabrication for Support Layer		metallic composite	high T _g polymer	high T _g polymer
Nominal Thickness of Selective Layer	μm	0.6	0.2–0.5	0.1–0.5
Membrane Geometry		tubular	hollow fiber	hollow fiber
Maximum Trans-Membrane Pressure	bar	30 ¹	12.5 ¹	30
Hours Tested Without Significant Degradation		8,400 (at 250 °C) ²	3,000 (at ≥250 °C) ²	1,000
Manufacturing Cost for Membrane Material	\$/m ²	>100		15
Membrane Performance				
Temperature	°C	250	150–350	150–350
H ₂ Pressure Normalized Flux	GPU or equivalent	170	200–275	250
H ₂ /H ₂ O Selectivity	—	≈1	≈0.3	
H ₂ /CO ₂ Selectivity	—	42	25	25–40
H ₂ /H ₂ S Selectivity	—	>1,800	ND ³	>1,800
Sulfur Tolerance	ppm	10,000	100 ⁴	1,000
Type of Measurement	—	mixed and pure	mixed ⁵ and pure	mixed
Proposed Module Design				
Flow Arrangement	—	counter	counter/complex	
Packing Density	m ² /m ³	250	2,000–15,000	
Shell-Side Fluid	—	retentate		

TABLE 1: MEMBRANE PROCESS PARAMETERS

	Units	Current R&D Value	Target R&D Value
Syngas Gas Flowrate	kg/hr	210–240	
CO ₂ Recovery, Purity, and Pressure	%/%/bar	75-90% ⁷ , HPD ^{6,7} , 50 bar ⁷	
H ₂ Recovery, Purity, and Pressure	%/%/bar	80-99% ^{7,8} , HPD ^{6,8} , 20 bar ⁸	
Pressure Drops Shell/Tube Side	bar	not yet defined ⁹	

¹ Max TMP tested, not max achievable TMP.
² No degradation observed during testing.
³ H₂S non-detectable in permeate stream using current on-line analytics.
⁴ Max sulfur content tested with current generation HFMs, not sulfur tolerance.
⁵ Typical Mixed gas conditions: simulated syngas 50.3% H₂, 19.2% H₂O, 29.4% CO₂, 1.1% CO with 0, 20, & 100 ppm H₂S.
⁶ Highly process dependent (HPD).
⁷ Gasifier, coal feedstock, upstream unit operation (e.g., water-gas shift [WGS]), and downstream unit operation (e.g., CO₂ purification) specifications dependent.
⁸ Tailored to match the turbine inlet specifications (e.g., 125 LHV Btu/ft³ and 20 bar permeate).
⁹ Optimized HFM geometry, module geometry, and all module design components are not fully defined.

Definitions:

Membrane Geometry – Flat discs or sheets, hollow fibers, tubes, etc.

Pressure Normalized Flux – For materials that display a linear dependence of flux on partial pressure differential, this is equivalent to the membrane's permeance.

GPU – Gas Permeation Unit, which is equivalent to 10⁻⁶ cm³ (1 atm, 0 °C)/cm²/s/cm Hg. For non-linear materials, the dimensional units reported should be based on flux measured in cm³ (1 atm, 0 °C)/cm²/s with pressures measured in cm Hg.

Note: 1 GPU = 3.3464 × 10⁻⁶ kg mol/m²-s-kPa [SI units].

Type of Measurement – Either mixed or pure gas measurements; projected permeance and selectivities should be for mixture of gases found in pre-conditioned syngas.

Flow Arrangement – Typical gas-separation module designs include spiral-wound sheets, hollow-fiber bundles, shell-and-tube, and plate-and-frame, which result in either cocurrent, countercurrent, crossflow arrangements, or some complex combination of these.

Packing Density – Ratio of the active surface area of the membrane to the volume of the module.

Shell-Side Fluid – Either the permeate (H₂-rich) or retentate (syngas) stream.

Other Parameter Descriptions:

Membrane Permeation Mechanism – Solution diffusion where at the proposed elevated separation temperatures, permeability is dominated by gas diffusivity in the selective layer.

Contaminant Resistance – Excellent resistance to syngas contaminants.

Syngas Pretreatment Requirements – Particulate removal.

Process Design Concept – Multiple location possibilities largely influenced by gasifier type (syngas pressure and quality), the employed WGS technology, and the presence or lack thereof of a warm temperature gas cleanup for sulfur removal prior to the capture step. For performance benchmark purposes, the membrane separation is conducted post-low temperature (250 °C) WGS. Nitrogen from the air separation unit (ASU) is used as a membrane sweep gas, with the sweep flows specified based on the turbine inlet heating value specification. Initial evaluations have utilized GE F-class turbine specifications and GE (Texaco) gasifier-radiant operation.

Proposed Module Design – Hollow fiber module design comprised of high-pressure, high-temperature housings and components. The syngas will be processed at process temperature and pressure. The conditions of the primary separation position will be matched to those at the exit of the low-temperature WGS reactor. The pressure drop utilized will be tailored based on the turbine inlet pressure. This process favors conditions created by gasifiers that operate at higher pressure.

technology advantages

- Broad accessible membrane operating temperature range (150–350 °C) facilitating increased opportunity for process integration/optimization.
- Demonstrated long-term hydrothermal stability, sulfur tolerance, and overall durability of selective layer materials.
- Membrane-based technology competitive advantages: modularity, low-maintenance operations, small footprint, low/no waste process, and flexible design opportunities.
- CO₂ produced at higher pressure enables reduced compression costs.

R&D challenges

- Design, control, prediction, and synthesis of tailored material morphologies in hollow fiber format.
- Realizing high-permeance, defect-free gas separation viable hollow fibers.
- Realizing sealing materials and methods compatible with the target material and process thermal, chemical, and mechanical characteristics/environments.

results to date/accomplishments

- Translation to robust, high-permeance, hollow fiber-based module platform achieved, optimization on-going.
 - Fundamental understanding of multi-component phase inversion system developed.
 - Translation of those learnings into fiber fabrication protocols established.
 - Control of selective layer thickness and mechanically robust support structure morphology demonstrated using processing and phase inversion manipulations.
 - Solvent/non-solvent systems leading to reduced HFM manufacturing costs developed.
 - Membranes that retain selectivity over the broad temperature range of 150–350 °C developed.
- Successful demonstration of HFMs with permselectivity characteristics matching that of the shell-and-tube composite membranes.
- Module fabrication materials and methods developed, enabling high temperature HFM evaluation.
- Methods for defect healing and sealing developed and demonstrated.
 - Performance of membrane prototypes incorporating healing and sealing approaches indicate exceptional opportunities for defect mitigation with minimal transport resistance using developed methods.
 - Sealing layer efficacy and composite structure tolerance to sulfur containing syngas operating environments (150–350 °C) demonstrated.
- High performance PBI hollow fiber membranes with high H₂ permeance (≥250 GPU) and H₂/CO₂ selectivity (≥25) developed and demonstrated.
 - No reduction in H₂ permselectivity performance demonstrated for PBI hollow fiber membrane at 250 °C for approximately 3,000 hours in simulated syngas.
- Long term evaluations of HFMs in simulated syngas with and without H₂S indicate exceptional tolerance to carbon, steam, and sulfur at process temperatures, and that H₂ permeance and selectivity unaffected by CO and H₂S.
- Collaboration with NETL to apply NETL Computational Fluid Dynamic (CFD) expertise to R&D module design and assessment initiated.
 - Effort goal: to advance and accelerate the realization of multi-fiber HFM modules with hydrodynamic and mass transfer considerations utilized to maximize and accurately predict membrane performance in module format.
 - CFD model construction, validation with simulated syngas test data, and optimization ongoing.
- Patent to protect IP filed. Continued IP protection on-going. Interactions with industry regarding tech-transfer and commercialization opportunities on-going.

next steps

- Continued development and demonstration of HFM fabrication methodologies to achieve high-permeance membranes in defect-minimized platforms.
- Further minimization of selective layer thickness—permselectivity optimization.
- Optimization of HFM geometry.
- Further development, demonstration, and implementation of fiber healing and sealing materials and methods.
- Demonstration of multi-fiber module performance correlated with predicted performance from CFD studies (with NETL).
- Continued/Enhanced industry engagement to progress Technology Readiness Level (TRL) and commercialization opportunities.
- Module demonstration using actual coal-derived IGCC syngas.

available reports/technical papers/presentations

High-Temperature Polymer Based Membrane Systems for Pre-Combustion Carbon Dioxide Capture [PDF] (July 2014) Presented by Kathryn A. Berchtold, Los Alamos National Laboratory, 2014 NETL CO₂ Capture Technology Meeting, Pittsburgh, PA.
<http://www.netl.doe.gov/File%20Library/Events/2014/2014%20NETL%20CO2%20Capture/K-Berchtold-LANL-Pre-Combustion-CO2-Capture.pdf>

Singh, R. P., Dahe, G. J., Dudeck, K. W., Welch, C. F., and Berchtold, K. A., “High Temperature Polybenzimidazole Hollow Fiber Membranes for Hydrogen Separation and Carbon Dioxide Capture from Synthesis Gas” *Energy Procedia* **63** (2014)153-9.

High-Temperature Polymer Based Membrane Systems for Pre-Combustion Carbon Dioxide Capture [PDF] (July 2013) Presented by Kathryn A. Berchtold, Los Alamos National Laboratory, 2013 NETL CO₂ Capture Technology Meeting, Pittsburgh, PA.
<http://www.netl.doe.gov/File%20Library/Research/Coal/carbon%20capture/pre-combustion/K-Berchtold-LANL-High-Temperature-Polymer-based-Membrane-Sys.pdf>

Berchtold, K.A.; Singh, R.P.; Young, J.S.; and Dudeck, K.W., “Polybenzimidazole Composite Membranes for High Temperature Synthesis Gas Separations,” *Journal of Membrane Science* **415-416** (2012) 265-70.

Han, S.H., and Kwon, H.J., et al., “Tuning Microcavities in Thermally Rearranged Polymer Membranes for CO₂ Capture,” *Physical Chemistry Chemical Physics* **14** (2012) 4365-73.

Stauffer, P.; Keating, G.; Middleton, R.; Viswanathan, H.; Berchtold, K.A.; Singh, R.P.; Pawar, R.; and Mancino, A., “Greening Coal: Breakthroughs and Challenges in Carbon Capture and Storage,” *Environmental Science & Technology* **45** (2011) 8597-604.

Krishnan, G.D.; Steele, D.; O’Brien, K.C.; Callahan, R.; Berchtold, K.A.; and Figueroa, J.D., “Simulation of a Process to Capture CO₂ from IGCC Syngas Using a High-Temperature PBI Membrane,” *Energy Procedia* **1** (2009) 4079-88.

O’Brien, K.C.; Krishnan, G.; Berchtold, K.A.; and Figueroa, J.D., et al., “Toward a Pilot-Scale Membrane System for Pre-Combustion CO₂ Separation,” *Energy Procedia* **1** (2009) 287-94.

PRE-COMBUSTION CARBON DIOXIDE CAPTURE BY A NEW DUAL-PHASE CERAMIC-CARBONATE MEMBRANE REACTOR

primary project goals

Arizona State University is developing a dual-phase, membrane-based separation device that will separate carbon dioxide (CO₂) from typical water-gas shift (WGS) mixture feeds and produce hydrogen (H₂), which can be introduced into the combustion turbines of integrated gasification combined cycle (IGCC) plants.

technical goals

- Synthesize chemically and thermally stable dual-phase, ceramic-carbonate membranes with CO₂ selectivity (with respect to [H₂], carbon monoxide [CO], or water [H₂O]) larger than 500 and CO₂ permeance larger than 5×10^{-7} mol/m²/s/Pa.
- Fabricate tubular dual-phase membranes and membrane reactor modules suitable for WGS membrane reactor applications.
- Identify experimental conditions for WGS in the dual-phase membrane reactor that will produce the hydrogen stream with at least 93 percent purity and the CO₂ stream with at least 95 percent purity.

technical content

A membrane separation device consisting of a porous metal phase and a molten carbonate phase can conduct carbonate ions (CO₃²⁻) at a high rate. The metal-carbonate membranes only conduct electrons implying oxygen (O₂) should be mixed with CO₂ in the feed in order to convert CO₂ to CO₃⁻ ions. However, the presence of O₂ can also oxidize the metallic support and reduce its electronic conductivity, and thus CO₂ permeability. The problem is addressed by the proposed dual-phase, ceramic-carbonate membrane configuration consisting of a porous ionic conducting ceramic phase and a molten carbonate phase.

At the upstream surface, CO₂ reacts with oxygen ions supplied from the ceramic phase to form CO₃⁻, which transports through the molten carbonate phase towards the downstream surface of the membrane. On the downstream surface, the reverse surface reaction takes place, converting CO₃⁻ to CO₂, with O⁻ released and transported back through the ceramic phase towards the upstream surface of the membrane. The net effect is permeation of neutral CO₂ through the membrane driven by the CO₂ pressure gradient. The dual-phase membrane will be made of continuous thin mesoporous oxygen ionic-conducting ceramic layer filled with a molten carbonate, supported on porous stainless steel or other metal, with an intermediate layer of sub-micron, pore-sized oxygen ionic conducting material.

technology maturity:

Lab-Scale Using
Simulated Syngas

project focus:

Dual-Phase Ceramic-
Carbonate Membrane
Reactor

participant:

Arizona State University

project number:

FE0000470

NETL project manager:

Elaine Everitt
elaine.everitt@netl.doe.gov

principal investigator:

Jerry Y.S. Lin
Arizona State University
jerry.lin@asu.edu

partners:

None

performance period:

10/1/09 – 9/30/14

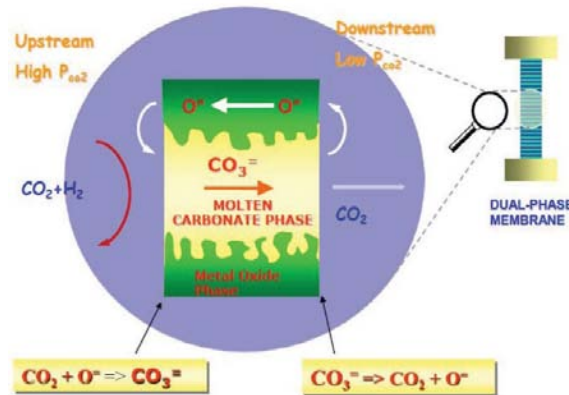

Figure 1: Concept of Dual-Phase Membrane

Development of this dual-phase membrane will be divided in to two phases. Phase I work will include identifying optimum conditions for synthesis of adequate membrane supports and the dual-phase membranes in disk geometry and studying gas permeation properties of the membranes. The second part of the Phase I work will be focused on fabrication of the dual-phase membranes in tubular geometries and the study of permeation, chemical, and mechanical stability of the tubular membranes relevant to their uses in membrane reactors for WGS reaction.

Phase II work will be directed towards studying the dual-phase membrane reactor performance for WGS reaction for hydrogen production and CO₂ capture. The work includes synthesis and kinetic study of a high-temperature WGS catalyst and experimental and modeling study of WGS reaction on the dual-phase membrane reactors. The experimental data will be compared with modeling results to identify optimum operating conditions for WGS reaction. The project will perform an economic analysis using the dual-phase membrane as a WGS reactor for hydrogen production and CO₂ capture for an IGGC plant.

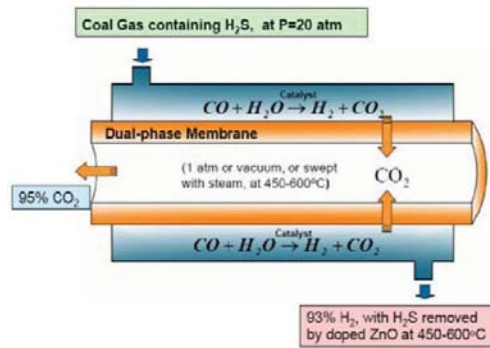

Figure 2: Proposed Membrane Reactor for WGS Reaction

TABLE 1: MEMBRANE-BASED CO₂ SEPARATIONS

	Units	Current R&D Value	Target R&D Value
Materials Properties			
Materials of Fabrication for Selective Layer	—	Li ₂ /K ₂ CO ₃	doped Li ₂ /K ₂ CO ₃
Materials of Fabrication for Support Layer	—	porous stainless steel	fast-ionic conductors (doped ZrO ₂ , CeO ₂)
Nominal Thickness of Selective Layer	μm	2,000	10-200
Membrane Geometry	—	disk	tube
Max Trans-Membrane Pressure	bar	2	>6
Hours Tested Without Significant Degradation	—	N/A	>700
Manufacturing Cost for Membrane Material	\$/m ²	/	500
Membrane Performance			
Temperature	°C	700–900	700–900
CO ₂ Pressure Normalized Flux	GPU or equivalent	600	>1,000
CO ₂ /H ₂ O Selectivity	—	300	>500
CO ₂ /H ₂ Selectivity	—	300	>500
CO ₂ /SO ₂ Selectivity	—	—	>500
Type of Measurement	—		
Proposed Module Design		<i>(for equipment developers)</i>	
Flow Arrangement	—	flat disk	Tube – counter-flow
Packing Density	m ² /m ³	10	>60
Shell-Side Fluid	—		steam
Syngas Flowrate	L(STP)/min (per tube)		>0.2
CO ₂ Recovery, Purity, and Pressure	%/%/bar		90%/99.5%/1 atm
H ₂ Recovery, Purity, and Pressure	%/%/bar		99.9%/93%/>6 atm
Pressure Drops Shell/Tube Side	bar		>6

Definitions:

Membrane Geometry – Flat discs or sheets, hollow fibers, tubes, etc.

Pressure Normalized Flux – For materials that display a linear dependence of flux on partial pressure differential, this is equivalent to the membrane's permeance.

GPU – Gas Permeation Unit, which is equivalent to 10⁻⁶ cm³ (1 atm, 0 °C)/cm²/s/cm Hg. For non-linear materials, the dimensional units reported should be based on flux measured in cm³ (1 atm, 0 °C)/cm²/s with pressures measured in cm Hg.

Note: 1 GPU = 3.3464 × 10⁻⁶ kg mol/m²-s-kPa [SI units].

Type of Measurement – Either mixed or pure gas measurements; projected permeance and selectivities should be for mixture of gases found in pre-conditioned syngas.

Flow Arrangement – Typical gas-separation module designs include spiral-wound sheets, hollow-fiber bundles, shell-and-tube, and plate-and-frame, which result in either cocurrent, countercurrent, crossflow arrangements, or some complex combination of these.

Packing Density – Ratio of the active surface area of the membrane to the volume of the module.

Shell-Side Fluid – Either the permeate (H₂-rich) or retentate (syngas) stream.

Other Parameter Descriptions:

Membrane Permeation Mechanism – Carbon dioxide permeates through by combined transport of carbonate ions in the molten carbonate phase and oxygen ions in the solid metal-oxide phase.

Contaminant Resistance – The membrane to be stable in 0.1–1 percent atmosphere containing hydrogen sulfide (H₂S).

Proposed Module Design – Shell-tube module.

technology advantages

- WGS reaction at one temperature (above 400 °C).
- Separation of CO₂ and H₂ mixture in one step.
- Production of high-pressure hydrogen stream.

R&D challenges

- Failure to obtain sufficiently high CO₂ permeance due to a rate-limiting surface reaction.
- Undesired surface properties of ceramic supports resulting in instability of the carbonate in the support pores.

results to date/accomplishments

- Synthesis of dual-phase membrane disks.
- Tubular membranes were prepared via pressing technique using graphite powders.
- Fabrication techniques of pressing-sintering and centrifugal casting were successfully modified to optimize support micro-structure.
- Thin, dual-phase membranes on porous support of disk and tubular geometries were successfully fabricated.
- High CO₂ selectivity and good CO₂ permeance through the membranes were demonstrated.
- Separation and permeation properties of dual-phase membranes under syngas conditions was modeled and analyzed. CO₂ permeation mechanism and factors affecting CO₂ permeation of the dual-phase membranes have been identified.
- WGS reaction in the dual-phase membrane reactor was studied. Conditions to produce hydrogen of 93 percent purity and CO₂ stream of >95 percent purity, with 90 percent CO₂ capture were identified.

next steps

This project ended on September 30, 2014.

available reports/technical papers/presentations

Lin, Jerry, Final Technical Report, "Pre-Combustion Carbon Dioxide Capture by a New Dual Phase Ceramic-Carbonate Membrane Reactor," <http://www.osti.gov/scitech/biblio/1172599>, publication date September 30, 2014.

Lin, J.Y.S., Final Project Presentation. <http://www.netl.doe.gov/File%20Library/Research/Coal/carbon%20capture/pre-combustion/2014-12-05-Closeout-Presentation-FE0000470.pdf>.

Lin, J.Y.S.; Norton, T.; Ortiz-Landeros, J.; Lu, B.; and Anderson, M; "Pre-Combustion Carbon Dioxide Capture by a New Dual-Phase Ceramic-Carbonate Membrane Reactor," presented at 2014 NETL CO₂ Capture Technology Meeting in Pittsburgh, PA, July 2014. <http://www.netl.doe.gov/File%20Library/Events/2014/2014%20NETL%20CO2%20Capture/X-Dong-ASU-Dual-Phase-Ceramic-Carbonate-Membrane-Reactor.pdf>.

Lin, J.Y.S.; Norton, T.; Dong, X; Lu, B; "Pre-Combustion Carbon Dioxide Capture by a New Dual-Phase Ceramic-Carbonate Membrane Reactor," presented at 2013 NETL CO₂ Capture Technology Meeting in Pittsburgh, PA, July 2013. <http://www.netl.doe.gov/File%20Library/Events/2013/CO2%20Capture/T-Norton-ASU-Dual-Phase-Ceramic-Carbonate-Membrane-Reactor.pdf>.

Lu, B.; and Lin, Y.S., "Sol-Gel Synthesis and Characterization of Mesoporous Yttria Stabilized Zirconia Membranes with Graded Pore Structure," *J. Materials Sci.*, 46, 7056-7066 (2011).

Norton, T.T.; and Lin, Y.S., "Transient Oxygen Permeation and Surface Catalytic Properties of Lanthanum Cobaltite Membrane under Oxygen-Methane Gradient," *Ind. Eng. Chem. Res.*, 51, 12917-12925(2012).

Lin, J.Y.S.; Norton, T.; Ortiz-Landeros, J.; Lu, B.; and Wang, H., "Pre-Combustion Carbon Dioxide Capture by a New Dual-Phase Ceramic-Carbonate Membrane Reactor," presented at 2012 NETL CO₂ Capture Technology Meeting in Pittsburgh, PA, in July 2012.

Rui, Z.B.; Anderson, M.; Li, Y.D.; and Lin, Y.S., "Ionic Conducting Ceramic and Carbonate Dual Phase Membranes for Carbon Dioxide Separation," *J. Membrane Sci.*, 417-418, 174-182 (2012).

Anderson, M.; and Lin, Y.S., "Carbon Dioxide Separation and Dry Reforming of Methane for Synthesis of Syngas by a Dual-Phase Membrane Reactor," *AIChE J.*, 59, 2207-2218 (2013)

Lu, B.; Lin, Y.S., "Synthesis and characterization of thin ceramic-carbonate dual-phase membranes for carbon dioxide separation", *J. Membr. Sci.*, 444, 402-411 (2013)

Dong, X.; Ortiz-Landeros, J.; Lin, Y.S., "An asymmetric tubular ceramic-carbonate dual phase membrane for high temperature CO₂ separation", *Chem. Commun*, 49, 9654-9656 (2013)

Ortiz-Landeros, J., Norton, T.; Lin, Y.S., "Effects of support pore structure on carbon dioxide permeation of ceramic-carbonate dual-phase membranes", *Chem. Eng. Sci.*, 104, 891-898 (2013)

Norton, T.T., Ortiz-Landeros, J., Lin, Y.S., "Stability of La-Sr-Co-Fe oxide-carbonate dual-phase membranes for carbon dioxide separation at high temperatures", *Ind. Eng. Chem. Res.*, 53, 2432-2440 (2014)

Norton, T.T.; Lu, B.; Lin, Y.S., "Carbon dioxide permeation properties and stability of samarium-doped-ceria carbonate dual-phase membranes", *J. Membr. Sci.*, 467, 244-252(2014)

Norton, T.T., Lin, Y.S., "Ceramic-carbonate dual-phase membrane with improved chemical stability for carbon dioxide separation at high temperature", *Solid State Ionics*, 263, 172-179 (2014)

DESIGNING AND VALIDATING TERNARY Pd-ALLOYS FOR OPTIMUM SULFUR/CARBON RESISTANCE

primary project goals

Pall Corporation is developing an economically viable hydrogen (H₂)/carbon dioxide (CO₂) separation membrane system that would allow efficient capture of CO₂ at high temperature and pressure from gasified coal in the presence of typical contaminants using a ternary palladium (Pd)-alloy. Membranes were fabricated and tested in simulated coal gasification conditions. The final objective is a membrane with high hydrogen flux and excellent resistance to syngas contaminants.

technical goals

- Create an advanced Pd-alloy for optimum H₂ separation performance using combinatorial material methods for high-throughput screening, testing, and characterization.
- Demonstrate durability under long-term testing of a pilot membrane in laboratory-scale.
- Understand long-term effects of the coal gasifier environment on the metallurgy of the membrane components by comparing controlled diffusion studies with in-service membranes.

technical content

The project developed an advanced Pd-alloy for optimum H₂ separation performance to demonstrate long-term durability under coal synthesis gas (syngas) conditions. Ternary Pd-alloys with potential for favorable performance were selected based on a literature search. This large set of ternary Pd-alloys underwent combinatorial alloy spreads on thin film support disks. These disks were tested in a syngas environment using in situ Raman spectroscopy to measure H₂ separation factor and permeability, as well as characterize sulfur and carbon resistance of best candidate alloys. These alloys were compared to baseline tests of traditional Pd-gold (Au) alloy membranes.

The best alloys were fabricated into 15-cm² tubular membranes and tested. As with the combinatorial disks, the 15-cm² active area tubes were exposed to conditions representative of a coal gasifier environment: high temperature and high pressure in the presence of contaminating species. Emphasis was placed on identification and characterization of membrane defects, surface analysis of the regions affected by the contaminants, and assessment of the surface quality of the ceramic substrate

technology maturity:

Laboratory-Scale Using
Simulated Syngas

project focus:

Pd-Alloys for
Sulfur/Carbon Resistance

participant:

Pall Corporation

project number:

FE0001181

NETL project manager:

Jason Hissam
jason.hissam@netl.doe.gov

principal investigator:

Scott Hopkins
Pall Corporation
scott_d._hopkins@pall.com

partners:

Cornell University,
Georgia Institute of
Technology,
Colorado School of
Mines,
Southern Company

performance period:

10/1/09 – 9/30/14



Figure 1: A Co-Sputtering Chamber

Scale-up of membranes to 75-cm² was initially planned but was not conducted. The 15-cm² active area tubes were subjected to a 100+ hour continuous testing.

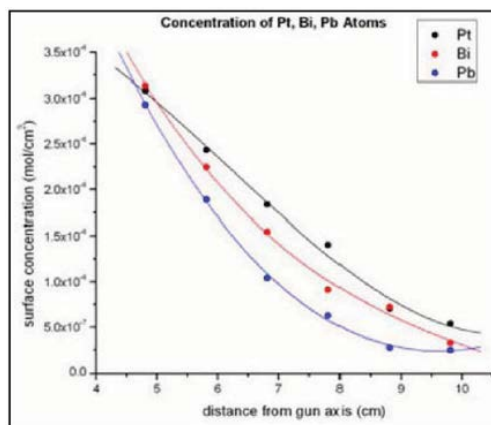

Membrane Figure 2: Graph of Atom Concentration as a Function of Distance from the Gun Axis for Pt, Bi, and Pb Targets



Figure 3: A 75-cm²

Technical Targets:

- Membrane would be tolerant of up to 20 parts per million (ppm) hydrogen sulfide (H₂S).
- Hydrogen flux of 200 ft³/hr/ft² at 400 °C and 20 pounds per square inch (psi) H₂ partial pressure differential.
- Total pressure differential operating capability 400 psi.
- The membrane cost must be in the range of \$500/ft².
- Permeate H₂ purity should be at a level of 99.5 percent.
- The membrane must be resistant to coking with relatively low steam-to-carbon ratio.
- The system should be stable for a minimum of 3 years in service.

TABLE 1: MEMBRANE-BASED CO₂ SEPARATIONS

	Units	Current R&D Value	Target R&D Value
Materials Properties			
Materials of Fabrication for Selective Layer	—	palladium-gold alloys	palladium alloys
Materials of Fabrication for Support Layer	—	zirconia coated porous stainless steel tubes	zirconia coated porous stainless steel tubes
Nominal Thickness of Selective Layer	μm	3–5 μm	3–7 μm
Membrane Geometry	—	shell and tube	shell and tube
Max Trans-Membrane Pressure	bar	400 psi at 400 °C	400 psi at 400 °C
Hours Tested Without Significant Degradation	—	1,000	5,000
Manufacturing Cost for Membrane Material	\$/m ²	1,000	500
Membrane Performance			
Temperature	°C	400	450
H ₂ Pressure Normalized Flux	GPU or equivalent	170	200
H ₂ /H ₂ O Selectivity	—		
H ₂ /CO ₂ Selectivity	—		
H ₂ /SO ₂ Selectivity	—		
Type of Measurement	—		
Proposed Module Design		<i>(for equipment developers)</i>	
Flow Arrangement	—	outside – in	
Packing Density	m ² /m ³		
Shell-Side Fluid	—		
Flue Gas Flowrate	kg/hr		
CO ₂ Recovery, Purity, and Pressure	%/%/bar		
H ₂ Recovery, Purity, and Pressure	%/%/bar		
Pressure Drops Shell/Tube Side	bar		

Definitions:

Membrane Geometry – Flat discs or sheets, hollow fibers, tubes, etc.

Pressure Normalized Flux – For materials that display a linear dependence of flux on partial pressure differential, this is equivalent to the membrane's permeance.

GPU – Gas Permeation Unit, which is equivalent to 10⁻⁶ cm³ (1 atm, 0 °C)/cm²/s/cm Hg. For non-linear materials, the dimensional units reported should be based on flux measured in cm³ (1 atm, 0 °C)/cm²/s with pressures measured in cm Hg.

Note: 1 GPU = 3.3464 × 10⁻⁶ kg mol/m²-s-kPa [SI units].

Type of Measurement – Either mixed or pure gas measurements; projected permeance and selectivities should be for mixture of gases found in pre-conditioned syngas.

Flow Arrangement – Typical gas-separation module designs include spiral-wound sheets, hollow-fiber bundles, shell-and-tube, and plate-and-frame, which result in either cocurrent, countercurrent, crossflow arrangements, or some complex combination of these.

Packing Density – Ratio of the active surface area of the membrane to the volume of the module.

Shell-Side Fluid – Either the permeate (H₂-rich) or retentate (syngas) stream.

Other Parameter Descriptions:

Contaminant Resistance – Palladium-based alloy membranes should tolerate moderate levels of coal gas contaminants after advanced hot syngas cleanup. Primary contaminants include H₂S and carbon monoxide (CO). A typical hot gas cleanup process can bring residual level of sulfur into the range of 0.5–20 parts per million volume (ppmv). After a single-stage water-gas shift (WGS) reactor, CO can be as low as a few percent.

Waste Streams Generated – No waste streams are generated since H₂ is extracted by a Pd-alloy membrane system with primarily CO₂ and water (H₂O) left at high pressure. After steam is condensed, CO₂ is sent for sequestration.

technology advantages

- Researchers use a proprietary process to create ultrathin, economical, Pd-alloy membranes in virtually any alloy system.
- The project applied combinatorial methods to continuous ternary alloy spreads and use a novel characterization method to rapidly scan the alloys after syngas exposure to identify the most resistant compositions.
- A customized composite substrate from Pall was used to deposit ultrathin Pd-alloy membranes. The substrate is porous stainless steel tubes with ceramic coating on the outside surface as a diffusion barrier; thus, membrane elements can be assembled into the module by a conventional welding technique.

R&D challenges

- Hydrogen separation performance may not achieve target performance by membrane design alone. Supplements such as additional gas reforming capabilities may be required either upstream or downstream of the membrane module.
- Scale-up of the Pd-alloy surface area from 15 to 75 cm²; was planned but will not be conducted under this project.
- Membrane durability during thermal cycling and its effect on stability; the stability of the ceramic coated support has been demonstrated, but not the long-term stability with a Pd-alloy membrane in place.

results to date/accomplishments

- Identified six candidate ternary alloys that had little adsorption of sulfur and carbon after exposure.
- Added Colorado School of Mines as a subcontractor to create six ternary alloys for hydrogen permeance testing and sulfur/carbon exposure testing.
- Made 5 cm² membranes for exposure testing.
- Conducted preliminary tests on active area membranes.

next steps

This project ended on September 30, 2014.

available reports/technical papers/presentations

Lewis, A., Hopkins, S.; and H. Zhao “Identifying Pd-Based Ternary Membranes for Carbon and Sulfur Applications,” 2014 NETL CO₂ Capture Technology Meeting, Pittsburgh, PA, July 2014.

[http://www.netl.doe.gov/File%20Library/Events/2014/2014%20NETL%20CO₂%20Capture/A-Lewis-Pall-Pd-Based-Ternary-Membranes.pdf](http://www.netl.doe.gov/File%20Library/Events/2014/2014%20NETL%20CO2%20Capture/A-Lewis-Pall-Pd-Based-Ternary-Membranes.pdf).

Hopkins, S.; and H. Zhao. “High Throughput Design of Ternary Pd Alloys for Optimum Sulfur/Carbon Resistance in Hydrogen Separation and Carbon Capture Membrane Systems,” presented at 2013 NETL CO₂ Capture Technology Meeting in Pittsburgh, PA, July 2013. [http://www.netl.doe.gov/File%20Library/Events/2013/CO₂%20Capture/H-Zhao-Pall-Ternary-Pd-Alloys.pdf](http://www.netl.doe.gov/File%20Library/Events/2013/CO2%20Capture/H-Zhao-Pall-Ternary-Pd-Alloys.pdf).

Hopkins, S.; and H. Zhao. “High Throughput Design of Ternary Pd Alloys for Optimum Sulfur/Carbon Resistance in Hydrogen Separation and Carbon Capture Membrane Systems,” presented at 2012 NETL CO₂ Capture Technology Meeting in Pittsburgh, PA, July 2012.

Hopkins, S. “Designing and Validating Ternary Pd Alloys for Optimum Sulfur/Carbon Resistance,” presented at 2011 NETL CO₂ Capture Technology Meeting in Pittsburgh, PA, August 2011.

Henkel, D., “Combinatorial Design of Pd Ternary Alloys for Sulfur/Carbon Tolerant Hydrogen Separation,” presented at 2010 NETL CO₂ Capture Technology Meeting in Pittsburgh, PA, September 2010.

HYDROGEN-SELECTIVE EXFOLIATED ZEOLITE MEMBRANES

primary project goals

The University of Minnesota researchers are further developing exfoliated zeolite coating technology for hydrogen (H₂) separation membranes, including membrane production methodology, and determining the feasibility of integration of the membrane into a water-gas shift (WGS) reactor model.

technical goals

- Develop and optimize a membrane production method for the exfoliated zeolite coating.
- The membrane must demonstrate high flux, high selectivity, and stable performance.
- Determine the feasibility of integrating these membranes in WGS reactors and integrated gasification combined cycle (IGCC) flow sheets.
- Perform a techno-economic analysis.

technical content

This project will further develop a novel silica molecular sieve membrane using exfoliated zeolite coatings with the potential to contribute to carbon capture by high-temperature separation of H₂ from carbon dioxide (CO₂) and other gases present in shifted synthesis gas (syngas). The project will establish procedures for the production of the required supply of these layered silicates, first optimizing the synthesis process of the exfoliated zeolite, then the layer-by-layer coating process.

The pore structure of the zeolite that is currently studied (MCM-22) includes ultra-small (potentially H₂-selective) sized pores defined by six SiO₄ tetrahedra (6-Member Ring pores: 6MR) along the c-axis. Therefore, c-out-of-plane oriented films are promising for H₂-separation membranes. MCM-22 has highly anisotropic plate or disk-like crystal shape, thin along the c-crystallographic axis and appropriate for achieving c-oriented films. Among available compositions, an all-silica and potentially hydrothermally stable composition has been reported, which could enable H₂-separations in applications like WGS reactors.

Membrane Microstructures Achieved Currently: MCM-22/silica composite films were fabricated using layer-by-layer deposition towards a nanoscale realization of the selective flake concept. The repetition of appropriate deposition cycles (i.e., particle deposition and subsequent silica coating) led to the gradual increase of separation performance achieving H₂/nitrogen (N₂) ideal selectivity as high as 120. The scanning electron microscope (SEM) cross-section image of a five-layer membrane along with its schematic is shown in Figure 1. The aim of the ongoing work is to improve performance using thinner flakes (exfoliated zeolite layers).

technology maturity:

Bench-Scale, Simulated Syngas

project focus:

Hydrogen-Selective Zeolite Membranes

participant:

University of Minnesota

project number:

FE0001322

NETL project manager:

Elaine Everitt
elaine.everitt@netl.doe.gov

principal investigator:

Michael Tsapatsis
University of Minnesota
tsapatsis@umn.edu

partners:

None

performance period:

10/1/09 – 9/30/14

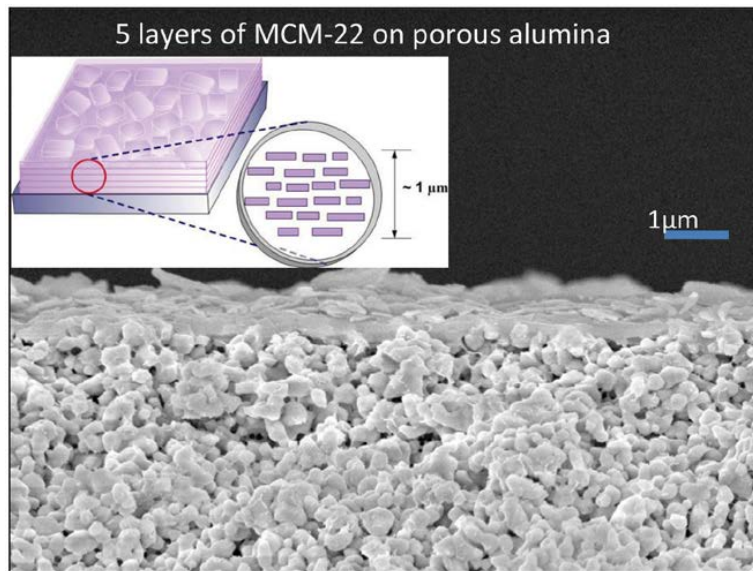

Figure 1: SEM Cross-Section Image of a Five-Layer Membrane Along with Schematic

The H₂ permeance and selectivity to CO₂ and other gases, as well as hydrothermal stability, will be determined for the developed membrane. A series of tests will determine membrane separation performance. Performance testing configurations will include flat alumina supports up to 220 °C; tubular membrane testing using single gases up to 600 °C; tubular membrane testing using simulated feeds up to 600 °C; and high-temperature, high-pressure testing of tubular supports. The membrane stability will be determined in a WGS environment. The three stability test configurations are in steam containing simulated feeds for exfoliated powders; in steam containing simulated feeds for alumina supported films; and in steam containing simulated feeds for stainless steel supported films.

The project will also integrate the membrane into a WGS membrane reactor model, integrate the model in an IGCC flow sheet, and perform techno-economic analysis and operability evaluation and analysis.

TABLE 1: MEMBRANE-BASED CO₂ SEPARATIONS

	Units	Current R&D Value	Target R&D Value
Materials Properties			
Materials of Fabrication for Selective Layer	—	MCM-22 plate like crystals	exfoliated MCM-22 layers
Materials of Fabrication for Support Layer	—	porous alumina discs (homemade)	porous stainless steel tubes (commercial)
Nominal Thickness of Selective Layer	μm		
Membrane Geometry	—		
Max Trans-Membrane Pressure	bar		
Hours Tested Without Significant Degradation	—	48	250
Manufacturing Cost for Membrane Material	\$/m ²		
Membrane Performance			
Temperature	°C	200	500
H ₂ Pressure Normalized Flux	GPU or equivalent		
H ₂ /H ₂ O Selectivity	—		
H ₂ /CO ₂ Selectivity	—	20	80–800
H ₂ /H ₂ S Selectivity	—		
Sulfur Tolerance			
Type of Measurement	—		

Proposed Module Design		<i>(for equipment developers)</i>	
Flow Arrangement	—		
Packing Density	m ² /m ³		
Shell-Side Fluid	—		
Syngas Flowrate	kg/hr		
CO ₂ Recovery, Purity, and Pressure	%/%/bar		
H ₂ Recovery, Purity, and Pressure	%/%/bar		
Pressure Drops Shell/Tube Side	bar	1–2	10

Definitions:

Membrane Geometry – Flat discs or sheets, hollow fibers, tubes, etc.

Pressure Normalized Flux – For materials that display a linear dependence of flux on partial pressure differential, this is equivalent to the membrane's permeance.

GPU – Gas Permeation Unit, which is equivalent to 10⁻⁶ cm³ (1 atm, 0 °C)/cm²/s/cm Hg. For non-linear materials, the dimensional units reported should be based on flux measured in cm³ (1 atm, 0 °C)/cm²/s with pressures measured in cm Hg.

Note: 1 GPU = 3.3464 × 10⁻⁶ kg mol/m²-s-kPa [SI units].

Type of Measurement – Either mixed or pure gas measurements; projected permeance and selectivities should be for mixture of gases found in pre-conditioned syngas.

Flow Arrangement – Typical gas-separation module designs include spiral-wound sheets, hollow-fiber bundles, shell-and-tube, and plate-and-frame, which result in either cocurrent, countercurrent, crossflow arrangements, or some complex combination of these.

Packing Density – Ratio of the active surface area of the membrane to the volume of the module.

Shell-Side Fluid – Either the permeate (H₂-rich) or retentate (syngas) stream.

Other Parameter Descriptions:

Contaminant Resistance – These materials are crystalline silicates and the main issue is stability to steam. Other contaminants are not expected to create problems.

Syngas Pretreatment Requirements – To be determined as project progresses.

Waste Streams Generated – To be determined as project progresses.

technology advantages

This membrane technology will form the selective film using a coating process and premade components, and will have high selectivity, flux, and stability.

R&D challenges

- Dispersible exfoliated layers.
- Simple and efficient coatings process.

results to date/accomplishments

- Synthesis of high aspect ratio exfoliated MCM-22 layers while preserving structure.
- Layer-by-layer coatings of exfoliated MCM-22 layers were fabricated.
- Membranes were tested for separation performance.
- Stability testing was conducted on exfoliated MCM-22 membranes in WGS environment.
- Simulation and optimization studies for IGCC-Membrane Reactor (MR) plant were performed and a techno-economic assessment of IGCC-MR process was completed.

next steps

This project ended on September 30, 2014.

available reports/technical papers/presentations

Tsapatis, M.; Daoutidis, P.; Elyassi, B.; Lima, F.; Iyer, A.; Agrawal, K.; Sabnis, Sanket, Final Report, "Hydrogen Selective Exfoliated Zeolite Membranes," <http://www.osti.gov/scitech/biblio/1178537>, Publication date 09/30/2014.

Tsapatis, M.; Daoutidis, "Hydrogen Selective Exfoliated Zeolite Membranes," Final Project Presentation. <http://www.netl.doe.gov/File%20Library/Research/Coal/carbon%20capture/pre-combustion/2014-12-12-Final-Presentation-DOE-CO2.pdf>.

Tsapatis, M.; Daoutidis, P.; Lima, F.; Elyassi, B. Iyer, A., "Hydrogen Selective Exfoliated Zeolite Membranes," presented at the 2014 NETL CO₂ Capture Technology Meeting in Pittsburgh, PA, July 2014. <http://www.netl.doe.gov/File%20Library/Events/2014/2014%20NETL%20CO2%20Capture/A-Iyer-UMinnesota-Zeolite-Membranes.pdf>.

Tsapatis, M.; Daoutidis, P.; Lima, F.; Elyassi, B. Iyer, A., "Hydrogen Selective Exfoliated Zeolite Membranes," presented at the 2013 NETL CO₂ Capture Technology Meeting in Pittsburgh, PA, July 2013. <http://www.netl.doe.gov/File%20Library/Events/2013/CO2%20Capture/A-Iyer-UMinnesota-H2-Selective-Exfoliated-Zeolite-Membranes.pdf>.

Tsapatis, M.; Daoutidis, P.; Lima, F.; Elyassi, B. "Hydrogen Selective Exfoliated Zeolite Membranes," presented at the 2012 NETL CO₂ Capture Technology Meeting in Pittsburgh, PA, July 2012. <http://www.netl.doe.gov/File%20Library/Events/2012/CO2%20Capture%20Meeting/F-Lima-UMn-Exfoliated-Zeolite-Membranes.pdf>.

Lima, Fernando V.; Daoutidis, Prodromos; Tsapatis, Michael; et al., "Modeling and Optimization of Membrane Reactors for Carbon Capture in Integrated Gasification Combined Cycle Units," *Industrial & Engineering Chemistry Research*, Volume: 51 Issue: 15 Pages: 5480-5489, April 18, 2012. Tsapatis, Michael, Toward High-Throughput Zeolite Membranes, *Science*, Volume: 334 Issue: 6057 Pages: 767-768, November 11, 2011.

Varoon, Kumar; Zhang, Xueyi; Elyassi, Bahman; et al., "Dispersible Exfoliated Zeolite Nanosheets and Their Application as a Selective Membrane," *Science*, Volume: 333 Issue: 6052 Pages: 72-75, October 7, 2011.

Tsapatis, M.; Daoutidis, P.; Lima, F.; Elyassi, B. "Hydrogen Selective Exfoliated Zeolite Membranes," presented at the 2011 NETL CO₂ Capture Technology Meeting in Pittsburgh, PA, August 2011. <http://www.netl.doe.gov/File%20Library/Events/2011/CO2capture/26Aug11--Lima-UMinn-H2-Selective-Zeolite-Membranes.pdf>.

Tsapatis, M.; Daoutidis, P., "Hydrogen Selective Exfoliated Zeolite Membranes," presented at the 2010 NETL CO₂ Capture Technology Meeting in Pittsburgh, PA, September 2010. <http://www.netl.doe.gov/File%20Library/Events/2010/CO2capture/Michael-Tsapatis-FE0001322.pdf>.

Maheshwari, S.; Kumar, S.; Bates, F.S.; Penn, R.L.; Shantz, D.F.; Tsapatis, M. *Journal of the American Chemical Society* 130, 1507-1516 (2008), "Layer Structure Preservation during Swelling, Pillaring and Exfoliation of a Zeolite Precursor."

Choi, J.; Tsapatis, M. *Journal of the American Chemical Society* 132(2), 448-449 (2010), "MCM-22/Silica Selective Flake Nanocomposite Membranes for Hydrogen Separations."

PRESSURE SWING ABSORPTION DEVICE AND PROCESS FOR SEPARATING CO₂ FROM SHIFTED SYNGAS AND ITS CAPTURE FOR SUBSEQUENT STORAGE

primary project goals

The New Jersey Institute of Technology (NJIT) is developing, via laboratory-scale experiments, a pressure swing membrane absorption-based (PSMAB) device using a non-dispersive, membrane-based gas-liquid contactor that produces hydrogen at high pressure for integrated gasification combined cycle (IGCC), as well as a carbon dioxide (CO₂) stream, between 1 and 5 atm, that contains at least 90 percent of the CO₂ from a feed gas at ≈200 °C and 300 pounds per square inch gauge (psig).

technical goals

- Develop, via laboratory experiments, an advanced PSMAB device and a cyclic process to produce helium (He) (a surrogate for hydrogen) at high pressure from low-temperature, post-shift reactor synthesis gas (syngas), as well as a CO₂ stream containing at least 90 percent of the CO₂ and suitable for sequestration.
- Provide data and analysis of the cyclic process and device to facilitate subsequent scaleup.
- Develop a detailed analysis for the process and device to allow economic evaluation for potential larger-scale use.

technical content

In the first phase of research, an experimental setup will be developed for studying the PSMAB process. NJIT will work with Media and Process Technology, Inc., Porogen Inc. and Applied Membrane Technologies (AMT), Inc. to develop microporous hydrophobized ceramic tubule-based, microporous hydrophobized Polyetheretherketone (PEEK) hollow fiber-based and microporous Polytetrafluoroethylene (PTFE) hollow fiber-based absorption devices. The absorption device will be explored on a preliminary basis for performance of PSMAB separation of a moist CO₂-He gas mixture at 150–200 °C and 200–300 psig, simulating a low-temperature, post-shift reactor syngas stream.

technology maturity:

Laboratory-Scale Using Simulated Syngas

project focus:

Pressure Swing Membrane Absorption Device and Process

participant:

New Jersey Institute of Technology

project number:

FE0001323

NETL project manager:

Steven Markovich
markovis@netl.doe.gov

principal investigator:

Dr. Kamalesh K. Sirkar
New Jersey Institute of Technology
sirkar@njit.edu

partners:

Applied Membrane Technologies,
Media and Process Technology,
Porogen,
Techverse

performance period:

10/1/09 – 3/31/13

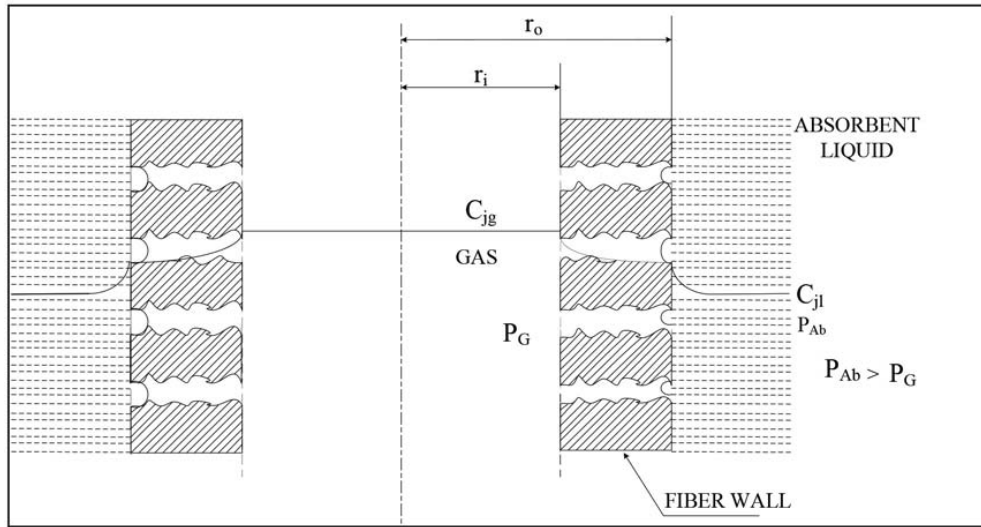

Figure 1: Concentration Profile of Absorbed Species in Gas and Liquid Phases.

In Phase II, NJIT will explore, in detail, the purification and separation performance of the PSMAB process for selected absorbents vis-à-vis purification of the feed gas stream to obtain a high-pressure, purified He stream and a low-pressure, purified CO₂ stream.

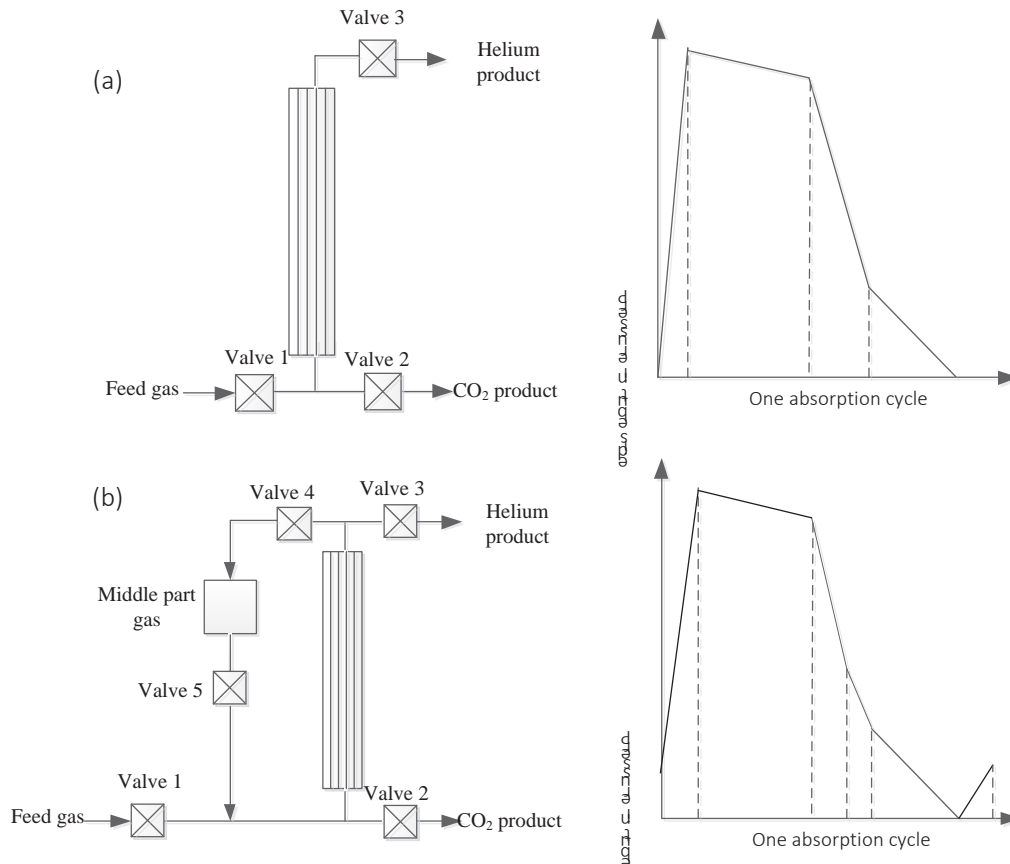

Figure 2: Schematic Diagrams of (a) 3-Valve and (b) 5-Valve Pressure Swing Membrane Absorption Process and the Corresponding Pressure vs. Time Profile in the Bore of the Tubule or Hollow Fiber.

Experimental setups will be developed to measure the solubility and diffusion coefficients of CO₂ and He at the appropriate ranges of temperature and pressure for selected absorbents. Researchers will develop a mathematical model of the PSMAB device and process.

In Phase III, NJIT will generate experimental data on the solubility and diffusion coefficient for CO₂ and He for the selected absorbents. This will allow comparison of the results of simulation of the mathematical model with the observed purification and separation in the PSAB process and device for selected absorbents. Simulations of the model will be performed to explore scale up of the process and facilitate process evaluation. The extent of loss/deterioration of the absorbents over extended periods of operation will be determined.

TABLE 1: LIQUID SORBENT BED PARAMETERS

	Units	Current R&D Value	Target R&D Value
Pure Sorbent			
Molecular Weight	mol ⁻¹	205.26	205.26
Normal Boiling Point	°C	N/A	N/A
Normal Freezing Point	°C	-6	-6
Vapor Pressure at 15 °C	bar	None	None
Manufacturing Cost for Sorbent	\$/kg	Not available	
Working Solution			
Concentration 20% PAMAM dendrimer Gen 0 in [bmim]	Kg/kg	0.25 (dendrimer/[bmim][DCA])	
Specific Gravity (15 °C/15 °C)	g/cm ³	1.08 at room temp.; 1.06 at 65 °C 1.092 (20 wt% dendrimer-[bmim][DCA] mixture) at room temperature	
Specific Heat Capacity at STP	kJ/kg-K	N/A	N/A
Viscosity at STP	cP	106.7 at room temp	
Absorption			
Pressure	bar	13.8–17	13–20
Temperature	°C	100–125	150–200
Equilibrium CO ₂ Loading	mol/mol	0.13	
Heat of Absorption	kJ/mol CO ₂		
Solution Viscosity	cP	25.4 at 65 °C	
Desorption			
Pressure	bar	0.9	1.0
Temperature	°C	100–125	150–200
Equilibrium CO ₂ Loading	mol/mol	0.019	
Heat of Desorption	kJ/mol CO ₂		
Proposed Module Design		<i>(for equipment developers)</i>	
Syngas Flowrate	kg/hr		
H ₂ Recovery, Purity, and Pressure	%/%/bar		
Pressure Drops Shell/Tube Side	bar		

TABLE 2: MEMBRANE-CONTACTOR PARAMETERS

	Units	Current R&D Value	Target R&D Value
Materials Properties			
Materials of Fabrication for Selective Layer	—	fluoropolymer	
Materials of Fabrication for Support Layer	—	ceramic, Teflon, PEEK	
Nominal Thickness of Selective Layer	μm		
Membrane Geometry	—	hollow fiber, shell and tube	
Max Trans-Membrane Pressure	bar	20.4 bar	21 bar
Hours Tested Without Significant Degradation	—	100	1,000
Manufacturing Cost for Membrane Material	\$/m ²	100	
Type of Measurement	—		
Proposed Module Design <i>(for equipment developers)</i>			
Flow Arrangement	—		
Packing Density	m ² /m ³		ceramic: 900 Teflon: 2,000 PEEK: 5,000
Shell-Side Fluid	—		
Syngas Flowrate	kg/hr		
CO ₂ Recovery, Purity, and Pressure	%/%/bar	N/A/85≈90.7/0.2≈1.0	90/95/1.0
H ₂ Recovery, Purity, and Pressure	%/%/bar	N/A/93≈95/5.0≈6.0	95/98/6.0–10.0
Pressure Drops Shell/Tube Side	bar	N/A	N/A

Definitions:

Membrane Geometry – Flat discs or sheets, hollow fibers, tubes, etc.

Pressure Normalized Flux – For materials that display a linear dependence of flux on partial pressure differential, this is equivalent to the membrane's permeance.

GPU – Gas Permeation Unit, which is equivalent to 10⁻⁶ cm³ (1 atm, 0 °C)/cm²/s/cm Hg. For non-linear materials, the dimensional units reported should be based on flux measured in cm³ (1 atm, 0 °C)/cm²/s with pressures measured in cm Hg.

Note: 1 GPU = 3.3464 × 10⁻⁶ kg mol/m²-s-kPa [SI units].

Type of Measurement – Either mixed or pure gas measurements; projected permeance and selectivities should be for mixture of gases found in pre-conditioned syngas.

Flow Arrangement – Typical gas-separation module designs include spiral-wound sheets, hollow-fiber bundles, shell-and-tube, and plate-and-frame, which result in either cocurrent, countercurrent, crossflow arrangements, or some complex combination of these.

Packing Density – Ratio of the active surface area of the membrane to the volume of the module.

Shell-Side Fluid – Either the permeate (H₂-rich) or retentate (syngas) stream.

Other Parameter Descriptions:

Contaminant Resistance – Hydrogen sulfide (H₂S) will not affect the ceramic substrate, nor will it affect the fluoropolymer coating on ceramic and PEEK materials; the Teflon hollow fibers will also remain unaffected. PEEK material is also unlikely to be affected.

Syngas Pretreatment Requirements – Syngas may need to be cooled to 100–125 °C, unless the next round of membrane modules can withstand higher temperature on a continuous basis.

Membrane Replacement Requirements – Device has not been run long enough continuously to define the replacement time. Device will need to run for at least 1,000–3,000 hours.

Waste Streams Generated – Degraded absorption solvent.

Proposed Module Design – Porous hydrophobic hollow-fiber based membrane modules having very limited dead volume at the tube-side headers and tube sheets and connections; the outside diameters of contiguous hollow fibers should not touch each other to allow absorbent in between at the closest distance between adjacent hollow fibers

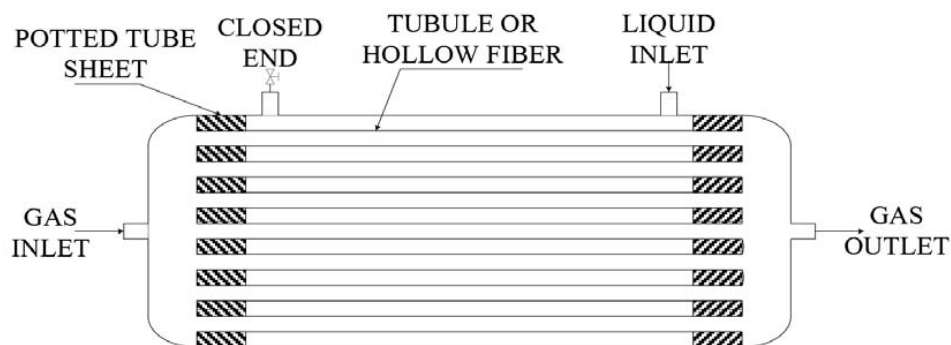

Figure 3: Schematic of Absorber Containing Ceramic Tubules or Hollow Fibers

technology advantages

- High solubility selectivity of novel selected liquid absorbents, high purification ability of the PSA process, and high gas-liquid contacting surface area per unit device volume.
- Compact, membrane-like device.
- Will deliver highly purified hydrogen (H_2) at nearly its partial pressure and temperature in the post-shifted reactor syngas feed.
- Purified CO_2 stream (>90 percent CO_2) will be available at 1 atm.

R&D challenges

- Continuous production of both a higher-purity He stream and a highly purified CO_2 stream requires more modules and altered module configurations. The PEEK hollow-fiber module design has to be changed to achieve higher purification. There is considerable dead volume in the design provided to us resulting in lower CO_2 concentration in the CO_2 -rich stream and higher CO_2 concentration in the He-rich stream.
- Absorbent leaks through microporous PTFE hollow fibers that have a plasma polymerized microporous fluorosilicone coating. These fibers did not develop a high-enough pressure capability and need further development.
- The ceramic tubules have considerable pressure capability but have low surface area per unit volume and are therefore not suitable with current tubule dimensions.

results to date/accomplishments

- Successful testing of PEEK membrane in lab at 250 psig and 100 °C with He/ CO_2 stream.
- Successful testing of ceramic membrane modules in lab at 300 psig without any leakage; extended operation at 120 °C.
- Scale-up of process and device was conducted, including implementation of improved hollow-fiber module design with regard to inter-fiber spacing and fiber surface area in a given module.
- Absorbent liquid was characterized and degradation determined.
- Polyethylene glycol (PEG) 400 is capable of replacing the ionic liquid as the solvent especially in the presence of the dendrimer.
- The PSMAB process was stable with time; the PEEK membrane modules performed much better than ceramic membrane modules to separate CO_2 since PEEK hollow fibers had much higher gas-liquid contacting area per unit gas volume.
- A mathematical model was developed to describe the pressure swing membrane absorption process.

next steps

This project ended on March 31, 2013.

available reports/technical papers/presentations

Jie, X., Chau, J., Obuskovic G. and Sirkar, K. K., "Preliminary Studies of CO₂ Removal from Precombustion Syngas through Pressure Swing Membrane Absorption Process with Ionic Liquid as Absorbent," *I&EC Res.*, 52, 8783-8799 (2013).

Chau, J., Obuskovic, G., Jie, X., Mulukutla, T. and Sirkar, K. K., "Solubilities of CO₂ and Helium in an Ionic Liquid Containing Poly(amidoamine) Dendrimer Gen 0," *I&EC Res.*, 52, 10484-10494 (2013).

Chau, J., Obuskovic, G., Jie, X. and Sirkar, K.K., "Pressure Swing Membrane Absorption Process for Syngas Separation in a 3-valve System: Modeling vs. Experiments," *J. Membrane Sci.*, 453, 61-70 (2014).

Jie, X., Chau, J., Obuskovic, G. and Sirkar, K.K., "Enhanced Pressure Swing Membrane Absorption Process for CO₂ Removal from Shifted Syngas with Dendrimer-Ionic Liquid Mixture as Absorbent," *I&E Chem. Res.*, 53(8), 3305-3320 (2014).

Sirkar, K; Jie, X; Chau, J; Obuskovic, G.; Final Technical Report, June 2013, "Pressure Swing Absorption Device and Process for Separating CO₂ from Shifted Syngas and its Capture for Subsequent Storage." <http://www.osti.gov/scitech/servlets/purl/1097081>.

Sirkar, K.K., "Pressure Swing Absorption Device and Process for Separating CO₂ from Shifted Syngas and its Capture for Subsequent Storage," presented at 2012 NETL CO₂ Capture Technology Meeting, July 2012.

Chau, J.; Xingming, J.; Obuskovic, G.; and Sirkar, K.K., "Pressure Swing Absorption Device and Process for Separating CO₂ from Shifted Syngas and its Capture for Subsequent Storage," presented at 2011 NETL CO₂ Capture Technology Meeting, August 2011. [http://www.netl.doe.gov/File%20Library/research/coal/carbon%20capture/26Aug11-Sirkar-NJIT-PSA-CO₂-from-Syngas.pdf](http://www.netl.doe.gov/File%20Library/research/coal/carbon%20capture/26Aug11-Sirkar-NJIT-PSA-CO2-from-Syngas.pdf).

PRE-COMBUSTION CARBON CAPTURE BY A NANOPOROUS, SUPERHYDROPHOBIC MEMBRANE CONTACTOR PROCESS

primary project goals

Gas Technologies Institute set out to develop cost-effective separation technology for carbon dioxide (CO₂) capture from synthesis gas (syngas) based on a hollow-fiber membrane contactor.

technical goals

- Design an energy-efficient, CO₂ recovery process that minimizes hydrogen loss.
- Tailor highly chemical-inert and temperature-stable, superhydrophobic, hollow-fiber poly (ether ether ketone) (PEEK) membrane for pre-combustion CO₂ capture.
- Manufacture a low-cost integrated membrane module.

technical content

The membrane contactor is a novel gas separation technology, advanced mass transfer device that operates with a liquid on one side of the membrane and gas on the other. Unlike gas separation membranes where a differential pressure across the membrane provides the driving force for separation, the membrane contactor can operate with pressures that are almost the same on both sides of the membrane. The driving force is the chemical potential of CO₂ absorption into the liquid. This process is thus easily tailored to suit the needs for pre-combustion CO₂ capture.

The hollow-fiber membrane is manufactured from an engineered material, called PEEK by PoroGen Corporation, using a patented process. Some key characteristics that make PEEK attractive for this process are: high heat resistance, high rigidity, high dimensional stability, good strength, excellent chemical resistance, excellent hydrolytic stability, an average pore size of 1 to 50 nm, an average porosity of 40 to 70 percent, and an 800-pound per square inch (psi) water breakthrough pressure.

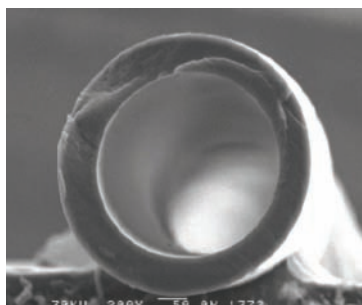

Figure 1: PEEK Hollow Fiber

The PEEK hollow-fiber membrane is nanoporous and can be surface modified to achieve superhydrophobicity; fiber OD can range from 200 μ m to 1mm; and fibers can be made with thin wall (<25 μ) due to the strength of PEEK. The PEEK membrane pore size can be controlled from 1 to 50 nm, and asymmetric membrane structures can be utilized for high performance. The hollow fiber has a high burst pressure of greater than 500 pounds per

technology maturity:

Bench-Scale Using Simulated Syngas

project focus:

Nanoporous, Superhydrophobic Membrane Contactor Process

participant:

Gas Technology Institute

project number:

FE0000646

NETL project manager:

Arun Bose
arun.bose@netl.doe.gov

principal investigator:

Howard Meyer
Gas Technology Institute (GTI)
howard.meyer@gastechnology.org

partners:

PoroGen Corporation
Aker Process Solutions

performance period:

10/1/09 – 3/31/12

square inch gauge (psig), and a high collapse pressure of greater than 1,000 psig.

The advanced hollow-fiber module is constructed by computer-controlled helical winding. The modules exhibit favorable flow dynamics with minimal pressure drop, high uniform packing density, and thermodynamically efficient counter-current flow configuration.

The project was divided into two phases. The activities of Phase I included the development of hollow-fiber membranes suitable for the membrane contactor application with improved mass transfer, establishing feasibility of the proposed technology for syngas CO₂ separation, and performing initial process design and economic analysis based on test data.



Figure 2: Advanced Hollow-Fiber Module Design

The focus of the Phase II activity was to scale-up the process from lab to bench scale. This included scale-up of the membrane module fabrication process so that membrane modules of the size suitable for large-scale application could be manufactured; bench-scale testing of the membrane contactor process stability and sensitivity to process variations; and refinement of the process economics based on bench-test data.

TABLE 1: GTI MEMBRANE PARAMETERS

	Units	Current R&D Value	Target R&D Value
Materials Properties			
Materials of Fabrication for Selective Layer		Perfluoro-oligomer	Perfluoro-oligomer/Polymer
Materials of Fabrication for Support Layer		PEEK	PEEK
Nominal Thickness of Selective Layer	μm	100	100
Membrane Geometry		Hollow Fiber	Hollow Fiber
Maximum Trans-Membrane Pressure	bar	3.4	Maximize
Hours Tested Without Significant Degradation		120	120
Manufacturing Cost for Membrane Material	\$/m ²	Proprietary	Proprietary
Membrane Performance			
Temperature	°C	0 – 50	Maximize
H ₂ Pressure Normalized Flux	GPU or equivalent		
CO ₂ Removal Rate	kg/m ² /h	6	1.5
H ₂ /H ₂ O Selectivity	-	3.7x10 ⁻⁶	3.7x10 ⁻⁶
H ₂ /CO ₂ Selectivity	-	2.65x10 ⁻⁷	2.65x10 ⁻⁷
H ₂ /H ₂ S Selectivity	-	7.5x10 ⁻⁵	7.5x10 ⁻⁵
Sulfur Tolerance	ppm	>100,000	>100,000
Type of Measurement	-	Equilibrium Calculation	Gas Analysis
Proposed Module Design			
Flow Arrangement	-	Counter-Current	Counter-Current
Packing Density	m ² /m ³	500 – 1,000	500 – 1,000
Shell-Side Fluid	-	Water, methanol, aMDEA	Water, methanol, Selexol

TABLE 1: GTI MEMBRANE PARAMETERS

	Units	Current R&D Value	Target R&D Value
Membrane Area/Module	m ²	1	100
Syngas Gas Flowrate	L/min	12	1,200
Solvent Flowrate	L/min	1.2	120
CO ₂ Recovery, Purity, and Pressure	% / % / bar	90/96/5	90/96/5
H ₂ Recovery, Purity, and Pressure	% / % / bar	99/91/50	99/91/50
Pressure Drops Shell/Tube Side	bar	0.4/0.04	0.4/0.04
Estimated Module Cost of Manufacturing and Installation	$\frac{\$}{\text{m}^2}$	\$100	\$40

Definitions:

Membrane Geometry – Flat discs or sheets, hollow fibers, tubes, etc.

Pressure Normalized Flux – For materials that display a linear dependence of flux on partial pressure differential, this is equivalent to the membrane's permeance.

GPU – Gas Permeation Unit, which is equivalent to 10⁻⁶ cm³ (1 atm, 0°C)/cm²/s/cm Hg. For non-linear materials, the dimensional units reported should be based on flux measured in cm³ (1 atm, 0°C)/cm²/s with pressures measured in cm Hg. Note: 1 GPU = 3.3464 × 10⁻⁶ kg mol/m²-s-kPa [SI units].

Type of Measurement – Either mixed or pure gas measurements; projected permeance and selectivities should be for mixture of gases found in pre-conditioned syngas.

Flow Arrangement – Typical gas-separation module designs include spiral-wound sheets, hollow-fiber bundles, shell-and-tube, and plate-and-frame, which result in either co-current, counter-current, cross-flow arrangements, or some complex combination of these.

Packing Density – Ratio of the active surface area of the membrane to the volume of the module.

Shell-Side Fluid – Either the permeate (H₂-rich) or retentate (syngas) stream.

Estimated Cost – Basis is kg/hr of CO₂ in CO₂-rich product gas; assuming targets are met.

Contaminant Resistance – Membrane is resistant to all contaminants. Absorbents will be affected by contaminants to a lesser extent than a conventional packed or tray column.

technology advantages

- Counter-current flow allows for the most efficient mass transfer, thermodynamically.
- Computer-controlled winding provides structured packing to enable enhanced turbulence flow at fiber surface.
- High temperature stability for the desorption step.
- High liquid breakthrough pressure (no liquid wet out), high membrane integrity.
- High membrane productivity.

R&D challenges

- Membrane hydrophobic properties change with solvent contact, causing leakage.
- Mass transfer coefficient of 1.5 kg/m²hr used in the economic evaluation was not sufficiently high for gas absorption in the membrane contactor.

results to date/accomplishments

- Membrane contactor stability and life testing completed.
- 90 percent CO₂ removal from simulated syngas demonstrated.
- High mass transfer coefficients achieved.
- Commercial size membrane contactor designed.
- Slipstream testing completed.

next steps

- The project ended on March 31, 2012.
- Additional module design and testing required to operate with more viscous solvents.
- Scale-up testing with 8-in diameter modules with coal-derived syngas.

available reports/technical papers/presentations

Meyer, H.; Zhou, J.; Bikson, B.; and Ding, Y., “Pre-combustion Carbon Capture by a Nanoporous, Superhydrophobic Membrane Contactor Process,” presented at the 2011 NETL CO₂ Capture Technology Meeting in Pittsburgh, Pennsylvania, August 2011. <http://www.netl.doe.gov/publications/proceedings/11/co2capture/presentations/5-Friday/26Aug11-Meyer-GTI-Pre-Combustion%20Capture%20by%20Nanoporous%20Membr.pdf>.

Zhou, J.; Meyer, H.; and Bikson, B., “Pre-combustion Carbon Capture by a Nanoporous, Superhydrophobic Membrane Contactor Process,” presented at the 2010 NETL CO₂ Capture Technology Meeting in Pittsburgh, Pennsylvania, September 2010. <http://www.netl.doe.gov/publications/proceedings/10/co2capture/presentations/friday/Shaojun%20Zhou%20-%20FE0000646.pdf>.

Meyer, H.; Zhou, J.; and Leppin, D., “Advanced H₂S and CO₂ Removal Technologies for Synthesis Gases”, presented at the 4th International Freiberg Conference of IGCC and Xtl Technologies, Dresden, Germany, May 2010. http://www.gasification-freiberg.org/PortalData/1/Resources/documents/paper/IFC_2010/14-2-Meyer.pdf.

Zhou, S.J.; Meyer, H.; Bikson, B.; and Ding, Y., “Hybrid Membrane Absorption Process for Post Combustion CO₂ Capture.” AIChE Spring Meeting, San Antonio, Texas, March 2010. <http://www.aiche.org/cei/resources/chemeondemand/conference-presentations/hybrid-membrane-absorption-process-post-combustion-co2-capture>.

NOVEL POLYMER MEMBRANE PROCESS FOR PRE-COMBUSTION CO₂ CAPTURE FROM COAL-FIRED SYNGAS

primary project goals

Membrane Technology & Research, Inc. (MTR) set out to develop a new polymer membrane and membrane separation process to capture carbon dioxide (CO₂) from shifted synthesis gas (syngas) generated by a coal-fired integrated gasification combined cycle (IGCC) power plant.

technical goals

Initial technical goals of this project were as follows:

- Investigate novel, high-temperature-stable polymers for use in hydrogen (H₂)/CO₂-selective membranes.
- Prepare composite polymer membranes and bench-scale modules that have H₂/CO₂ selectivities of 10 or higher and hydrogen permeances of greater than 200 gas permeation units (GPU) at syngas cleanup temperatures of 100 to 200°C.
- Optimize membrane process designs, investigate the sensitivity of different proposed processes to membrane performance, and assess the optimal integration of a membrane system into the syngas cleanup train.
- Conduct bench-scale testing of optimized membranes and membrane modules at MTR laboratories with simulated syngas mixtures to evaluate membrane performance and lifetime under expected operating conditions.
- Prepare a comparative evaluation of the cost of the polymer membrane-based separation process versus current cleanup technologies (Rectisol[®], Selexol[®], and PSA) and proposed future membrane reactors.

technical content

The objective of this project was the development of novel, H₂-selective polymer membranes for use in pre-combustion CO₂ capture. The first phase of the project was focused on down-selecting promising membrane materials and scaling-up their production. The optimized membranes produced by this effort (designated as Proteus membranes) show excellent H₂/CO₂ separation properties compared to conventional polymeric membranes. For example, hydrogen permeance of up to 800 GPU and H₂/CO₂ selectivity of greater than 12 were achieved using a simulated syngas mixture at 150°C and 50 pounds per square inch gauge (psig). These values are compared to literature data and the original project target (200 GPU for hydrogen permeance and 10 for H₂/CO₂ selectivity) in Figure 1 in the form of a tradeoff plot. These promising membranes were scaled-up and fabricated into lab-scale modules using high-temperature-stable module components identified during the project. Laboratory testing with simulated syngas mixtures confirmed that the modules (with 100 times the area of membrane stamps) performed as expected.

technology maturity:

Bench-Scale Using Actual Syngas

project focus:

Polymer Membrane Process Development

participant:

Membrane Technology & Research, Inc. (MTR)

project number:

FE0001124

NETL project manager:

Richard Dunst
richard.dunst@netl.doe.gov

principal investigator:

Tim Merkel
Membrane Technology & Research, Inc.
tim.merkel@mtrinc.com

partners:

Southern Company
Tetramer Technologies, LLC

performance period:

9/14/09 – 9/14/11

Following laboratory scale-up, field tests of the optimized membranes and modules using coal-derived syngas were conducted at the National Carbon Capture Center (NCCC) in Wilsonville, Alabama. The main objective of the field tests was to evaluate the long-term stability of membrane or module components at elevated temperatures in the presence of water, sulfur-containing compounds, and heavy hydrocarbons. Figure 2 shows a module housing and one of the bench-scale Proteus membrane modules tested at NCCC. Field results indicate that all membrane and module components were stable in coal-derived syngas (feed pressures: 150 to 175 psig; feed temperatures: 120 to 135°C) for more than 600 hours. The field performance of both Proteus membrane stamps and modules was consistent with the results obtained in the lab, suggesting that the presence of sulfur-containing compounds (up to 780 parts per million [ppm] hydrogen sulfide [H_2S]), water vapor, and heavy hydrocarbons in the syngas feed stream had no adverse effect on performance.

Comparative economic analyses for a number of membrane process designs developed in this project (using H_2 -selective membranes, alone or in the combination with CO_2 -selective membranes) were also performed. The current field performance for Proteus membranes was used in the design analysis. A possible process design for pre-combustion CO_2 capture is shown in Figure 3. It uses a combination of H_2 -selective Proteus membranes and CO_2 -selective membranes. The economic study showed this design has the potential to reduce the increase in Levelized Cost of Electricity (LCOE) for 90 percent CO_2 capture to approximately 15 percent if co-sequestration of H_2S is viable, or 20 percent if H_2S must be removed separately. This value is still higher than the U.S. Department of Energy (DOE) target for increase in LCOE (10%); however, compared to the base-case Selexol process that gives a 30 percent increase in LCOE at 90 percent CO_2 capture, the membrane-based process appears promising. Future improvements in membrane performance have potential to lower the increase in LCOE further.

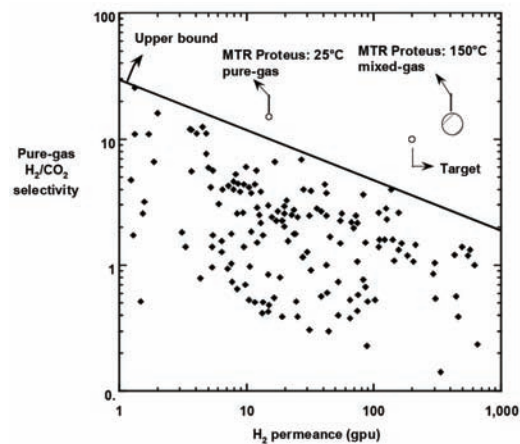

Figure 1: Trade-Off Plot of H_2/CO_2 Selectivity Versus H_2 Permeance

All data points below the upper bound line are for polymeric membranes reported in the membrane literature, and have been translated from pure-gas permeability at 25°C assuming a selective layer thickness of 1 micron. For the mixed-gas measurement, the feed gas is a H_2/CO_2 (50:50 vol%) mixture at 50 psig and 150°C.

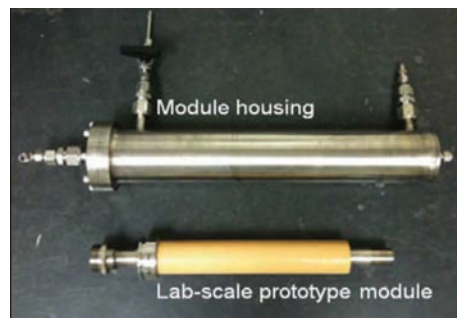

Figure 2: Photos of Module Housing and a Lab-Scale Proteus Membrane Module Tested at NCCC

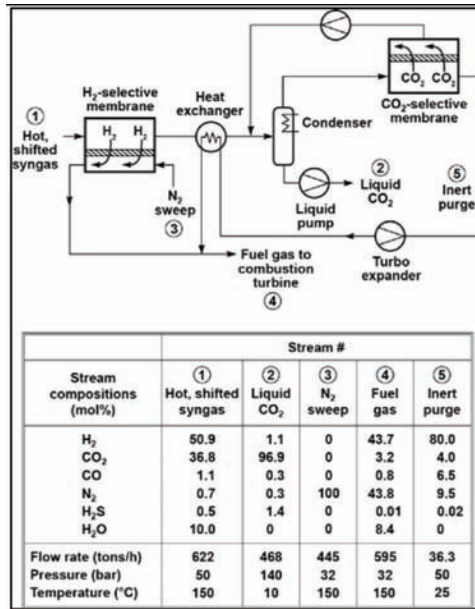

Figure 3: Possible Membrane Process for Pre-Combustion CO₂ Capture that Uses Both H₂- and CO₂-Selective Membranes

TABLE 1: MEMBRANE-BASED CO₂ SEPARATIONS

	Units	Current R&D Value	Target R&D Value
Materials Properties			
Materials of Fabrication for Selective Layer		Polymer	Polymer
Materials of Fabrication for Support Layer		Polymer	Polymer
Nominal Thickness of Selective Layer	µm	0.1	N/A
Membrane Geometry		Spiral wound	Spiral wound
Maximum Trans-Membrane Pressure	bar	12	N/A
Hours Tested Without Significant Degradation		600	N/A
Manufacturing Cost for Membrane Material	\$/m ²	500	N/A
Membrane Performance			
Temperature	°C	120 – 150	150 – 200
H ₂ Pressure Normalized Flux	GPU or equivalent	800	200
H ₂ /H ₂ O Selectivity	-	0.3	N/A
H ₂ /CO ₂ Selectivity	-	15	10
H ₂ /H ₂ S Selectivity	-	30	N/A
Sulfur Tolerance	ppm	780	N/A
Type of Measurement	-	Mixed-gas	Mixed-gas
Proposed Module Design			
Flow Arrangement	-	Cross-flow	Cross-flow
Packing Density	m ² /m ³	700	700
Shell-Side Fluid	-	N/A	N/A
Syngas Gas Flowrate	kg/hr	4	N/A
CO ₂ Recovery, Purity, and Pressure	% / % / bar	90%, 95%, 140 bar	
H ₂ Recovery, Purity, and Pressure	% / % / bar	99%, 92%, 30 bar	

TABLE 1: MEMBRANE-BASED CO₂ SEPARATIONS

	Units	Current R&D Value	Target R&D Value
Pressure Drops Shell/Tube Side	bar	N/A	N/A
Estimated Module Cost of Manufacturing and Installation	$\frac{\$}{\text{kg/hr}}$	20	N/A

Definitions:

Membrane Geometry – Flat discs or sheets, hollow fibers, tubes, etc.

Pressure Normalized Flux – For materials that display a linear dependence of flux on partial pressure differential, this is equivalent to the membrane's permeance.

GPU – Gas Permeation Unit, which is equivalent to $10^{-6} \text{ cm}^3 (1 \text{ atm}, 0^\circ\text{C})/\text{cm}^2/\text{s}/\text{cm Hg}$. For non-linear materials, the dimensional units reported should be based on flux measured in $\text{cm}^3 (1 \text{ atm}, 0^\circ\text{C})/\text{cm}^2/\text{s}$ with pressures measured in cmHg. Note: $1 \text{ GPU} = 3.3464 \times 10^{-6} \text{ kg mol}/\text{m}^2\text{-s-kPa}$ [SI units].

Type of Measurement – Either mixed or pure gas measurements; target permeance and selectivities should be for mixture of gases found in shifted syngas.

Flow Arrangement – Typical gas-separation module designs include spiral-wound sheets, hollow-fiber bundles, shell-and-tube, and plate-and-frame, which result in either co-current, counter-current, cross-flow arrangements, or some complex combination of these.

Packing Density – Ratio of the active surface area of the membrane to the volume of the module.

Shell-Side Fluid – Either the permeate (CO₂-rich) or retentate (flue gas) stream.

Estimated Cost – Basis is kg/hr of CO₂ in CO₂-rich product gas; assuming targets are met.

N/A – Not available or not applicable for this project.

Other Parameter Descriptions:

Membrane Permeation Mechanism – Hydrogen-permeable polymeric membranes developed in this project are rigid glassy materials, where permeation occurs by the solution-diffusion mechanism. The mobility selectivity (which favors hydrogen) governs the separation of H₂ and CO₂.

Contaminant Resistance – The greatest concern would be fouling of the membrane surface due to residual particulate matter or heavy hydrocarbons/tars. Preliminary results from tests at NCCC suggest that existing syngas filters upstream of the membranes will be sufficient to protect the membranes from such surface fouling.

Syngas Pretreatment Requirements – As described above, existing syngas filters should be adequate protection for the membranes. Current temperature limitations on the polymeric membranes require the syngas to be cooled to $\approx 150^\circ\text{C}$ prior to treatment.

Membrane Replacement Requirements – Periodic module replacement is required. The expected lifetime of membrane modules is three to five years.

Waste Streams Generated – The membrane process will not generate any waste streams. Periodic module replacement (expected lifetime of three years) will produce a small amount of solid waste. Typically, for the large membrane applications like sea water desalination by reverse osmosis, these membrane modules are sent to a landfill.

Process Design Concept – A possible process design for pre-combustion CO₂ capture using a combination of hydrogen-permeable Proteus membranes and CO₂-selective membranes is shown in Figure 3. The field performance obtained at NCCC for Proteus membranes was used in the design analysis. Composition and operating conditions for the shifted syngas feed are shown in Table 2.

Proposed Module Design – A spiral-wound membrane module design was used. The hydrogen-enriched stream is produced at lower pressure in the permeate, while the CO₂-enriched stream on the retentate side maintains pressures near those of the syngas feed stream.

TABLE 2: COMPOSITION AND OPERATING CONDITIONS FOR SHIFTED SYNGAS FEED USED IN FIGURE 3 PROCESS DESIGN

Syngas Components	Composition of Shifted Syngas (wet basis, mol %)
H ₂	50.9
CO ₂	36.8
CO	1.1
N ₂	0.7
H ₂ S	0.5
H ₂ O	10.0
Shifted Syngas Feed Operating Conditions	
Pressure	50 bar
Temperature	150°C

technology advantages

- Membranes developed in this project are based on polymer materials that show higher hydrogen permeance and higher H₂/CO₂ selectivity than conventional polymer materials. These membranes can be fabricated into robust, stable, and inexpensive modules of the type currently used commercially in the refinery and natural gas industries to separate gas mixtures at high pressures.
- These polymeric membranes are not sensitive to sulfur species in the syngas feed.
- The process design using both H₂- and CO₂-selective membranes will create a high-pressure CO₂ stream capturing greater than 90 percent of CO₂ in post-shift syngas and fuel gas stream containing greater than 99 percent of the syngas hydrogen. This membrane process has the potential to reduce the increase in LCOE for 90 percent CO₂ capture to approximately 15 percent if co-sequestration of H₂S is viable, and 20 percent if H₂S is removed separately.
- Membranes offer the advantages of simple, passive operation; no use of hazardous chemicals and the subsequent waste handling and disposal issues; no steam use; and a small footprint.

R&D challenges

- Polymer materials that are used in the selective layer and the support layer need to be thermally stable at high operating temperatures.
- Membrane modules to be developed for this application have to endure the extended long-term operations at high temperatures (≈150°C). All the module components, including feed and permeate spacers, support papers, and glues, require new development for this application.
- There is little membrane operational experience with real coal-derived syngas.

results to date/accomplishments

- Confirmed that composite membranes made from novel polymers give hydrogen permeances of at least 200 GPU and H₂/CO₂ selectivities of greater than 10 in bench-scale tests as well as in field tests.
- Completed scale-up of composite membranes on a commercial coater. Lab-scale Proteus membrane modules were also developed using scaled-up Proteus membranes and high-temperature-stable module components identified during this project.
- Completed five, 500-hour slipstream tests of membrane stamps and/or bench-scale membrane modules with coal-derived syngas at NCCC. Both membrane stamps and membrane modules show stable performance treating syngas containing up to 780 ppm H₂S. The average membrane field performance (H₂/CO₂ selectivity of 15 to 25; H₂ permeance of 200 to 300 GPU) exceeds project targets.
- Performed an economic analysis of a number of membrane process designs developed in this project (using H₂-selective membranes, alone or in the combination with CO₂-selective membranes). The field performance at NCCC for Proteus membranes was used in the design analysis. The study showed the current best design has the potential to reduce the increase in LCOE for 90 percent CO₂ capture to approximately 15 percent if co-sequestration of H₂S is viable. This value is still higher than the DOE target for increase in LCOE (10%); however, compared to the base-case Selexol process that gives a 30 percent increase in LCOE at 90 percent CO₂ capture, the membrane-based process appears promising.

next steps

- This project ended on September 14, 2011.
- Future activities should include: (1) continued scale-up of Proteus modules to commercial size elements; (2) increasing the maximum operating temperature of the membrane modules to 200°C; and (3) field testing of an integrated membrane process using H₂- and CO₂-selective membranes.

available reports/technical papers/presentations

T. C. Merkel, M. Zhou, and R. W. Baker; "Carbon Dioxide Capture with Membranes at an IGCC Power Plant;" *J. Membr. Sci.* 389, 441 (2012).

T. C. Merkel, M. Zhou, S. Thomas, H. Lin, A. Serbanescu, and K. Amo, "Novel Polymer Membrane Process For Pre-Combustion CO₂ Capture From Coal-Fired Syngas," presented at 2011 NETL CO₂ Capture Technology Meeting, August 2011.

T.C. Merkel, M. Zhou, S. Thomas, H. Lin, A. Serbanescu, J. Vu, and K. Amo; Novel Polymer Membrane Process for Pre-Combustion CO₂ Capture from Coal-Fired Syngas; Final report submitted to DOE NETL, December 2011.

T. C. Merkel, S. Thomas, M. Zhou, H. Lin, and A. Serbanescu, "Novel Polymer Membrane Process For Pre-Combustion CO₂ Capture From Coal-Fired Syngas," presented at 2010 NETL CO₂ Capture Technology Meeting, September 2010.

M. Zhou, S. Thomas, H. Lin, A. Serbanescu, and T. Merkel, Polymer Membranes For Pre-Combustion CO₂ Capture, 2010 NAMS Annual Meeting & International Conference on Inorganic Membranes.

M. Zhou, S. Thomas, H. Lin, A. Serbanescu, and T. Merkel, Polymer Membranes For Pre-Combustion CO₂ Capture, 2010 AIChE Spring Meeting & 6th Global Congress on Process Safety.

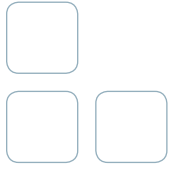

ADVANCED COMPRESSION TECHNOLOGIES



RAMGEN SUPERSONIC SHOCK WAVE COMPRESSION AND ENGINE TECHNOLOGY

primary project goals

Ramgen Power Systems is designing and developing a unique compressor technology based upon aerospace shock wave compression theory for use as a carbon dioxide (CO₂) compressor. A shock wave-based gas turbine engine is also being developed.

technical goals

Phase I

- Complete testing of a high-pressure ratio (8:1) air compressor rotor for the Ram 2 program.
- Demonstrate the feasibility of high-pressure shock wave compression.
- Develop and detail a viable commercialization path.

Phase II

- Perform critical success factors risk reduction validation and test program to identify and reduce technical risk areas.
- Complete general design and demonstration of a CO₂ supersonic shock compressor approximately 13,000 hp in size.
- Complete design, build, and test of multiple engine components to demonstrate supersonic shock compression and advanced vortex combustion in an engine embodiment.

technical content

Shock Wave CO₂ Compressor

Ramgen Power Systems is developing a supersonic shock wave compression technology, similar in concept to an aircraft's ramjet engine, for use in a stationary compressor. Ramgen's compressor design features a rotating disk that operates at high peripheral speeds to generate shock waves that compress the CO₂. Compared to conventional compressor technologies, shock compression offers several potential advantages: high compression efficiency; high, single-stage compression ratios; opportunity for waste heat recovery; and low capital cost. For example, Ramgen's shock compression has the potential to develop compression ratios from 2.0 to 15.0 per stage with an associated adiabatic efficiency of 80–85percent. For CO₂ applications, Ramgen anticipates using a nominal, two-stage 100:1 compression ratio, featuring a matched pair of 10:1 compression stages with an intercooler located between the stages. Testing completed in 2013 achieved a 9:1 compression ratio.

technology maturity:

Pilot-Scale, 2,700
Tonnes/Day CO₂

project focus:

Shock Wave
Compression

participant:

Ramgen Power Systems

project number:

FE0000493
FC26-06NT42651

NETL project manager:

Robin Ames
robin.ames@netl.doe.gov

principal investigator:

Aaron Koopman
Ramgen Power Systems, LLC
akoopman@dresser-rand.com

partners:

Dresser-Rand

performance period:

5/10/2006 – 3/31/2015

When shock waves pass through a gas, they cause a localized compression. Figure 1 shows that the rotating rotor rim has small, shallow angles which, when rotating at high speeds, will produce supersonic shock waves both prior to and post-peak. These shock waves, modeled in the 3-D Euler computational fluid dynamics (CFD) image shown, are first oblique, then normal.

Additionally, strakes (ridges) are incorporated into the design of the rotor to form sidewalls. The strakes are utilized as shock compression ducts, as well as to separate high-pressure discharge from low-pressure suction. The combination of shocks and strakes result in a compressed fluid delivered from a stationary discharge duct with compression efficiencies comparable to conventional industrial turbo-compressors; but with much higher single-stage pressure ratios and therefore higher quality heat of compression that combine to deliver significant installed and operational cost savings versus existing turbo-compressors.

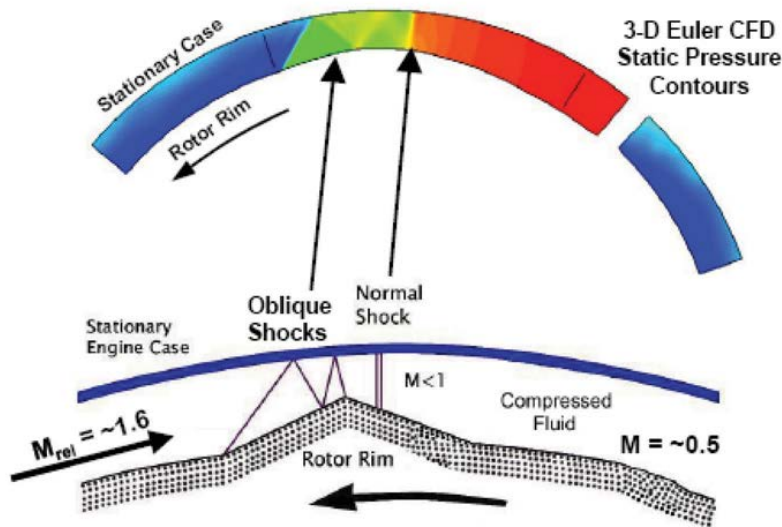

Figure 1: Schematic of Rotor Rim and Engine Case and 3-D Euler CFD Image Depicting Shock Wave Behavior

Two stages of compression are used with an intercooler located between the stages to optimize the efficiency of the compression process. Figure 2 shows the energy required as shaft work and the thermal energy lost to the cooling stream for a 200-MW coal plant with 90 percent CO₂ capture. The numbers found in the figure represent a stage in the process; each stage is driven independently through an external gearbox.

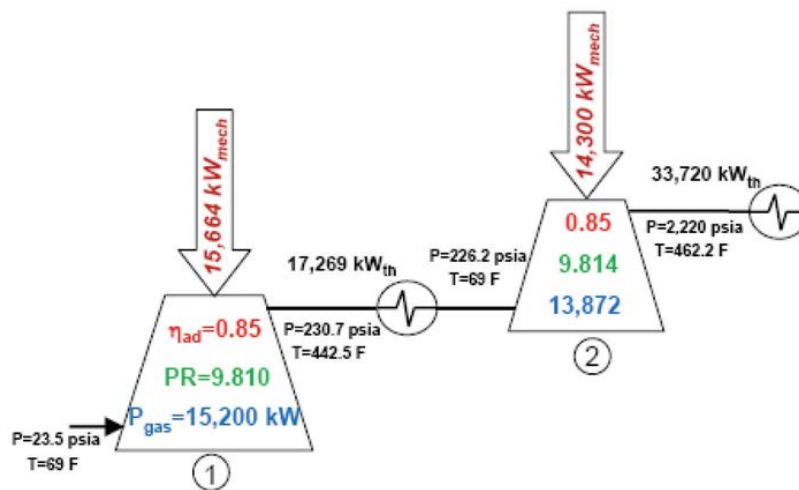

Figure 2: Series Process Schematic

As seen in Figure 2, the total shaft power is 29,964 kW_{mech}, which corresponds to a heat of compression of 50,989 kW_{th}. Approximately 28,986 kW_{th} of the heat of compression lost is recoverable down to 93 °C (200 °F).



Figure 3: Cross Sectional Model of a 1/10th Scale Single-Stage Supersonic Shock Wave Compressor

Shock Wave Gas Turbine Engine

Ramgen is also developing a unique shock wave-based gas turbine engine that is expected to significantly improve energy efficiency. The Ramgen Integrated Supersonic Component Engine (ISCE) consolidates the compressor, combustor, and turbine of a conventional gas turbine into a single wheel that operates based on the same Brayton thermodynamic cycle as a conventional gas turbine; however, the mechanical implementation of the process is quite different. One important advantage is that because the compression, combustion, and expansion processes are all integrated into a single, constant speed rotor, there is no physical acceleration of the rotating components required as the system transitions from idle to full power. The output torque and power are modulated from the full-speed, no-load condition to the full-speed, full-power condition by adjusting the fuel flow. As a result, the system can transition from idle to full power as quickly as the fuel flow can be adjusted. Testing has demonstrated a transition from combustor heat release levels consistent with a power variation from idle (pilot fuel only) to full power (full fuel/air premix) in periods as short as 150–200 milliseconds. This allows the ISCE to load-follow from idle to full power in time scales as short as a few hundred milliseconds compared with a response rate of 7–10 seconds for most intermediate-sized gas turbine electric power generating systems.

The initial proof of concept Ramgen engine used an un-shrouded rotor configuration mounted on a single high-speed shaft driving a generator/starter motor through a speed-reducing gearbox. The ISCE system incorporates a fully shrouded flowpath power-wheel configuration. The reduced size of the components result in a significantly more compact, lightweight, low-cost generation system compared to any other conventional turbo-generator system. One embodiment of this integrated power-wheel system is illustrated in Figure 4 and shows the engine feature of a propulsive flowpath that is fully shrouded and formed by a series of nested rim segments supported by a metal-matrix or polyimide composite outside diameter support ring.

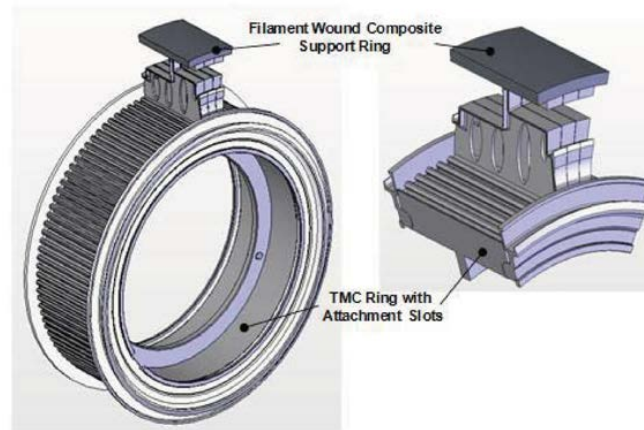

Figure 4: Cross Sectional Model of a 1/10th Scale Single-Stage Supersonic Shock Wave Compressor

technology advantages

- Competitive operating efficiency and reduced installed capital cost (approximately 50 percent) over multistage bladed turbo compressors.
- High-stage discharge temperature enables cost-effective recovery of heat of compression.
 - Improves carbon capture and sequestration (CCS) efficiency.
 - Reduces power plant de-rate.

R&D challenges

- Complicated shock wave aerodynamics on the flowpath requires intensive computing capabilities and model development.
- High rotational speeds and the resulting stresses can result in expensive rotor manufacturing techniques.
- High-pressure ratio compressors yield high rotor thrust loads on bearings and structure.

results to date/accomplishments

- ISCE final design completed.
- Full-speed test rotor runs completed.
- Carbon dioxide compressor and ISCE test (Build 1) equipment have completed testing under full-speed operations.
- Improved “Super Compressor” CO₂ compressor (Build 2) design was completed and testing has started.
- Utilized high-speed performance computing capability at Oak Ridge National Laboratory to analyze compression configurations.
- Advanced Vortex Combustor subcomponent testing in an annular configuration was completed.

next steps

- Improve understanding of the supersonic aerodynamics needed to achieve product performance levels in the CO₂ compressor and engine compressor.
- Complete Build 2 13,000 hp CO₂ compressor testing.

available reports/technical papers/presentations

Lupkes, K., “Ramgen Supersonic Shock Wave Compression and Engine Technology,” presented at the 2012 NETL CO₂ Capture Technology Meeting, Pittsburgh, PA, July 2012.

Grosvenor, A.D.; Zheltovodov, A.A.; Derunov, E.K.; 2012; “Numerical Prediction of 3-D Shock-Induced Turbulent Flow Separation Surrounding Bodies of Revolution Adjacent to a Flat Surface,” EUCASS Book Series on Advances in Aerospace Sciences, Progress in Flight Physics, Eds. Ph. Reijasse, D. Knight, M. Ivanov, and I. Lipatov, Torus Press, ISBN/ISSN: 978-2-7598-0674-4, pp. 119-140.

Baldwin, P., “Ramgen Supersonic Shock Wave Compression and Engine Technology,” presented at the 2011 NETL CO₂ Capture Technology Meeting, Pittsburgh, PA, August 2011.

Grosvenor, A.D.; Zheltovodov, A.A.; Matheson, M.A.; Sailer, L.M.; Krzysztopik, M.; Gutzwiller, D. P.; 2011; “Verification for a Series of Calculated 3-D Shock Wave/Turbulent Boundary Layer Interaction Flows,” Proceedings 4th European Conference for Aerospace Sciences (EUCASS 2011). July 4–8, 2011, Saint Petersburg, Russia. Paper 578.

Lawlor, S., “CO₂ Compression Using Supersonic Shock Wave Technology,” presented at the 2010 NETL CO₂ Capture Technology Meeting, Pittsburgh, PA, September 2010. <http://www.netl.doe.gov/File%20Library/Research/Coal/ewr/CO2/Shawn-Lawlor---Ramgen-Power-Systems.pdf>.

Grosvenor, A.D.; Zheltovodov, A.A.; Derunov, E.K.; 2010; “SWBLI Calculations in Conditions of Aerodynamic Interference of Two Bodies of Revolution with a Flat Surface,” ICMAR, Novosibirsk, Russia.

Lawlor, S., “CO₂ Compression Using Supersonic Shock Wave Technology,” presented at the Annual NETL CO₂ Capture Technology for Existing Plants R&D Meeting, Pittsburgh, PA, May 2009.

Grosvenor, A.D.; Zheltovodov, A.A.; Derunov, E.K.; 2009; “Numerical Prediction of 3-D Shock-Induced Turbulent Flow Separation Surrounding Bodies of Revolution Adjacent to a Flat Surface,” Proceedings of the European Conference for Aero-Space Sciences (EUCASS), Versailles, France.

“Ramgen Power Systems Low-Cost, High-Efficiency CO₂ Compressor,” Seventh Annual Conference on Carbon Capture and Sequestration, May 2008.

Grosvenor, A.D., 2008, “Numerical Studies Toward Prediction, Analysis and Treatment of SWBLI in Transonic Compressors,” Proceedings of the International Conference on the Methods of Aerophysical Research (ICMAR), Novosibirsk, Russia.

Grosvenor, A.D.; Taylor, D.A.; Bucher, J.R.; Aarnio, M.J.; Brown, P.M.; Draper, R.D.; Lawlor, S.P., 2008; “Measured and Predicted Performance of a High Pressure Ratio Supersonic Compressor Rotor,” Turbo Expo 2008 Berlin, GT2008-50150.

Grosvenor, A.D., 2007, “RANS Prediction of Transonic Compressive Rotor Performance Near Stall,” Turbo Expo 2007 Montreal, GT2007-27691.

Grosvenor, A.D.; Brown, P.M.; Lawlor, S.P.; 2006; “Design Methodology and Predicted Performance for a Supersonic Compressor Stage,” Turbo Expo 2006 Barcelona, GT2006-90409.

NOVEL CONCEPTS FOR THE COMPRESSION OF LARGE VOLUMES OF CO₂

primary project goals

Southwest Research Institute (SwRI) is developing novel compression technology concepts to reduce carbon dioxide (CO₂) compression power requirements by 10 percent compared to conventional compressor designs. The basic concept is a semi-isothermal compression process where the CO₂ is continually cooled using an internal cooling jacket rather than using conventional interstage cooling. The project includes thermodynamic testing (Phase I), prototype testing (Phase II), and a full-scale demonstration of a multistage, internally cooled diaphragm pilot test (Phase III).

technical goals

Phase III

- Design and construct a pilot-scale demonstration of a multistage internally cooled compressor diaphragm design.
- Complete a comprehensive thermodynamic and cost analysis of both pulverized coal (PC) and integrated gasification combined cycle (IGCC) plant incorporating the new compression technology.
- Design a multistage diaphragm and test loop.
- Design, fabricate, and test a third-generation cooled diaphragm and test in a single-stage test rig.

technical content

In the cooled diaphragm concept, the gas is continually cooled after each stage in the flow path through the compressor. A cooling jacket insert is used in the diaphragm of each stage to provide continuous cooling. Figure 1 shows a conceptual design for an internally cooled compressor. The flow of the CO₂ is shown in red, while the cooling liquid is shown in blue.

SwRI examined a number of different compression options to find the ones that would consume the least amount of power. Figure 2 shows how two hypothetical compression processes can achieve the same pressure, but still consume different quantities of power. The isothermal compression, even at 60 percent efficiency, requires less power than the isentropic compression at 100 percent efficiency. Therefore, efficiency alone cannot be used as a figure of merit for the compression process.

Figure 3 shows the pressure/enthalpy curves for six of the options examined by SwRI. While liquefaction and pumping is a viable option and may be superior to a pure compression route in cold climates, the semi-isothermal compression proved to be superior when all of the heat exchanger performance and other losses were taken into account.

technology maturity:

Pilot-Scale, 90 tonnes/hr

project focus:

Evaluation of Compression Efficiency Improvements

participant:

Southwest Research Institute

project number:

FC26-05NT42650

NETL project manager:

Travis Shultz
travis.shultz@netl.doe.gov

principal investigator:

Jeffery Moore
Southwest Research Institute
jeff.moore@swri.org

partners:

Dresser-Rand

performance period:

9/28/2005 – 6/30/2014

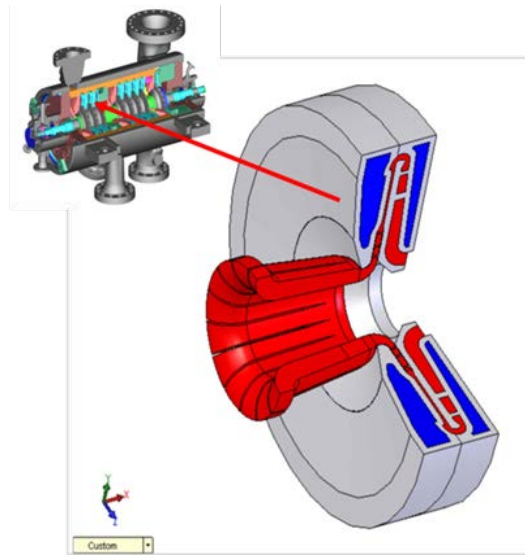

Figure 1: Design for an Internally Cooled Compressor

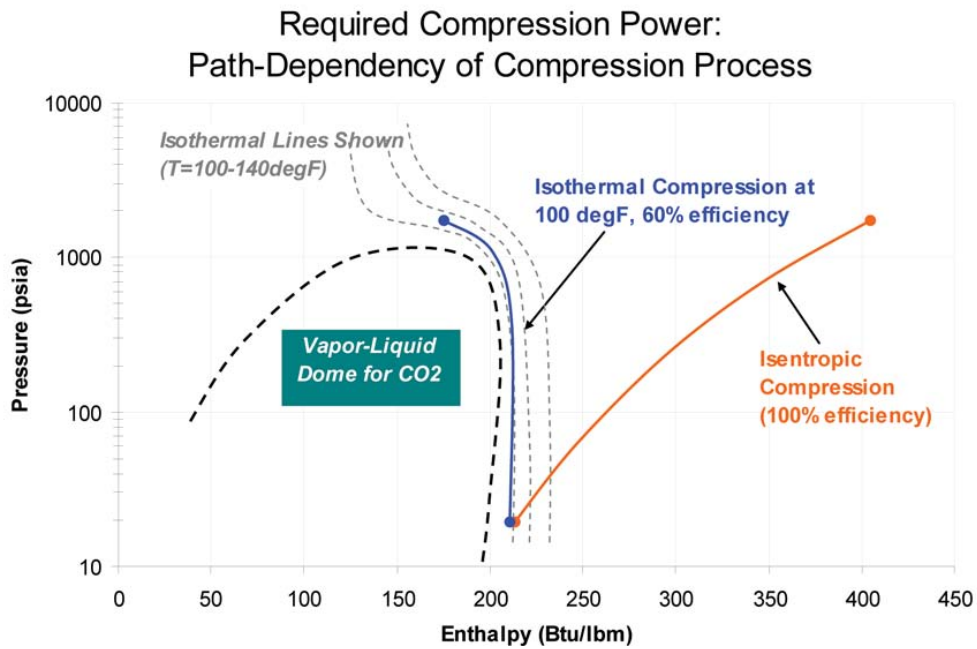

Figure 2: Example of Path Dependency of Compression Power

Compression Technology Options for IGCC Waste Carbon Dioxide Streams

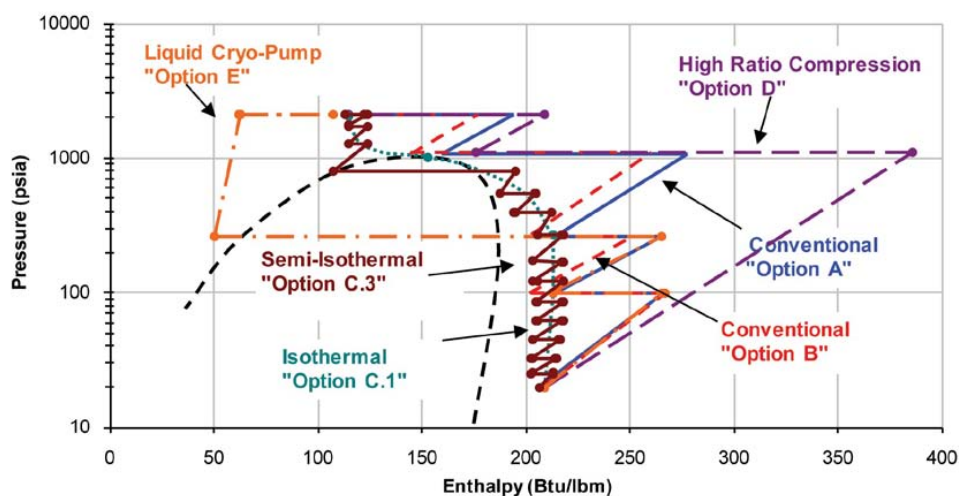

Figure 3: Required Compression Power for the Investigated Technology Options

Table 1 presents a description of the compression and cooling technology options and the resultant power requirements for the U.S. Department of Energy (DOE) 550-megawatt (MW) PC reference power plant with carbon capture using an amine process (≈ 1.3 million lb/hr CO₂ stream, Ramezan 2007)

- Single stream inlet pressure/temperature = 14.8 psia/115 °F
- Discharge pressure = 2,150 psia
- Intercooler/after-cooler exit temperature = 115 °F

The following configurations were analyzed for power comparisons:

1. DOE baseline (efficiencies and refrigeration/ liquefaction cycle performance calibrated to match data in [1])
2. Back-to-back LP and HP compressors with uncooled diaphragms
3. Back-to-back LP and HP compressors with cooled diaphragms, 15 percent effectiveness, 85 °F cooling water
4. Back-to-back LP and HP compressors with cooled diaphragms, 20 percent effectiveness, 85 °F cooling water

The power calculations in this analysis include gas horsepower for compression, cooling horsepower required for liquefaction, pumping horsepower, and gearbox power losses of 2 percent. The estimates exclude bearing and windage losses and power required for the pumping and chilling of cooling water.

The overall compression system analysis results for the methods shown above are displayed in Table 1. A back-to-back compressor with a cooled diaphragm is expected to achieve 10.4–11.7 percent power savings (15–20 percent effectiveness) relative to the DOE baseline case.

TABLE 1. OVERALL COMPRESSION POWER SAVINGS ANALYSIS RESULTS

Case Description	Assumed HX Effectiveness	Power Savings
DOE Baseline	NA	0%
D-R B2B LP and HP Uncooled Diaphragm	0%	6.6%
D-R B2B LP and HP with Cooled Diaphragm	15%	10.4%
D-R B2B LP and HP with Cooled Diaphragm	20%	11.7%

The goal of the current work was to develop and construct a pilot-scale demonstration compression plant to optimize CO₂ compression, as well as perform a balance of plant measurement for total power required and savings realized by improving on the technology developed in Phase II, but in a multi-stage version of the cooled diaphragm design. A new compressor, based on a Dresser-Rand DATUM® D12 frame size, consisted of a six-stage, back-to-back centrifugal compressor (D12R6B) that incorporated the cooled diaphragms. A new test loop with required coolers, valves, and piping was constructed to test this new compressor. The cooled diaphragm, compressor, and loop design, commissioning, and testing will be discussed in this paper. The compressor impeller selection was made for an adiabatic compressor for the design point of 15 psia (1.03 bara) to 250 psia (17.2 bara) for a mass flow of 15.1 lbm/sec (6.85 kg/s). This flow is equivalent to the CO₂ produced by a 35 MW coal fired power plant. The design speed of the compressor is 11,403 rpm and is driven by a 3 MW electric motor through a speed increasing gearbox.

The compressor package was delivered and set, leveled, and bolted to 20 sub-sole plates (Figure 4). Hand valves, control valves, orifice plates, flow conditioners, strainers, and the cooling tower were received and installed. The heat exchangers and piping were assembled and the cooling water supply was tested through the process heat exchangers. The completed pipe assembly is shown in Figure 5. A venting control valve is also used to maintain the desired suction pressure to the compressor. Cooling water was provided to the heat exchangers and compressor diaphragm via an 800 gpm evaporative cooling tower.



Figure 4. Installed Dresser-Rand Datum Compressor Package

The compressor package and pipe loop were commissioned, including oil flush, pipe alignment, shaft alignment, and mechanical testing. All mechanical parameters of the compressor met manufacturer's specifications.



Figure 5. Pipe Loop Assembly Aerial View

Several compressor operating configurations were tested in order to verify compressor performance and determine the effects of the cooled diaphragms. The adiabatic tests (with no cooling water) showed close correlation to the predicted aerodynamic performance maps. These tests established a baseline temperature distribution and power. The liquid cooling system was commissioned and tuned to provide the correct flow distribution to the diaphragms. The subsequent cooled diaphragm testing showed similar head-flow characteristic curves, but slightly higher head and pressure ratio for a given flow due to the increased volume reduction caused by lower stage discharge temperatures.

The polytropic head for varying flow rates from Test 1 is plotted in Figure 6 for the two sections. The adiabatic test points are shown in blue, and the data points for testing with cooling water at the two different flow rates are shown in red and green. The solid black line denotes the predicted adiabatic curve. All data are normalized with respect to the adiabatic test data at the design flow.

The measured adiabatic data were reasonably close to the predicted adiabatic curve, with polytropic head for Sections 1 and 2 measured to be slightly lower and higher than predicted near the design point, respectively. The data also showed that diaphragm cooling changed the characteristics of the speed line slightly by increasing the volume flow capacity for each section, particularly near the choke side of the map. This performance change is attributed to the gas volume reduction that occurred as the gas was cooled in the diaphragm, which caused the latter stages in each section to stay out of choke and operate closer to their design point. The opposite would be true at low flow operation allowing the flow range to be extended by shutting off cooling flow when operating near the surge line. Since the introduction of cooling water affected the head characteristics, the speed during the cooled tests was reduced to match identical discharge pressure as the adiabatic test in order to allow a direct comparison on power.

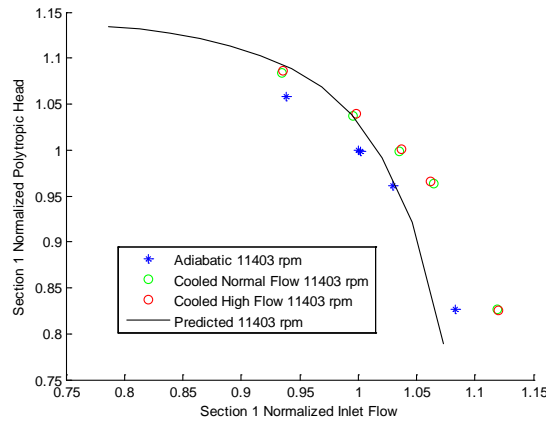

Figure 6. Section 1 Normalized Polytropic Head vs. Normalized Flow (Test 1)

Internal temperature measurements were taken at various points along the compressor. At each of these points, several temperature and pressure measurements were taken at different circumferential locations. These data points were averaged to get a temperature and pressure at each location. For both the adiabatic and cooled cases, the predicted design point temperature was plotted against the actual design point temperature in Figure 7 for Section 1. These results indicate that the adiabatic temperature rise was slightly higher than predicted and cooled temperatures were slightly lower than predicted but showed good agreement overall. The measured discharge temperature was over 100 °F lower for the cooled case.

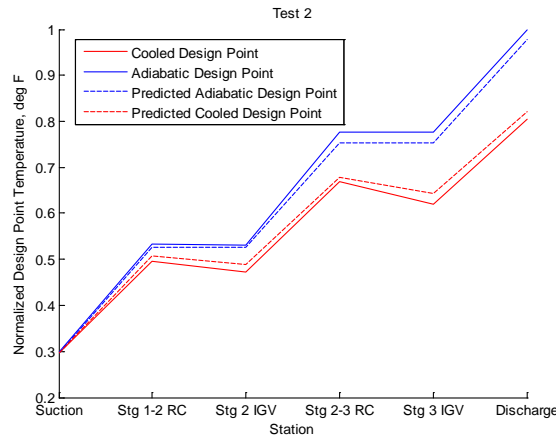

Figure 7. Section 1 Comparison with Predicted Normalized Temperature for Design Flow Conditions

The data show that the cooled diaphragms reduce power consumption by 3–8 percent when the compressor is operated as a back-to-back unit, with the higher power savings at high flow operating points using the high speed torquemeter for reference as shown in Table 2. Additional performance savings could be realized by adding more stages and running the compressor at a slower speed.

TABLE 2. HORSEPOWER PERCENT SAVINGS WITH INTERCOOLER

Point	Adiabatic versus Cooled Diaphragm Difference (%)
1	7.99
2	6.28
3 (design PR)	3.24 (predicted 2.9%)
4	3.03
5	3.01
6	3.32

The results from Test 3 (no intercooling to simulate a straight-through compressor), as shown in Table 3, showed even higher power savings of 9 percent at the design point when matching pressure ratio and speed. Based on the trends seen in back-to-back testing, power savings are expected to be even higher at higher flows exceeding the 10 percent goal of this program.

TABLE 3. HORSEPOWER PERCENT SAVINGS WITH NO INTERCOOLER

Power Savings (%) A. Matching speed and pressure ratio	Power Savings (%) B. Matching flow and pressure ratio
5.64	9.00

technology advantages

- New compression process could use up to 10 percent less power compared to commercially available inline centrifugal compressors.
- Applicable to all types of power plants, including PC, IGCC, and oxy-fuel.
- Could result in significant capital savings and reliability improvement compared to an integrally geared compressor.
- Inline compressors are scalable to large power plants, and their reliability is well proven in LNG and Ethylene service.

R&D challenges

- The wide range of CO₂ output from the power plant based on required electrical output.
- Carbon dioxide compression technology must have high reliability.
- IGCC plants contain multiple CO₂ streams at different pressures.
- The volume reduction during the compression can exceed 500:1.

results to date/accomplishments

- Development complete of multistage internally cooled diaphragm.
- Detailed design of Dresser-Rand DATUM compressor with multistage cooled diaphragms is complete.
- Design of a closed-loop to test back-to-back compressor is complete.
- Pilot-scale demonstration compression plant was developed and constructed.
- Measured the CO₂ baseline compressor performance with and without diaphragm cooling.
- Comparative testing of adiabatic and cooled tests at equivalent inlet conditions shows that the cooled diaphragms reduce power consumption by 3–8 percent when the compressor is operated as a back-to-back unit and over 9 percent when operated as a straight-through compressor with no intercooler.
- The power savings, heat exchanger effectiveness, and temperature drops for the cooled diaphragm were all slightly higher than predicted values.

next steps

This project ended on June 30, 2014.

available reports/technical papers/presentations

Moore, J.J.; et al., “Novel Concepts for the Compression of Large Volumes of CO₂,” presented at the 2013 NETL CO₂ Capture Technology Meeting, July 2013. <http://www.netl.doe.gov/File%20Library/events/2013/CO2%20capture/J-Moore-SWI-Concepts-for-Compression-of-Large-Volumes-of-CO2.pdf>.

Moore, J.J.; et al., “Advance Centrifugal Compression and Pumping for CO₂ Applications,” presented at the 2012 NETL CO₂ Capture Technology Meeting, July 2012. <http://www.netl.doe.gov/File%20Library/Events/2012/CO2%20Capture%20Meeting/J-Moore-SRI-CO2-Compression.pdf>.

Moore, J.J.; et al., “Novel Concepts for the Compression of Large Volumes of CO₂,” presented at the 2010 NETL CO₂ Capture Technology Meeting, Pittsburgh, PA, September 2010.

Moore, J.J.; et al., “Novel Concepts for the Compression of Large Volumes of CO₂ – Phase II,” presented at the Annual NETL CO₂ Capture Technology for Existing Plants R&D Meeting, Pittsburgh, PA, March 2009.

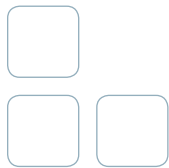

R&D COLLABORATIONS



ADVANCING CO₂ CAPTURE TECHNOLOGY: PARTNERSHIP FOR CO₂ CAPTURE

primary project goals

The University of North Dakota Energy and Environmental Research Center (UNDEERC) is conducting pilot-scale testing to demonstrate and evaluate a range of carbon dioxide (CO₂) capture technologies to develop key technical and economic information that can be used to examine the feasibility of capture technologies as a function of fuel type and system configuration.

technical goals

- Integrate a high-efficiency flexible post-combustion capture system with existing pilot-scale combustion and emission control systems to evaluate the performance of several capture techniques and technologies in flue gas streams derived from selected fossil fuels, biomass, and blends.
- Conduct testing of oxy-combustion for selected fuels and blends in one or more of UNDEERC's existing pilot-scale units.
- Evaluate the performance of emerging CO₂ capture technologies under development and identify key challenges associated with each.
- Perform systems engineering modeling to examine efficient and cost-effective integration of CO₂ capture technologies in existing and new systems.

technical content

UNDEERC is constructing two pilot-scale systems with the intention of performing experiments on several advanced CO₂ capture technologies and comparing them to monoethanolamine (MEA), which is considered to be the current state-of-the-art technology.

Baseline testing will be conducted using MEA to gather information to characterize each of the units. The results obtained by using MEA in the CO₂ absorption system will be used as a standard by which all other solvents will be compared. Data to be collected includes CO₂ removal, CO₂ purity, required regeneration heat, and effects of sulfur oxide (SO_x), nitrogen oxide (NO_x), particulate matter, and trace metals.

Baseline testing of the oxy-combustion system will follow similar procedures as the absorption system. The data collected will be used to identify potential challenges concerning this technology.

These challenges include effects of mercury (Hg) capture, flame stability, fouling, slagging, and heat-transfer issues.

technology maturity:
Pilot-Scale

project focus:
Partnership for CO₂ Capture

participant:
University of North Dakota Energy and Environmental Research Center (UNDEERC)

project number:
**FC26-08NT43291-02.18,
FC26-08NT43291-02.5**

NETL project manager:
Isaac Aurelio
isaac.aurelio@netl.doe.gov

principal investigator:
John Kay
UNDEERC
jkay@undeerc.org

partners:
None

performance period:
6/30/08 – 6/30/15



Figure 1: UNDEERC Post-Combustion CO₂ Capture Test Facility

Once CO₂ capture technologies have been selected, testing will begin. Some of the technologies under consideration include other solvents (monodiethanolamine [MDEA], tailored amines, designer amines, ammonia, and potassium bicarbonate), membranes (metal membranes and carbozyme), and solid sorbents (zeolites, metal-organic frameworks, solid amines, and C-Quest). In addition to testing these technologies, different fuels will be used to evaluate their impact on the performance of the fabricated test units. Factors to be examined will include the effects of SO_x, NO_x, and other gas components; effects of ash deposition along with corrosion of refractory; and alloy components.

UNDEERC has completed the construction of the oxy-combustion system and has begun shakedown testing of the units. UNDEERC has also completed an Aspen model of the solvent absorption and stripping column (SASC) system.

technology advantages

UNDEERC will be capable of providing experimental data for a variety of advanced CO₂ capture technologies and oxy-combustion systems. This information will not only provide needed information for further advancement, but will provide a clear comparison of various approaches.

R&D challenges

Retrieving enough information on existing technologies to make appropriate selections for testing.

results to date/accomplishments

- Completed design and construction of the post-combustion test system for evaluating solvents.
- Completed the oxy-combustion retrofit of the EERC's pilot-scale combustion test facility (CTF).
- Baseline testing with MEA solvent completed in post-combustion test system providing data for comparison with new technologies being tested.
- Test campaign with Huntsman advanced solvent completed, showing higher efficiency and lower cost than MEA.
- Test campaign with advanced Hitachi solvent completed, showing higher efficiency and lower cost than MEA.
- MDEA-piperazine solvent tested.

- Baker Hughes solvent additives, specifically defoaming agents and corrosion inhibitors, tested.
- Huntsman additive to limit solvent degradation from certain flue gas components was tested.
- Solvent samples for corrosion and degradation testing revealed MEA had highest sulfate and thiosulfate.
- Evaluated ION engineering advanced solvent.
- Testing of advanced solvents yielded energy performance 40–50 percent better than the MEA case.
- Physical testing and modeling suggests a post-combustion capture scheme would be less costly than utilizing oxygen-fired technology, with lower capital and operating costs.
- Successfully demonstrated CO₂ capture rate at greater than 90 percent for post-combustion testing and at 75–80 percent for the oxy-combustion retrofit testing. Physical testing and computer modelling indicate the post-combustion scheme is less costly for the conditions tested.
- ASPEN modeling to simulate a 500 MW coal-fired plant retrofitted with oxy-combustion indicated 24.8 percent efficiency with CO₂ capture and 32.9 percent without CO₂ capture. The model estimated the retrofit cost to be \$333.2 million. The cryogenic air separation unit accounted for 62 percent of the cost.
- C-Quest slurry based technology evaluated.
- NETL immobilized amine solid sorbent technology tested.
- Phase II testing completed on advanced solvents including evaluating better heat integration, amine slip testing, corrosion, and solvent reclamation studies in addition to collecting longer steady-state operation data to verify Phase I performance.
 - Cansolv technology using amine-based solvent to pretreat flue gas for SO₂ removal prior to CO₂ capture using natural gas fired flue gas spiked with SO₂. Solvent showed same SO₂ capture with 21 percent less regeneration energy.
 - TriMer pretreatment technology based on ceramic candle filters containing catalysts to convert NO_x and remove particulates was evaluated. Greater than 80 percent NO_x and SO₂ captured when 1.8 mole ammonia used to activate the catalyst.
 - CO₂ Solutions Inc. enzyme-enabled carbon capture technology tested.
 - Amine-based solvent under development by the Korea Institute of Energy Research through the Korea Carbon Capture and Sequestration R&D Center tested. Greater than 95 percent CO₂ capture was observed.

next steps

Complete systems and engineering analyses for each system evaluated.

available reports/technical papers/presentations

Kay, J.P.; Jensen, M.D.; Fiala, N.J., “Pilot-Scale Evaluations of Advanced Solvents for Postcombustion CO₂ Capture,” *Energy Procedia* 2014, 63, 1903–1910.

Kay, J.P.; Fiala, N.J., “Comparative Evaluation of Advanced Postcombustion CO₂ Capture Technologies,” Paper presented at the 38th International Technical Conference on Clean Coal & Fuel Systems, Clearwater, FL, June 2–6, 2013.

Pavlish, B.M.; Kay, J.P.; Laumb, J.D.; Stregge, J.R.; Fiala, N.J.; Stanislawski, J.J.; Snyder, A.C., “Subtask 2.5 – Partnership for CO₂ Capture – Phases I and II”, Final Report (September 1, 2010–April 30, 2013) for U.S. Department of Energy National Energy Technology Laboratory Cooperative Agreement No. DE-FC26-08NT43291; EERC Publication 2013-EERC-08-17; Energy & Environmental Research Center: Grand Forks, ND, August 2013.

Hildebrandt, K.; Kay, J.P., “Integration of Postcombustion CO₂ Capture into Existing Coal-Fired Power Plants,” Topical Report for U.S. Department of Energy National Energy Technology Laboratory Cooperative Agreement No. DE-FC26-08NT43291; Energy & Environmental Research Center: Grand Forks, ND, March 2012.

Laumb, J.D.; Stanislawski, J.J.; Kay, J.P.; Pavlish, B.M., “Evaluation of Advanced Solvents and Other Technologies for CO₂ Capture from Fossil Fuel-Fired Systems” Presented at the 2012 International Pittsburgh Coal Conference, Pittsburgh, PA, October 15–18, 2012.

Pavlish, B.M.; Kay, J.P.; Stanislawski, J.J.; Laumb, J.D., "The Partnership for CO₂ Capture: Final Evaluation Results of Advanced Solvents and Oxy-Fired Combustion Pilot-Scale Testing," Presented at the 36th International Technical Conference on Clean Coal & Fuel Systems, Clearwater, FL, June 5–9, 2011.

Chen, S.G.; Lu, Y.; and Rostam-Abadi, M., "Carbon Dioxide Capture and Transportation Options in the Illinois Basin," Topical Report October 1, 2003–September 30, 2004 for U.S. Department of Energy Contract No. DE-FC26-03NT41994.

Metz, B.; Davidson, O.; Coninik, H.; Loos, M.; and Meyer, L. "IPCC Special Report Carbon Dioxide Capture and Storage Technical Summary," ISBN 92-9169-119-4, September 2005.

Narula, R.; Wen, H.; and Himes, K., "Economics of Greenhouse Gas Reduction – The Power Generating Technology Options," Presented at the World Energy Congress, Buenos Aires, Brazil, October 2001.

FUTURE OF CCS TECHNOLOGY ADOPTION AT EXISTING PC PLANTS

primary project goals

Argonne National Laboratory (ANL) is constructing scenarios that affect carbon capture and storage (CCS) adoption as combinations of cases for the following dimensions: electricity demand, nuclear plants, renewable energy growth, higher or lower gas price factors, and alternative policies.

technical goals

- Extension of ANL's previous work in project FWP49539, "Evaluation of CO₂ Capture/ Utilization/Disposal Options."
- Simulate oxy-combustion and amine-based processes using ASPEN.
- Expand the scenario analyses to focus on the value of coal-based CCS for existing pulverized coal (PC) plants and for other technologies, such as coal-to-liquids with CCS.
- ANL will examine pathways that expedite CCS adoption, such as accelerated research and development (R&D) and carbon dioxide (CO₂) utilization for enhanced oil recovery (EOR).
- ANL will examine opportunities for R&D related to shale gas, such as developing CCS specifically for natural gas combined cycle (NGCC) units.

technical content

In a previous project (FWP49539), ANL conducted engineering assessments and economic evaluations on retrofitting PC boilers with oxy-combustion, and then eventually repowering the site with integrated gasification combined cycle (IGCC). The engineering assessment for oxy-combustion was conducted with the ASPEN process model and the economic evaluations with the AMIGA macroeconomic model. The assessment investigated the entire life cycle of the plant, which included the mining of the coal, coal transportation, coal preparation, power generation, environmental controls, water use, pipeline CO₂ conditioning, and pipeline transport of CO₂ for sequestration.

ANL also conducted ASPEN modeling for 18 different oxy-combustion and air-fired cases. Three different power production ratings (150 MW, 300 MW, and 450 MW) were investigated. The model included a selective catalytic reduction (SCR) system and a flue gas desulfurization (FGD) system for flue gas cleanup.

technology maturity:

Systems Analysis and Macroeconomic Modeling

project focus:

Analysis of CCS Technology Adoption

participant:

Argonne National Laboratory

project number:

**FWP49806
continued from
FWP49539**

NETL project manager:

José Figueroa
jose.figueroa@netl.doe.gov

principal investigator:

Donald Hanson
ANL
dhanson@anl.gov

partners:

None

performance period:

2/1/11 – 3/31/14

The analysis in the current project will demonstrate and, to the extent possible, quantify the role and benefit of R&D related to the utilization and environmental control of fossil fuels. The impacts of R&D will be shown by comparing model results such as deployment rates, emissions reductions, and electricity costs across various scenarios. The scenarios will capture a number of CO₂ control regimes, R&D programs, and economic conditions in order to fully understand the role that R&D plays in each. With widespread deployment of CCS under a CO₂ reduction target, R&D that lowers cost of CO₂ capture and increases efficiency will be shown to have a high economic payoff.

Other topics to be analyzed with the ANL model are as follows: the value of coal-based CCS in high natural gas price scenarios; opportunities and obstacles for R&D, on NGCC with CCS, including cost and performance parameters; the conditions under which CO₂-EOR enables faster deployment of CCS systems; the market opportunity for coal and biomass to liquid fuels and power co-production with CCS; and impacts on PC units, especially those retrofitted with CCS, from cycling due to intermittent grid generation from renewables.

technology advantages

The ANL model is especially designed to analyze the issues and scenarios described above.

R&D challenges

Capturing the impacts and costs of high intermittent renewable generation as it affects dispatchable coal generators, especially those that have adopted CCS.

results to date/accomplishments

- Ran Electricity Supply and Investment Model (ESIM) for high, mid, and low gas supply scenarios to identify retirement of existing PC power plants which do not retrofit with CCS and to identify the retrofit with CCS of other current PC plants.
- Modeled predicted increased CO₂ capture and decreased CO₂ emissions for the scenarios.
- Simulated the benefit of higher utilization (i.e., capacity factor) for PC plants that retrofit CCS because of rising up the loading order (i.e., dispatch order).
- Analyzed the value of coal-based CCS in high natural gas price scenarios.
- Analyzed opportunities and obstacles for R&D, specifically regarding CCS, including cost and performance parameters.
- Analyzed market opportunity for coal and biomass to liquid fuels and power co-production with CCS.
- Analyzed impacts on PC units, especially those retrofitted with CCS, from cycling due to intermittent grid generation from renewables.
- Concluded funding for R&D for CCS, nuclear, and biochemical technologies can help meet CO₂ reduction goals.
- Concluded credits for reducing CO₂ or small price on emitting CO₂ will provide incentive to operate units with CCS at higher utilization than units without capture.
- Concluded electricity prices can be moderated for consumers and businesses if revenue from a modest price on CO₂ is recycled back to help fund investments in advanced generation capacity.

next steps

This project ended on March 31, 2014.

available reports/technical papers/presentations

Hanson, D. and Schmalzer, D, “An Adoption Scenario for Carbon Capture in Pulverized Coal Power Plants in the USA,” *Greenhouse Gases Science and Technology* (3:p.303-308), 2013.

Hanson, D. “Future of CCS Technology Adoption at Existing PC Plants,” presented at CO₂ Capture Technology Meeting, Pittsburgh, PA, July 2013. [http://www.netl.doe.gov/File_Library/events/2013/CO₂ capture/D-Hanson-ANL-Future-of-CCS.pdf](http://www.netl.doe.gov/File_Library/events/2013/CO2_capture/D-Hanson-ANL-Future-of-CCS.pdf).

Hanson, D., and Schmalzer, D., “CCS Adoption Under Alternative Market Conditions,” presented at U.S. Association for Energy Economics Conference, Austin, TX, November 2012.

Hanson, D., “Economics and Adoption of CO₂ Capture for Existing PC Plants in a Power System Context,” Eleventh Annual Conference on Carbon Capture, Utilization & Sequestration, Pittsburgh PA, May 2012.

Hanson, D., “Future of CCS Technology Adoption at Existing PC Plants,” presented at CO₂ Capture Technology Meeting, Pittsburgh, PA, July 2012.

Hanson, D.; Marano, J.; and Fout, T., “Economic Analysis of Existing Coal Plant Retrofits with CCS,” Energy, Utility, & Environmental Conference, Phoenix AZ, January 2012.

Hanson, D., “A Market Scenario Approach to Managing Existing Power Plant Assets,” 13th Annual Electric Power Conference and Exhibition, Rosemont, IL, May 2011.

Hanson, D., and Doctor, R., “Future of CCS Technology Adoption at Existing PC Plants,” presented at CO₂ Capture Technology Meeting, Pittsburgh, Pennsylvania, August 2011.

“ANNUAL REPORT 2009: Evaluation of CO₂ Capture and Sequestration Using Oxyfuels with AMIGA Economic Modeling,” November 23, 2009.

Doctor, R.; Hanson, D. A.; and Molburg, J. C., “Evaluation of CO₂ Capture and Sequestration Using Oxyfuels with AMIGA Economic Modeling,” presented at 2009 NETL Capture Technology Meeting, March 2009.

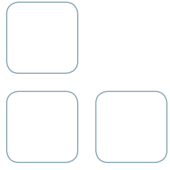

NETL-RESEARCH AND INNOVATION CENTER TECHNOLOGIES



TRANSFORMATIONAL SOLVENTS

primary project goals

Develop advanced materials and processes that are able to reduce the energy penalty and cost of CO₂ separation over conventional technologies.

technical goals

Develop new, breakthrough pre- and post-combustion liquid solvent materials by designing, synthesizing, characterizing, and performance testing these materials.

technical content

Liquid solvent processes are the most well-developed technology for CO₂ separation. A circulating solvent that passes between absorption and desorption columns is the most typical process configuration. However, solvent materials can be improved in several ways and may be able to serve as a drop-in replacement in a standard process. Some potential improvements include (1) reducing the required regeneration energy, (2) decreasing viscosity, (3) increasing sorption capabilities at elevated temperature, (4) increasing the resistance to contaminants such as water or sulfur species, and (5) use of a material that phase separates upon exposure to CO₂, requiring regeneration of a reduced portion of the solvent.

Improvements in material performance can be achieved through modifications to the structure or formulation of the solvent material. When appropriate, computational methods have been used to guide structure and formulation modifications.

Solvents can be performance tested using onsite facilities such as the continuously-stirred test reactor (CSTR) or offsite at facilities using actual flue or fuel gas.

The standard, commercially-available physical solvents for CO₂ capture are Selexol® (Union Carbide, Houston, TX, US) and Rectisol® (Lurgi AG, Frankfurt am Main, DEU.) Both of these solvents are hydrophilic, which means that water vapor must be removed prior to the absorption column by lowering the temperature of the syngas to below 40 °C. Lowering the temperature, removing the water vapor, and then raising the temperature back to ≈200 °C is inefficient from both a cost and net electricity perspective. Hydrophobic solvents could be operated at higher temperatures and minimize the energy and cost penalties associated with cooling the syngas to below 40 °C.

technology maturity:

Laboratory Scale or Pilot Scale, Actual Flue Gas Slipstream

project focus:

Pre- and Post-Combustion Liquid Solvents

participant:

National Energy Technology Laboratory—Research and Innovation Center

project number:

RIC Capture FY2016–2020 FWP

NETL project manager:

David Hopkinson
david.hopkinson@netl.doe.gov

principal investigator:

Nick Siefert
nicholas.siefert@netl.doe.gov

partners:

N/A

performance period:

10/1/15 – 9/30/16

As such, the research is focused on finding materials that are hydrophobic so that they can be operated at temperatures between 40 °C and 200 °C and in the presence of water vapor. A particular focus has been placed on the testing of materials to determine their CO₂ solubility, kinetics, mass transfer, regeneration energy, and stability. Each of these properties is a parameter that may be tuned in solvent development, so their effect on CO₂ separation energetics, and ultimately cost, serves to guide materials development. Equally important, system and economic studies are being conducted to determine how these material properties affect the overall performance of the pre-combustion capture system.

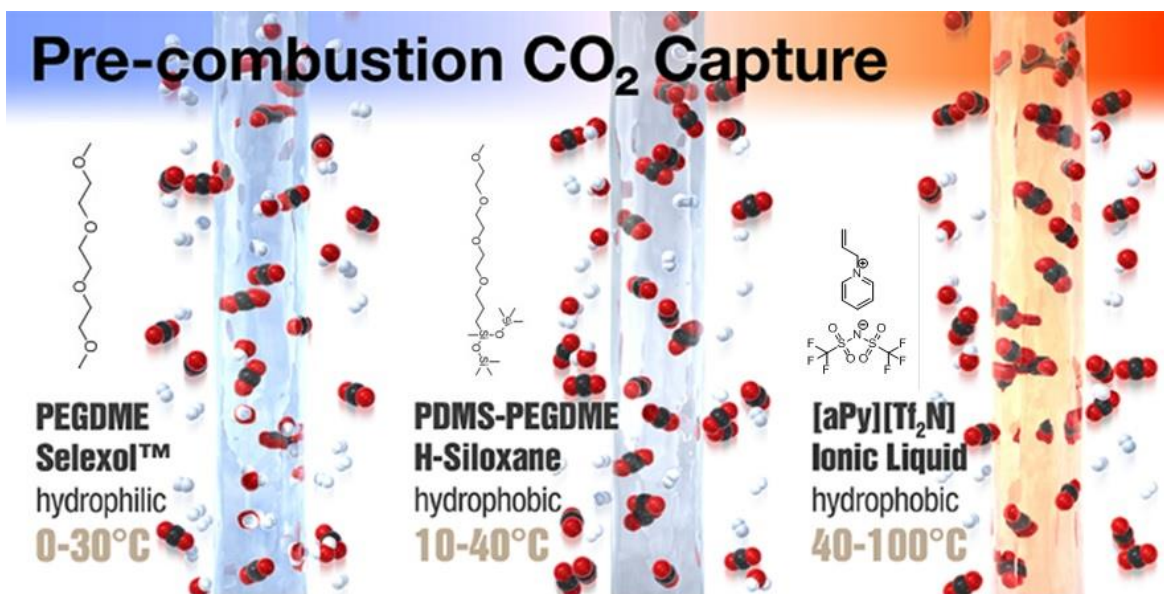

Figure 1: Two Promising Physical Solvents Being Tested to Replace Selexol™: Hybrid PDMS-PEGDME and Ionic Liquid Allyl Pyridinium [aPy][Tf₂N].

technology advantages

The hydrophobic nature of the physical solvents being developed can allow pre-combustion CO₂ capture to occur at higher temperatures when water vapor will be present in the syngas. Operating at higher temperature can decrease power consumption and capital costs associated with CO₂ capture from syngas because of the better temperature match of the CO₂ process with the processes upstream (water gas shift) and downstream (combustion) of CO₂ capture.

R&D challenges

- Due to the revolutionary nature of the transformational solvent technologies, the majority of the materials and systems examined in this research may not succeed.
- Challenges for solvent process include (1) improving solvent working capacity, (2) increasing the CO₂/H₂ selectivity of the solvent, (3) increasing hydrophobicity, (4) decreasing viscosity, and (5) optimizing solvents for temperature, pressure, and gas mixture conditions specific to its application.

results to date/accomplishments

- NETL has developed a hydrophobic physical solvent (HPDMS) with a CO₂ solubility greater than the physical solvent used in NETL's baseline integrated gasification combined cycle (IGCC)-CCS reports, i.e., Selexol™.
- NETL has developed and submitted a patent applications for a low viscosity ionic liquid [aPy][Tf₂N] that has nearly the same CO₂ solubility and CO₂/H₂ selectivity as Selexol®, but which is hydrophobic and which can be operated and regenerated at significantly higher temperature than Selexol™.
- HPDMS and [aPy][Tf₂N] are miscible, which means that we have developed a hydrophobic solvent with qualities that can be tailored to the particular application.

next steps

One or both of these physical solvents listed above is expected to be an economically-viable replacement for Selexol® and Rectisol® in pre-combustion capture of CO₂ from syngas fuel streams at IGCC power plants. These solvents are being evaluated under realistic testing conditions testing in the presence of real fuel gas at the University of Kentucky or at the National Carbon Capture Center, and if fully successfully, promising solvents will be slated for testing at successively larger scales. Patent development by NETL can allow these technologies to be transferred to industrial partners for further scaleup and commercialization.

available reports/technical papers/presentations

Shi, W., Siefert, N.S.S., and Morreale, B.D., "Molecular Simulations of CO₂, H₂, H₂O, and H₂S Gas Absorption into Hydrophobic Poly(dimethylsiloxane) (PDMS) Solvent: Solubility and Surface Tension," *J. Phys. Chem. C*, 119 (33), pp 19253–19265 (July 2015).

Siefert, N.S., Agarwal, S., Shi, F., Shi, W., Roth, E.A., Hopkinson, D., Kusuma, V.A., Thompson, R.L., Luebke, D.R., and Nulwala, H.B., "Hydrophobic physical solvents for pre-combustion CO₂ capture: Experiments, Computational simulations, and Techno-economic analysis," *International Journal of Greenhouse Gas Control*, In Review.

Fan Shi, Nicholas Siefert, and David Hopkinson, "Anti-foaming Study for Physical Solvents for Pre-Combustion CO₂ Capture," 2015 AIChE Annual Meeting, Salt Lake City, November 8–13, 2015.

Nicholas Siefert, Hunaid Nulwala, Wei Shi, Fan Shi, Jeffrey Culp, Elliot Roth, Victor Kusuma, David Hopkinson, "Warm Gas Precombustion CO₂ Capture Using Hydrophobic Solvents," 2015 International Pittsburgh Coal Conference, Pittsburgh, PA, October 5–8.

Fan Shi, Brian Kail, Hunaid Nulwala, Nicholas Siefert, David Luebke, "Effects of Contaminants on Pre-combustion CO₂ Capture Solvents," 18th Annual Energy, Utility & Environment Conference (EUEC), San Diego, CA, Feb 16–18, 2015.

Siefert, N., Sweta, A., Nulwala, H., Roth, E., Kusuma, V., Shi, F., Shi, W., Culp, J., Miller, D., Hopkinson, D., Luebke, D., "Hydrophobic, Physical Solvents for Pre-combustion CO₂ Capture: Experiments and System Analysis," Fourteenth Annual CCUS Conference, Pittsburgh, PA, April 30, 2015.

Siefert, N., Sweta, A., Nulwala, H., Roth, E., Kusuma, V., Shi, F., Shi, W., Culp, J., Narburgh, S., Miller, D., Hopkinson, D., "Hydrophobic, Physical Solvents for Pre-combustion CO₂ Capture: Experiments and System Analysis," 2015 NETL CO₂ Capture Technology Meeting, Pittsburgh PA, June 25, 2015.

TRANSFORMATIONAL SORBENTS

primary project goals

Develop advanced materials and processes that are able to reduce the energy penalty and cost of CO₂ separation over conventional technologies.

technical goals

Develop new, breakthrough pre- and post-combustion solid sorbent materials by designing, synthesizing, characterizing, and performance testing these materials.

technical content

Sorbent processes require a material that can absorb the CO₂ and then be regenerated. Research results will be gathered from thermogravimetric analysis for sorbent refinement data and kinetic information, laboratory- and bench-scale packed bed reactor tests for process and kinetic information, calorimetry for sorbent thermodynamic properties, and various types of analytical techniques for mechanistic determinations.

Novel breakthrough sorbent materials include porous organic polymer (POP) for carbon dioxide capture and separation. The primary sorbent candidate to date is BILP-101, a novel porous benzimidazole-linked polymer prepared in a simple one step reaction using commercially available building blocks. BILP-101 has ultra microporosity and high chemical and thermal stability. High nitrogen to carbon ratio in the polymer enhances CO₂ uptake and CO₂/N₂ selectivity. POP-based sorbents will be performance tested at laboratory scale and under ideal conditions. Initial apparatus will include thermogravimetric analysis (TGA) evaluation using a Hiden system to obtain single and dual gas sorption isotherms using CO₂ and H₂O. Larger scale testing can occur using a packed bed reactor having both CO₂ and H₂O in the feed gas with the reactor effluent monitored using mass spectrometry. Experimentally measured performance parameters can then be provided to Carbon Capture Simulation Initiative models to perform simulations and system studies.

technology maturity:

Bench Scale through Pilot Scale, with Actual Flue Gas

project focus:

Pre- and Post-Combustion Solid Sorbent Materials

participant:

National Energy Technology Laboratory—Research and Innovation Center

project number:

RIC Capture FY2016–2020 FWP

NETL project manager:

David Hopkinson
david.hopkinson@netl.doe.gov

principal investigator:

Jim Hoffman
james.hoffman@netl.doe.gov

partners:

N/A

performance period:

10/1/15 – 9/30/16

technology advantages

A single successful transformational sorbent technology has the potential to alter the landscape of carbon capture.

R&D challenges

- Due to the revolutionary nature of the transformational sorbent technologies, the majority of the materials and systems examined in this research may not succeed.
- Challenges for sorbent processes include (1) achieving reasonable working capacities within the temperature envelope of 40–110 °C, (2) minimizing the impact of flue gas moisture, (3) reducing the regenerative heat duty so that it is 30–50 percent less than that of the monoethanolamine (MEA) wet scrubbing process, (4) identifying the chemical and mechanical properties of the sorbent important to durability and stability, and (5) obtaining engineering information on the physical properties of the sorbents that will lead to the scaleup of the sorbent process to the pilot scale.

results to date/accomplishments

Ultra-Micro Porous Organic Polymer for High Performance Carbon Dioxide Capture and Separation

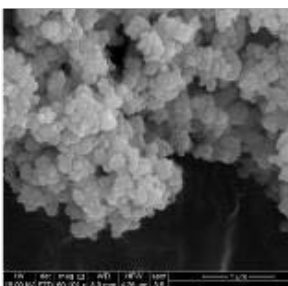
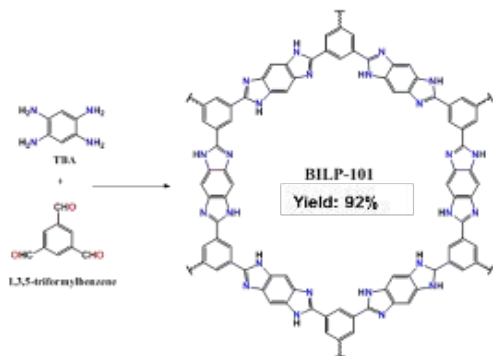

BILP-101 Sorbent:

- Rationally designed pore size (0.54 nm).
- Simple one-step preparation; no metal catalyst and template.
- High chemical (acid/base) and thermal stability (>600 C)
- Very high CO₂ uptake (4 wt% at 0.15 bar and 298K) and record CO₂/N₂ selectivity (80).
- Optimum heats of adsorption for CO₂ (33 kJ/mol)
- Highly regenerable CO₂ adsorption behavior, no thermal activation is needed

Sorbent	ΔN_1	S
BILP-101	0.80	556
SNU-CL-va	0.41	262
Zeolite-13X	1.35	128
ZIF-MOF	0.58	396
MOF-4b	0.06	104
HKUST-1	0.55	46.2
NoritR1-extra (activated carbon)	0.28	5.09

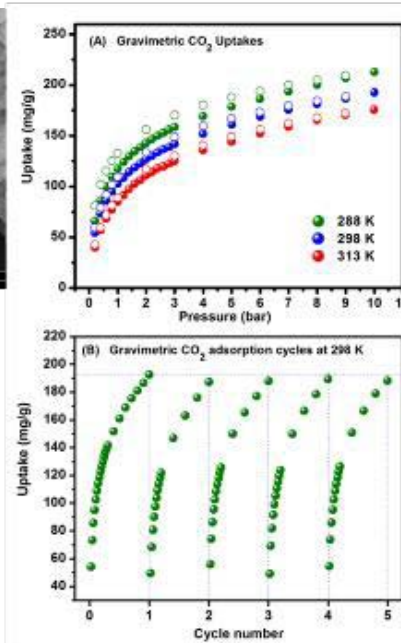

next steps

- Each material will be rapidly evaluated under ideal laboratory conditions to determine suitability for continued development.
- Materials that show promise will continue for additional development under more realistic conditions, including testing with simulated, and ultimately, actual flue/fuel gas.
- Ongoing development efforts will focus on, but not be limited to, improving CO₂ working capacity and hydrophobicity; lowering heat capacity; increasing chemical and mechanical stability; and optimizing the sorbent for the temperature, pressure, and gas mixture conditions that are specific to its application.

available reports/technical papers/presentations

“Ultra-Micro Porous Organic Polymer for High Performance Carbon Dioxide Capture and Separation,” Chem. Commun. 2015 DOI: 10.1039/C5CC04656D, Sekizkardes, A; Culp, J. T.; Islamoglu, T.; Marti, A.; Hopkinson, D.; Myers, C.; El-Kaderi, H. M.; Nulwala, H.

Ali Sekizkardes, David Hopkinson, “Ultramicroporous Polybenzimidazole for Selective Gas Capture,” Report of invention filed with NETL, September 23, 2015.

James Hoffman, Gray, M., Wilfong, C., Kail, B. “Basic Immobilized Amine Sorbents (BIAS) for Post Combustion CO₂ Capture.” Poster presented at 2015 NETL CO₂ Capture Technology Meeting, June 23–26, 2015, Pittsburgh, PA.

Pennline, H., Hoffman, J., Gray, M., Siriwardane, R., Fisher, J. “NETL/ORD Sorbent Research for the Capture of Carbon Dioxide.” NETL topical report (final draft) submitted for review December, 2015.

TRANSFORMATIONAL MEMBRANES

primary project goals

Develop advanced materials and processes that are able to reduce the energy penalty and cost of CO₂ separation over conventional technologies.

technical goals

Improve permeance and selectivity over conventional polymeric materials by employing a composite approach: mixed matrix membranes use a polymeric matrix with high permeability metal organic framework (MOF) filler particles to enhance the performance of the membrane.

technical content

The intrinsic trade-off between permeability and selectivity is one of the limitations of using polymer membranes in CO₂ capture. Incremental improvements in polymer performance continue to advance the trade-off curve toward more selective, more permeable materials, but a step-change over current technology would facilitate wider implementation of membranes in industry. Mixed matrix membranes (MMMs) are a technology that could potentially achieve the required step-change in gas separation performance for coal-based gas streams. MMMs are composite structures that make use of a polymer support and a gas transport medium. MOFs are proposed as the gas transport medium because of their potentially high CO₂ uptake and the tunability of their pores. In general, MOFs will have more desirable gas transport properties than a polymer, but are very difficult to form into a free-standing and defect-free membrane film. By integrating MOFs into a polymer film, the selectivity and permeance of the film are enhanced. This makes the system more capable of dealing with a low partial pressure driving force than conventional polymers, while also retaining the processability of a polymer.

Mixed matrix membranes often suffer from poor contact between the polymer matrix and MOF crystallites. This phenomenon, known as the sieve-in-a-cage effect, can cause gas streams to bypass the MOFs without separation, thus dramatically reducing selectivity. Overcoming this problem and identifying a polymer-MOF pair with the capability to form a highly permeable and selective membrane is the focus of this project. Using an integrated materials development approach, NETL has developed new MOFs, polymers, and fabrication techniques designed to address this issue.

The NETL personnel working on this project represent expertise in polymer synthesis and characterization, MOF synthesis and characterization, molecular modelling, membrane fabrication and testing, and systems analysis. To achieve a full understanding of MOF-based MMMs, it is necessary to first understand the polymers, MOFs, polymer-MOF interactions, and the behavior of membranes. In doing so, NETL researchers expect not only to generate new, highly efficient capture devices, but also to revolutionize the understanding of this class of membranes.

technology maturity:

Bench Scale through Pilot Scale, with Actual Flue Gas

project focus:

Pre- and Post-Combustion Membrane Materials

participant:

National Energy Technology Laboratory—Research and Innovation Center

project number:

RIC Capture FY2016–2020 FWP

NETL project manager:

David Hopkinson
david.hopkinson@netl.doe.gov

principal investigator:

David Hopkinson
david.hopkinson@netl.doe.gov

partners:

Idaho National Laboratory

performance period:

10/1/15 – 9/30/16

Previously, NETL personnel developed first generation MMMs using Matrimid polymer and UiO-66 MOFs. MMMs containing different weight loadings of surface engineered UiO-66 MOF particles (12–40 wt%) exhibited improved thermal and mechanical properties, and most importantly, enhanced CO₂ separation properties over membranes (CO₂ permeability was increased by ≈200 percent and CO₂/N₂ selectivity was increased by ≈25 percent) that used UiO-66 MOFs without any surface modifications. These results confirmed the importance of mitigating interfacial defects in order to achieve increased gas separation performance. Although the CO₂ permeability of the first generation MMMs was too low to achieve the DOE programmatic goals, it was a useful proof-of-concept and stepping stone for developing higher performance polymers and MOFs.

Next generation MMMs are being designed using highly permeable polyphosphazene polymeric materials paired with SIFSIX MOFs. Both the polymer and the MOF material have fluorinated groups that enhance interaction between the materials. Recently, a portable test skid was design, constructed, and installed at the National Carbon Capture Center for evaluating the performance of these materials using actual flue gas.



Figure 1: Hollow fiber MMMs are being fabricated and tested for their long term performance characteristics in the presence of humidity and contaminants using this test setup.

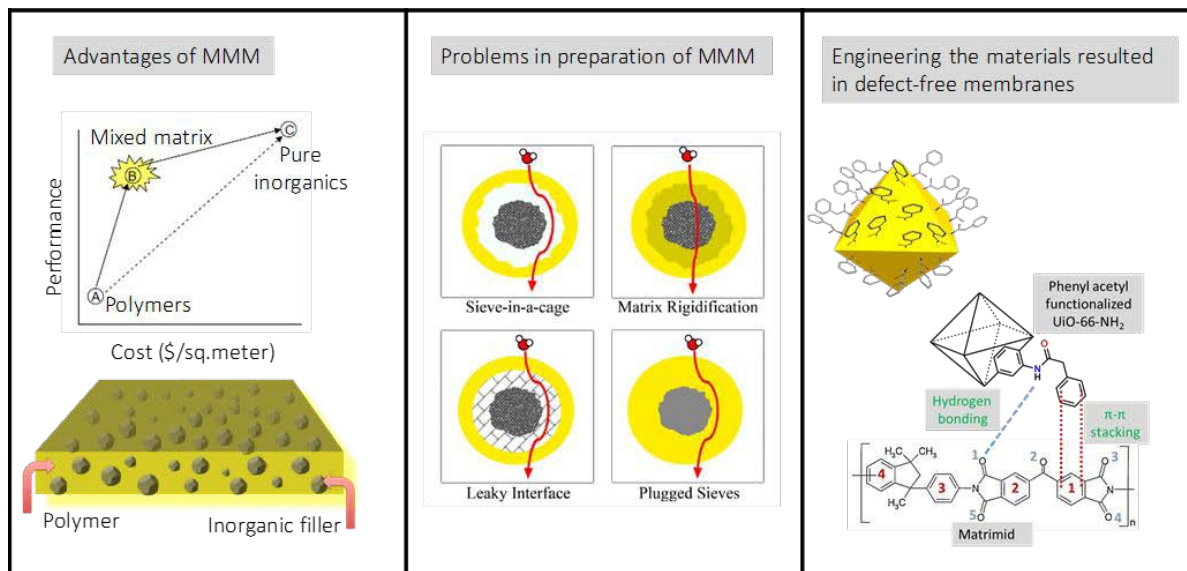

technology advantages

Membranes separate mixed gas streams according to differences in gas permeability across a membrane film. Because there is no regeneration step in a membrane-based carbon capture process, there is the potential for energy savings using this technology. Improvements in material performance can be achieved through modifications to the structure or formulation of the membrane material.

R&D challenges

Challenges for membrane development for CO₂ capture include (1) increasing the material permeability and selectivity for CO₂; (2) increasing the material performance under operating conditions such as elevated temperature or pressure; (3) increasing the resistance to contaminants including water, sulfur species, or particulates; (4) increasing the compatibility between composite membrane materials; and (5) performing with a low driving force for separation.

results to date/accomplishments

- In 2014, it was successfully proven that the surface of a UiO-66 MOF can be modified to improve the interaction between a MOF filler particle and Matrimid polymer matrix.
- In 2014, mixed matrix membrane formulations were successfully applied as a thin film coating to a hollow fiber support and tested using simulated flue gas.
- In 2015, a portable test skid for measuring membrane gas permeance was successfully designed, constructed, and installed at the National Carbon Capture Center. The test skid was operated for two weeks and was used to evaluate polyphosphazene and PIM-1 mixed matrix membranes.

next steps

- Each material will be rapidly evaluated under ideal laboratory conditions to determine suitability for continued development.
- Materials that show promise will continue for additional development under more realistic conditions, including testing with simulated, and ultimately actual flue/flue gas.
- Ongoing development efforts will focus on increasing permeability and selectivity toward CO₂; increasing the mechanical stability; and optimizing the membrane for the temperature, pressure, and gas mixture conditions that are specific to its application.

available reports/technical papers/presentations

“Fabrication of MMMs with Improved Gas Separation Properties using Externally-functionalized MOF Particles” J. Mater. Chem. A, (2015), 3, 5014-5022; S. Venna, M. Lartey, T. Li, A. Spore, S. Kumar, H. Nulwala, D. Luebke, N. Rosi, E. Albenze.

Surendar Venna, “Development of Mixed Matrix Membranes for CO₂ Separation”, North American Membrane Society Annual Meeting, Boston, MA, June 3, 2015.

Larry Hill, Marti, A., Kusuma, V., Venna, S., Nulwala, H., Hopkinson, D., “Improving the Processability and Mechanical Properties of Polymers for Use in Gas Separation Membranes,” The 2015 Gordon Research Conference on “Carbon Capture, Utilization and Storage: Defining the Frontiers,” Easton, MA, June 4, 2015.

Surendar Venna, “Mixed Matrix Membranes for Post-Combustion CO₂ Capture,” 2015 NETL CO₂ Capture Technology Meeting, Pittsburgh PA, June 23, 2015.

Anne Marti, “Metal Organic Framework (MOF) Development for CO₂ Selective Mixed Matrix Membranes,” Nanoporous Materials Seminar; Berkeley, CA 2-25-2015.

HIGH THROUGHPUT TOOLS

primary project goals

Develop advanced materials and processes that are able to reduce the energy penalty and cost of CO₂ separation over conventional technologies.

technical goals

Develop tools for rapid screening of carbon capture materials through computational approaches.

technical content

Transformational tools consist of computational methods that are designed for fast screening of a large number of structures. In the design of new types of materials, it is common to have an extremely large number of possible variations in the structure of a material. Predicting which variation will have the most desirable properties is not always obvious. Therefore, it is desirable to create and employ high-throughput computation tools able to design a very large database of hypothetical materials and yield property predictions for the database. High-throughput screening calculations are currently being carried out targeted, at predicting properties for mixed matrix membranes (MMMs). A major (additional) goal of this project is to connect atomistic-level simulations with the toolset of the Carbon Capture Simulation Initiative (CCSI), making it possible to screen new or hypothetical carbon capture materials within the context of an optimized carbon capture process.

NETL is partnering with Professor Wilmer of the University of Pittsburgh to bring such a program into maturity. Currently, researchers are carrying out high-throughput properties predictions on an existing database containing over 137,000 hypothetical porous molecular organic framework (MOF) structures. Permeation and selectivity predictions are made (at low accuracy) for all the structures. The predicted properties may be combined with experimentally determined properties for polymers in order to make a prediction for a mixed matrix membrane composed of that MOF/polymer combination. Candidates that appear promising can be selected for additional simulations for more accurate predictions. Building blocks from MOF structures showing desirable properties will be included the creation of a new database of hypothetical MOF structures that is targeted for CO₂ separation in the context of MMMs.

technology maturity:

Modeling

project focus:

High-Throughput Computational Tools

participant:

National Energy Technology Laboratory—Research and Innovation Center

project number:

RIC Capture FY2016–2020 FWP

NETL project manager:

David Hopkinson
david.hopkinson@netl.doe.gov

principal investigator:

Jan Steckel
janice.steckel@netl.doe.gov

partners:

Professor Christopher E. Wilmer
(University of Pittsburgh)

performance period:

10/1/15 – 9/30/16

technology advantages

- Computational high-throughput approaches allow for property predictions for a large number of hypothetical or real materials to determine material characteristics that lead to high performance.
- Existing materials with desirable properties can be used as building blocks for the creation of a new database of hypothetical materials targeted for mixed matrix membranes.

R&D challenges

- In the design of new types of materials, it is common to have an extremely large number of possible variations in the chemistry of a compound.
- Knowing which variation will have the most desirable properties is not always obvious without further testing.

results to date/accomplishments

Preliminary results of CH₄ adsorption in 30,000 MOFs are shown in Figure 1, which were obtained by averaging results from 500 cycles of MC production runs.

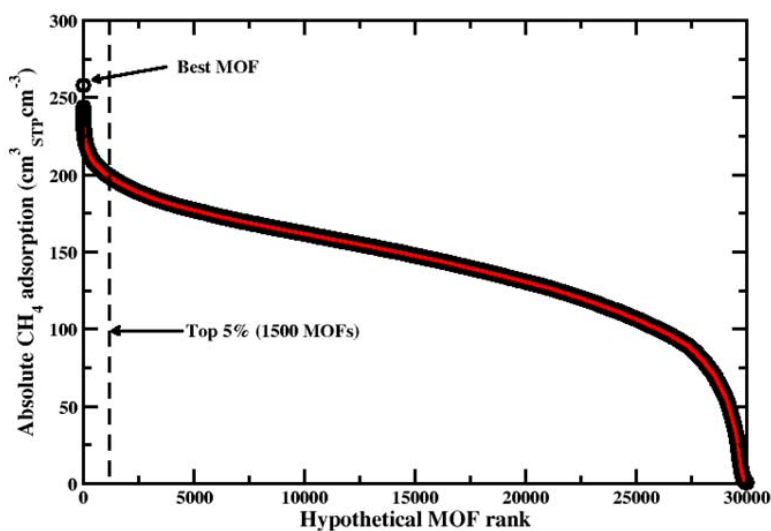

Figure 1

next steps

- Gas adsorption data prediction is nearly complete.
- Geometrical parameters for every MOF in the existing database was used to select a portion of the database for which we will predict gas diffusivity.
- Diffusivity and gas adsorption data will be combined with experimental properties of polymers in order to predict separation properties for MMMs.

CARBON CAPTURE SIMULATION FOR INDUSTRY IMPACT (CCSI²)

primary project goals

Apply the tools and models developed under the Carbon Capture Simulation Initiative (CCSI) in partnership with industry to scaleup new and innovative carbon capture technology.

technical goals

Carbon capture and storage (CCS) is critical to significantly reducing domestic and global carbon dioxide (CO₂) emissions. However, the energy and capital cost associated with carbon capture systems is prohibitive for any meaningful deployment. Today's costs of CO₂ captured from state-of-the-art carbon capture technologies must be reduced for CCS to be a viable commercial option.

Because carbon capture systems represent over 75 percent of the total cost of CCS, the need for research and development (R&D) is essential to reduce the technical and economic risks associated with CCS. To help achieve these goals, the National Energy Technology Laboratory (NETL) is funding small pilot-scale testing (equivalent of 0.5 to 5 MWe) and large pilot-scale testing (equivalent of 10 to +25 MWe). This task is meant to keep the Capture program on track to have advanced technologies available for demonstration in 2020 and ready for commercial application in 2025.

technical content

It is anticipated that the CCSI² project team will work closely with approximately two large-scale pilot projects. Carbon capture technologies selected by NETL could include solvents, sorbents, membranes, and novel technologies. Thus, CCSI² is currently built around three representative technologies (sorbents, solvents, and phase change material as an example novel concept).

The approach will include development and application of basic data submodels, process models, and device models as necessary to represent the physics of the carbon capture technologies.

technology maturity:

Practical Application of Modeling to Pilot-Scale

project focus:

Carbon Capture Simulation for Industry Impact

participant:

National Energy Technology Laboratory—Research and Innovation Center

project number:

RIC CCSI² FY2016-2020 FWP

NETL project manager:

David Miller
david.miller@netl.doe.gov

partners:

Los Alamos National Laboratory (LANL) and Pacific Northwest National Laboratory (PNNL), West Virginia University, University of Texas at Austin

performance period:

10/1//15 – 9/30/16

technology advantages

- Inform the technology developers about data requirements to enable full validation of the models so that the models can be used to predict system performance during further scaleup. In addition, the resulting models will:
 - Help improve, optimize, and integrate the capture technology during further development.
 - Help ensure the success of large-scale pilots by better understanding of dynamic behavior of the system before the test units are built and troubleshooting issues that arise during testing.

R&D challenges

- Identification and rigorous quantification of scaleup uncertainty and model enhancement to reduce such uncertainties.

results to date/accomplishments

- Validated, predictive steady-state and dynamic model of the monoethanolamine (MEA) carbon capture process. In order to develop a “gold standard” solvent model that can be used as a definitive benchmark worldwide for CO₂ capture technologies, the CCSI team completed the validation of both steady-state and dynamic models for the MEA process, which are more predictive than previous models. Validation of the dynamic model by the CCSI team not only sets an important milestone in developing “gold standard” solvent-system models, it also points to the possibility of model development and performance evaluation of solvent systems by using dynamic data that provide more information and can be collected much faster than steady-state data saving time and money spent in conducting test runs.
- Increased functionality was added to the Framework for Optimization, Quantification of Uncertainty, and Sensitivity (FOQUS). FOQUS serves as the primary computational platform enabling advanced Process Systems Engineering (PSE) capabilities to be integrated with commercial process simulation software. FOQUS now contains the following new modules:
 - The Optimization Under Uncertainty (OUU) module combines the capabilities of the DFO and the Uncertainty Quantification (UQ) modules to enable scenario-based optimization.
 - The dynamic reduced model (D-RM) module can be used to create dynamic reduced models from more detailed process models to support advanced model predictive control or enable more rapid evaluation of dynamic operating scenarios. Its incorporation into FOQUS enables D-RM creation to benefit from the parallel computing capability of the Turbine Module.
- CCSI and (General Electric) GE Cooperative Research and Development Agreement (CRADA) Project. The CRADA will enable CCSI researchers to help GE improve their models to support the scaleup of their system for testing the National Carbon Capture Center. Starting with GE’s current Aspen Plus-based model of their bench-scale system, GE and CCSI will work together to improve the performance and predictability of the process model and incorporate rigorous uncertainty quantification. Overall goals of the project include (1) providing an approach to account for error when fitting the parameters of the chemical kinetics model and process model to the experimental bench-scale data, (2) predicting uncertainty in the model for use in scaling up the aminosilicone process, and (3) providing an industry test case of the CCSI Toolset and valuable validation for a next-generation solvent for CO₂ capture. At the CCSI Industry Advisory Board Program Review Meeting, a senior leader from GE highlighted the value they have gained from the partnership.
- The CCSI released the fourth-generation of the CCSI Toolset on November 30, 2015. This is the final planned “major” release, and its capabilities are the culmination of nearly 5 years of development. The tools are available for download from <https://www.acceleratecarboncapture.org/current-product-list> for those entities with an active license. These major product bundles include:
 - CCSI Basic Data Fitting Tools, a suite of routines that fit combined thermodynamic and kinetic models from laboratory-scale data.
 - CCSI Computational Fluid Dynamics (CFD) Models, which includes validation and uncertainty quantification hierarchies for device scale models for sorbent and solvent contactors.
 - CCSI Process Models, which can be used to simulate complete carbon capture systems for using solvents, sorbents, and membranes including CO₂ compression.
 - FOQUS, which serves as the primary computational platform enabling advanced PSE capabilities to be integrated with commercial process simulation software.

- Automated Learning of Algebraic Models using Optimization (ALAMO) tool, which generate algebraic surrogate models of more complex systems to support large-scale optimization.
 - CCSI Superstructure Formulation, which uses surrogate models from ALAMO to optimize the configuration of carbon capture systems.
 - CCSI Oxy-Combustion Models, which consists of a detailed, validated boiler model and a suite of equation-based models to enable optimization of complete oxy-combustion power generation systems.
 - CCSI Advanced Process Control (APC) Framework, which enables more rapid and effective control of integrated capture systems.
 - CCSI Special Solvent Blend Models, which provide a framework for estimating the properties of blends of aqueous amines.
- Continued to generate significant industry interest in using the Toolset.
 - New licensees: 11 at the end of FY15.

next steps

The current CCSI Toolset contains models that will enable the CCSI² team to rapidly engage carbon capture technology developers who are working with solid sorbents and solvents. Depending on the specific technologies proceeding to Phase 2, some modest model development work may be required. Prior to the announcement of the Phase 2 awardees, the CCSI² team will utilize data provided by the Phase 1 awardees to develop an initial version of the models for each potential Phase 2 technology.

The CCSI² project teams will help identify data collection needs when planning and designing the two large pilot testing facilities. The teams will also assist the technology developers with their current scale project by helping with issues such as troubleshooting, design of control systems, and sensor placement.

A major focus of CCSI² will be on model validation using the large-scale pilot test information in order to help predict design and operational performance at demonstration scale and to assist with developing a robust, optimized design for demonstration scale. Thus, the CCSI² teams will assist with design modifications for moving to larger scale.

Both steady state and dynamic models will be validated so that sufficient trust in the process models can be built before advancing to the next scale. One strong focus will be on identification and rigorous quantification of scaleup uncertainty and model enhancement to reduce such uncertainties. Device-scale models will be developed and validated of the advanced capture technologies for bridging the predictive confidence between laboratory-scale, pilot-scale, and plant-scale behavior of a process. Basic data submodels necessary to represent the chemistry and material transport at the heart of most CO₂ capture processes will be developed. These submodels will capture uncertainty. UQ methodologies will be employed to help accelerate moving to the next scale with quantified technology risk using simulation-based predictions.

available reports/technical papers/presentations

Agarwal, K., Sharma, P., Ma, J., Lo, C., Gorton, I. and Yan, L. (2013). REVEAL: An Extensible Reduced Order Model Builder for Simulation and Modeling. *Computing in Science and Engineering*. 16: 44-53.

Ajayi, O., Miller, D. C., Omell, B. and Bhattacharyya, D. (2015). Simulation and Evaluation of Heat Recovery Exchangers for Solid Sorbent Carbon Capture Systems. *International Pittsburgh Coal Conference*.

Bhat, K. S., Mebane, D. S., Mahapatra, P. and Storlie, C. B. (2016). Uncertainty Quantification for Complex Multiscale Systems. *SIAM Conference for Uncertainty Quantification*. Lausanne, Switzerland.

Chen, Y., Eslick, J. C., Grossmann, I. E. and Miller, D. C. (2015). Simultaneous process optimization and heat integration based on rigorous process simulations. *Computers & Chemical Engineering*. 81: 180-199.

Chinen, A. S., Omell, B., Bhattacharyya, D., Tong, C. and Miller, D. C. (2014). Validation and Uncertainty Quantification of a High-Fidelity Model of a MEA-Based CO₂ Capture System. *AIChE Annual Meeting*.

Cozad, A., Chang, Y., Sahinidis, N. and Miller, D. C. (2011). Optimization of Carbon Capture Systems Using Surrogate Models of Simulated Processes. *AIChE Annual Meeting*.

Dowling, A. W., Biegler, L. T. and Miller, D. C. (2012). Pressure Swing Adsorption: Design and Optimization for Pre-Combustion Carbon Capture. AIChE Annual Meeting.

Eslick, J. C., Ng, B., Gao, Q., Tong, C. H., Sahinidis, N. V. and Miller, D. C. (2014). A framework for optimization and quantification of uncertainty and sensitivity for developing carbon capture systems. *Energy Procedia*. 63: 1055-1063.

Miller, D. C., Sun, X., Storlie, C. B. and Bhattacharyya, D. (2015). Using Advanced Modeling to Accelerate the Scale-Up of Carbon Capture Technologies. *Power Engineering*. 119

Tong, C., Ng, B. and Ou, J. (2014). FOQUS: A UQ Framework for Carbon Capture Process Models. AM Conference on Uncertainty Quantification.

Yu, M. and Biegler, L. T. (2015). Nonlinear Model Predictive Control of a Bubbling Fluidized Adsorber for Post-Combustion Carbon Capture. AIChE Annual Meeting.

National Energy Technology Laboratory

1450 Queen Avenue SW
Albany, OR 97321-2198
541.967.5892

420 L Street, Suite 305
Anchorage, AK 99501
907.271.3618

3610 Collins Ferry Road
P.O. Box 880
Morgantown, WV 26507-0880
304.285.4764

626 Cochran's Mill Road
Pittsburgh, PA 15236-0940
412.386.4687

13131 Dairy Ashford, Suite 225
Sugar Land, TX 77478
281.494.2516

Customer Service
1.800.553.7681

Website
www.netl.doe.gov

DOE/NETL Carbon Capture Program R&D
Compendium of Carbon Capture Technology
July 2015



U.S. DEPARTMENT OF
ENERGY

